

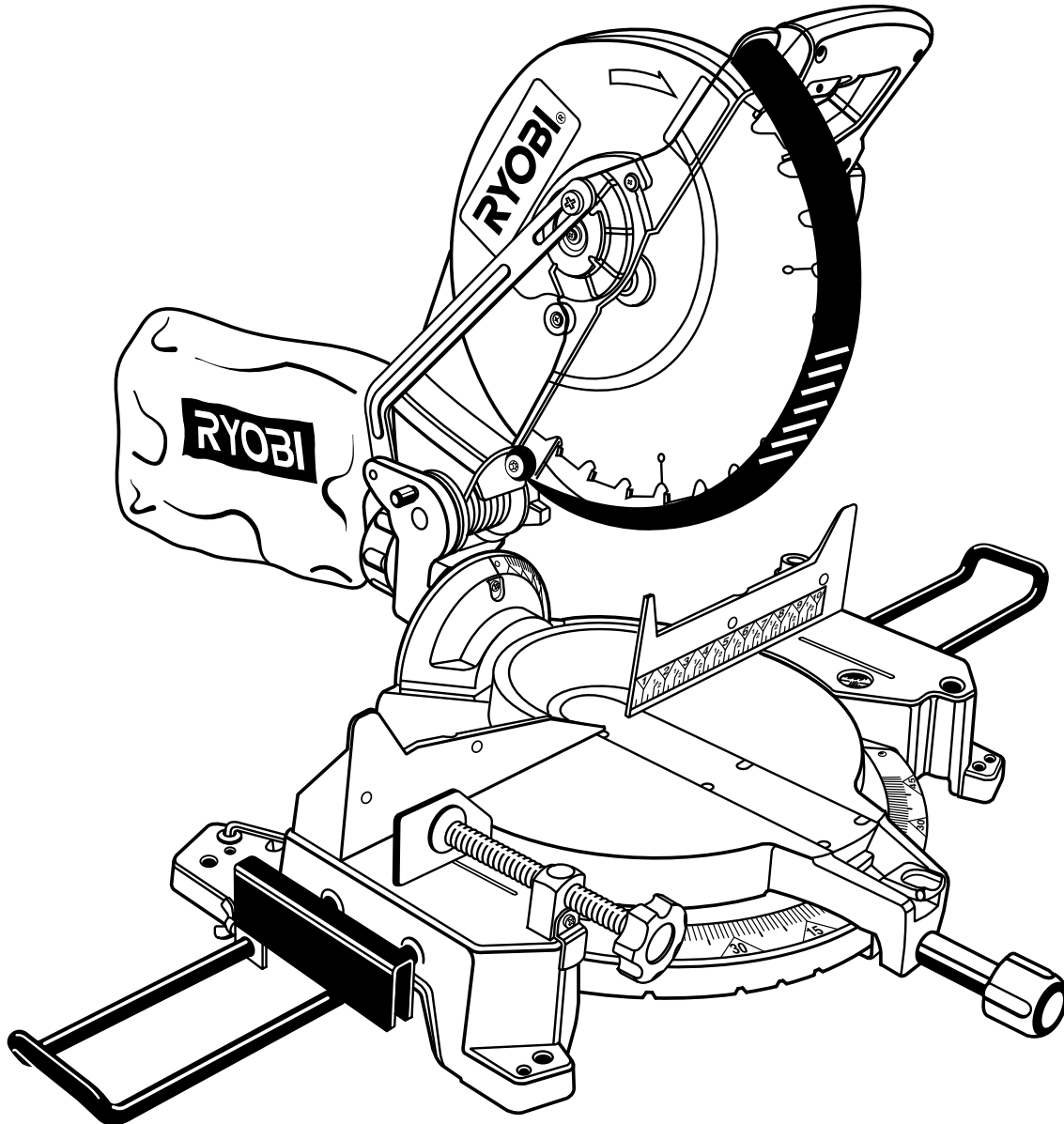

# OPERATOR'S MANUAL

## 12 in. (305 mm) Compound Miter Saw Model TS1551 - Double Insulated



Your new Miter Saw has been engineered and manufactured to Ryobi's high standards for dependability, ease of operation, and operator safety. Properly cared for, it will give you years of rugged, trouble-free performance.



**WARNING:** To reduce the risk of injury, the user must read and understand the operator's manual before using this product.

Thank you for buying a Ryobi tool.

**SAVE THIS MANUAL FOR FUTURE REFERENCE**

# TABLE OF CONTENTS

■ Introduction and Product Specifications .....	2
■ Rules for Safe Operation .....	3-6
■ Glossary of Terms .....	6
■ Unpacking and Tools Needed .....	7
■ Loose Parts .....	8
■ Features .....	9-11
■ Assembly .....	12-15
■ Adjustments .....	15-19
■ Operation .....	19-26
■ Laser Guide .....	27-28
■ Maintenance .....	29
■ Parts Ordering/Service .....	30

## INTRODUCTION

Your saw has many features for making cutting operations more pleasant and enjoyable. Safety, performance, and dependability have been given top priority in the design of this saw making it easy to maintain and operate.

### **WARNING:**

Do not attempt to use the tool until you have read thoroughly and understand completely the operator's manual. Pay close attention to the safety rules, including Dangers, Warnings, and Cautions. If you use this tool properly and only for what it is intended, you will enjoy years of safe, reliable service.

## PRODUCT SPECIFICATIONS

Blade Arbor	1 in. (25.4 mm)
Blade Diameter	12 in. (305 mm)
Rating	120 volts, 60Hz, AC Only
No Load Speed	3600 RPM
Input	15 Amperes
Net Weight	41 lbs. (18.6 kg.)

### **WARNING:**



The operation of any power tool can result in foreign objects being thrown into your eyes, which can result in severe eye damage. Before beginning tool operation, always wear safety goggles or safety glasses with side shields and a full face shield when needed. We recommend Wide Vision Safety Mask for use over eyeglasses or standard safety glasses with side shields. Always wear eye protection which is marked to comply with ANSI Z87.1.



**Look for this symbol to point out important safety precautions. It means attention!!! Your safety is involved.**

# RULES FOR SAFE OPERATION

The purpose of safety symbols is to attract your attention to possible dangers. The safety symbols, and the explanations with them, deserve your careful attention and understanding. The safety warnings do not by themselves eliminate any danger. The instructions or warnings they give are not substitutes for proper accident prevention measures.

## Symbol Meaning



**DANGER:** Indicates an imminently hazardous situation which, if not avoided, will result in death or serious injury.



**WARNING:** Indicates a potentially hazardous situation which, if not avoided, could result in death or serious injury.



**CAUTION:** Indicates a potentially hazardous situation which, if not avoided, may result in minor or moderate injury. It may also be used to alert against unsafe practices that may cause property damage.

**NOTE:** Advises you of information or instructions vital to the operation or maintenance of the equipment.

## SAFETY AND INTERNATIONAL SYMBOLS

This operator's manual describes safety and international symbols and pictographs that may appear on this product. Read the operator's manual for complete safety, assembly, operating and maintenance, and repair information.

### SYMBOL



### MEANING

- Do not expose to rain or use in damp locations.



### NO HANDS SYMBOL

- Failure to keep your hands away from the blade will result in serious personal injury.

## DOUBLE INSULATION

Double insulation is a concept in safety, in electric power tools, which eliminates the need for the usual three-wire ground power cord. All exposed metal parts are isolated from the internal metal motor components with protecting insulation. Double insulated tools do not need to be grounded.



### WARNING:

The double insulated system is intended to protect the user from shock resulting from a break in the tool's internal insulation. Observe all normal safety precautions related to avoiding electrical shock.

## IMPORTANT

Servicing of a tool with double insulation requires extreme care and knowledge of the system and should be performed only by a qualified service technician. For service we suggest you return the tool to your nearest **RYOBI AUTHORIZED SERVICE CENTER** for repair. When servicing use only identical Ryobi replacement parts.



### WARNING:

Do not attempt to operate this tool until you have read thoroughly and understand completely all instructions, safety rules, etc., contained in this manual. Failure to comply can result in accidents involving fire, electric shock, or serious personal injury. Save operator's manual and review frequently for continuing safe operation, and instructing others who may use this tool.

# RULES FOR SAFE OPERATION

Safe operation of this power tool requires that you read and understand this operator's manual and all labels affixed to the tool. Safety is a combination of common sense, staying alert, and knowing how your miter saw works.

## READ ALL INSTRUCTIONS

- **KNOW YOUR POWER TOOL.** Read the operator's manual carefully. Learn the saw's applications and limitations as well as the specific potential hazards related to this tool.
- **GUARD AGAINST ELECTRICAL SHOCK** by preventing body contact with grounded surfaces such as pipes, radiators, ranges, refrigerator enclosures.
- **KEEP GUARDS IN PLACE** and in good working order.
- **REMOVE WRENCHES AND ADJUSTING KEYS.** Get in the habit - before turning on tool - that hex keys and adjusting wrenches are removed from tool.
- **KEEP THE WORK AREA CLEAN.** Cluttered work areas and work benches invite accidents. **DO NOT** leave tools or pieces of wood on the saw while it is in operation.
- **DO NOT USE IN DANGEROUS ENVIRONMENTS.** Do not use power tools near gasoline or other flammable liquids, in damp or wet locations, or expose them to rain. Keep the work area well lit.
- **KEEP CHILDREN AND VISITORS AWAY.** All visitors should wear safety glasses and be kept a safe distance from work area. Do not let visitors contact tool or extension cord while operating.
- **MAKE WORKSHOP CHILDPROOF** with padlocks and master switches or by removing starter keys.
- **DO NOT FORCE THE TOOL** it will do the job better and safer at the rate for which it was designed.
- **USE THE RIGHT TOOL FOR THE JOB.** Do not force the tool or attachment to do a job it was not designed for. Use it only the way it was intended.
- **USE THE PROPER EXTENSION CORD.** Make sure your extension cord is in good condition. Use only a cord heavy enough to carry the current your product will draw. An undersized cord will cause a drop in line voltage resulting in loss of power and overheating. A wire gage size (A.W.G.) of at least **14** is recommended for an extension cord 25 feet or less in length. If in doubt, use the next heavier gage. The smaller the gage number, the heavier the cord.
- **INSPECT TOOL CORDS AND EXTENSION CORDS PERIODICALLY** and, if damaged, have repaired at your nearest authorized service center. Stay constantly aware of cord location and keep it well away from the moving blade.
- **DRESS PROPERLY.** Do not wear loose clothing, gloves, neckties, rings, bracelets, or other jewelry that can get caught and draw you into moving parts. Nonslip footwear is recommended. Also wear protective hair covering to contain long hair.
- **ALWAYS WEAR SAFETY GLASSES WITH SIDE SHIELDS.** Everyday eyeglasses have only impact-resistant lenses; they are **NOT** safety glasses.
- **WEAR A DUST MASK** to keep from inhaling fine particles.
- **PROTECT YOUR HEARING.** Wear hearing protection during extended periods of operation.
- **SECURE WORK.** Use clamps or a vise to hold work when practical. It's safer than using your hand and frees both hands to operate tool.
- **DO NOT OVERREACH.** Keep proper footing and balance at all times.
- **MAINTAIN TOOLS WITH CARE.** Keep tools sharp and clean for better and safer performance. Follow instructions for lubricating and changing accessories.
- **DISCONNECT ALL TOOLS.** When not in use, before servicing, or when changing attachments, all tools should be disconnected.
- **AVOID ACCIDENTAL STARTING.** Be sure switch is off when plugging in any tool.
- **USE RECOMMENDED ACCESSORIES.** Consult the operator's manual for recommended accessories. The use of improper accessories may cause risk of injury.
- **NEVER STAND ON TOOL.** Serious injury could occur if the tool is tipped or if the blade is unintentionally contacted.
- **CHECK DAMAGED PARTS.** Before using the tool, a guard or other part that is damaged should be carefully checked to determine that it will operate properly and perform its intended function. Check for alignment of moving parts, binding of moving parts, breakage of parts, mounting and any other conditions that may affect its operation. A guard or other part that is damaged must be properly repaired or replaced by an authorized service center to avoid risk of personal injury.
- **NEVER LEAVE TOOL RUNNING UNATTENDED, TURN THE POWER OFF.** Do not leave tool until it comes to a complete stop.
- **FIRMLY CLAMP OR BOLT** your miter saw to a workbench or table at approximately hip height.
- **USE ONLY CORRECT BLADES.** Use the right blade size, style and cutting speed for material and type of cut. Do not use blades with incorrect size holes. Never use blade washers or blade bolts that are defective or incorrect. The maximum blade capacity of your saw is 12 in.
- **KEEP BLADES CLEAN, SHARP, AND WITH SUFFICIENT SET.** Sharp blades minimize stalling and kick-back.
- **DO NOT REMOVE THE SAW'S BLADE GUARDS.** Never operate the saw with any guard or cover removed. Make sure all guards are operating properly before each use.
- **KEEP HANDS AWAY FROM CUTTING AREA.** Do not reach underneath work or in blade cutting path with hands and fingers for any reason. Always turn power off.

# RULES FOR SAFE OPERATION

- **BLADE COASTS AFTER BEING TURNED OFF.**
- **DO NOT ABUSE CORD.** Never yank cord to disconnect it from receptacle. Keep cord from heat, oil, and sharp edges.
- **USE ONLY OUTDOOR EXTENSION CORDS.** Use only extension cords with the marking "Acceptable for use with outdoor appliances; store cords indoors while not in use". Use extension cords with an electrical rating not less than the saw's rating. Always disconnect the extension cord from the outlet before disconnecting the product from the extension cord.
- **DO NOT USE TOOL IF SWITCH DOES NOT TURN IT ON AND OFF.** Have defective switches replaced by an authorized service center.
- **KEEP TOOL DRY, CLEAN, AND FREE FROM OIL AND GREASE.** Always use a clean cloth when cleaning. Never use brake fluids, gasoline, petroleum-based products, or any solvents to clean tool.
- **ALWAYS SUPPORT LONG WORKPIECES** while cutting to minimize risk of blade pinching and kickback. Saw may slip, walk or slide while cutting long or heavy boards.
- **BEFORE MAKING A CUT,** be sure all adjustments are secure.
- **BE SURE BLADE PATH IS FREE OF NAILS.** Inspect for and remove all nails from lumber before cutting.
- **NEVER TOUCH BLADE** or other moving parts during use for any reason.
- **BE SURE THE BLADE CLEARS THE WORKPIECE.** Never start the saw with the blade touching the workpiece. Allow motor to come up to full speed before starting cut.
- **MAKE SURE MITER TABLE AND SAW ARM (BEVEL FUNCTION) ARE LOCKED IN POSITION BEFORE OPERATING YOUR SAW.** Lock the miter table by securely tightening the miter lock handle. Lock the saw arm (bevel function) by securely tightening the bevel lock knob.
- **NEVER USE A LENGTH STOP ON THE FREE SCRAP END OF A CLAMPED WORKPIECE. NEVER** hold onto or bind the free scrap end of the workpiece in any operation. If a work clamp and length stop are used together, they must both be installed on the same side of the saw table to prevent the saw from catching the loose end and kicking up.
- **NEVER** cut more than one piece at a time. **DO NOT STACK** more than one workpiece on the saw table at a time.
- **NEVER PERFORM ANY OPERATION FREEHAND.** Always place the workpiece to be cut on the miter table and position it firmly against the fence as a backstop. Always use the fence.
- **NEVER** reach behind, under, or within three inches of the blade and its cutting path with your hands and fingers for any reason.
- **NEVER** hand hold a workpiece that is too small to be clamped. Keep hands clear of the no hands zone.
- **NEVER** reach to pick up a workpiece, a piece of scrap, or anything else that is in or near the cutting path of the blade.
- **AVOID AWKWARD OPERATIONS AND HAND POSITIONS** where a sudden slip could cause your hand to move into the blade. **ALWAYS** make sure you have good balance. **NEVER** operate your miter saw on the floor or in a crouched position.
- **NEVER** stand or have any part of your body in line with the path of the saw blade.
- **ALWAYS** release the power switch and allow the saw blade to stop rotating before raising it out of the workpiece.
- **DO NOT TURN THE MOTOR SWITCH ON AND OFF RAPIDLY.** This could cause the saw blade to loosen and could create a hazard. Should this ever occur, stand clear and allow the saw blade to come to a complete stop. Disconnect your saw from the power supply and securely retighten the blade bolt.
- **REPLACEMENT PARTS.** All repairs, whether electrical or mechanical, should be made at your nearest authorized service center.
- **WHEN SERVICING,** use only identical Ryobi replacement parts. Use of any other parts may create a hazard or cause product damage.
- **NEVER USE THIS TOOL IN AN EXPLOSIVE ATMOSPHERE.** Normal sparking of the motor could ignite fumes.
- **POLARIZED PLUGS.** To reduce the risk of electric shock, this tool has a polarized plug (one blade is wider than the other). This plug will fit in a polarized outlet only one way. If the plug does not fit fully in the outlet, reverse the plug. If it still does not fit, contact a qualified electrician to install the proper outlet. Do not change the plug in any way.
- **IF ANY PART OF THIS MITER SAW IS MISSING** or should break, bend, or fail in any way, or should any electrical component fail to perform properly, shut off the power switch, remove the miter saw plug from the power source and have damaged, missing, or failed parts replaced before resuming operation.
- **DO NOT OPERATE THIS TOOL WHILE UNDER THE INFLUENCE OF DRUGS, ALCOHOL, OR ANY MEDICATION.**
- **ALWAYS STAY ALERT!** Do not allow familiarity (gained from frequent use of your saw) to cause a careless mistake. **ALWAYS REMEMBER** that a careless fraction on a second is sufficient to inflict serious injury.

# RULES FOR SAFE OPERATION

- **STAY ALERT AND EXERCISE CONTROL.** Watch what you are doing and use common sense. **Do not operate tool when you are tired. Do not rush.**
- **MAKE SURE THE WORK AREA HAS AMPLE LIGHTING** to see the work and that no obstructions will interfere with safe operation **BEFORE** performing any work using your saw.
- **ALWAYS TURN OFF THE SAW** before disconnecting it to avoid accidental starting when reconnecting to power supply. **NEVER** leave the saw unattended while connected to a power source.
- **ALWAYS** carry the saw only by the carrying handle.
- **AVOID** direct eye exposure when using the laser guide.
- **SAVE THESE INSTRUCTIONS.** Refer to them frequently and use them to instruct other users. If you loan someone this tool, loan them these instructions also.

## **WARNING:**

Some dust created by power sanding, sawing, grinding, drilling, and other construction activities contains chemicals known to cause cancer, birth defects or other reproductive harm. Some examples of these chemicals are:

- lead from lead-based paints,
- crystalline silica from bricks and cement and other masonry products, and
- arsenic and chromium from chemically-treated lumber.

Your risk from these exposures varies, depending on how often you do this type of work. To reduce your exposure to these chemicals, work in a well ventilated area and work with approved safety equipment, such as those dust masks that are specially designed to filter out microscopic particles.

## SAVE THESE INSTRUCTIONS

# GLOSSARY OF TERMS FOR WOODWORKING

### **Arbor**

The shaft on which a blade or cutting tool is mounted.

### **Bevel Cut**

A cutting operation made with the blade at any angle other than 90° to the miter table.

### **Compound Miter Cut**

A compound miter cut is a cut made using a miter angle and a bevel angle at the same time.

### **Crosscut**

A cutting or shaping operation made across the grain of the workpiece.

### **Freehand**

Performing a cut without using a fence, vise, fixture, work clamp, or other proper device to keep the workpiece from twisting or moving during the cut.

### **Gum**

A sticky, sap based residue from wood products.

### **Miter Cut**

A cutting operation made with the blade at any angle other than 90° to the fence.

### **No Hands Zone**

Area between the marked lines on the left and right side of the miter table base. This zone is identified by no hands zone labels placed inside the marked lines on the miter table base.

### **Resin**

A sticky, sap base substance that has hardened.

### **Revolutions Per Minute (RPM)**

The number of turns completed by a spinning object in one minute.

### **Saw Blade Path**

The area over, under, behind, or in front of the blade. As it applies to the workpiece, that area which will be, or has been, cut by the blade.

### **Set**

The distance that the tip of the saw blade tooth is bent (or set) outward from the face of the blade.

### **Through Sawing**

Any cutting operation where the blade extends completely through the thickness of the workpiece.

### **Throw-Back**

Throwing of a workpiece in a manner similar to a kickback. Usually associated with a cause other than the kerf closing, such as a workpiece not being against the fence, being dropped into the blade, or being placed inadvertently in contact with the blade.

### **Workpiece**

The item on which the cutting operation is being done. The surfaces of a workpiece are commonly referred to as faces, ends, and edges.

### **Zero Clearance Throat Plate**

A plastic throat plate inserted in the miter table that allows for blade clearance. When you make your first cut with your compound miter saw, the saw blade cuts a slot through the throat plate the exact width of the blade. This provides for a zero clearance kerf that minimizes workpiece tear-out.

# UNPACKING

Your Compound Miter Saw has been shipped completely assembled except for the blade, miter lock handle, dust guide or dust bag, table extensions, work clamp, and stop block.

- Remove all loose parts from the carton. Separate and check with the list of loose parts. See Figure 1.
- Remove the packing materials from around your saw.
- Carefully lift saw from the carton by the carrying handle and place it on a level work surface. Although small, this saw is heavy. To avoid back injury, get help when needed.
- Do not discard the packing materials until you have carefully inspected the saw, identified all loose parts, and satisfactorily operated your new saw.
- Your saw has been shipped with the saw arm secured in the down position. To release the saw arm, push down on top of saw arm and cut the tie-wrap.

- Lift the saw arm by the handle. Hand pressure should remain on the saw arm to prevent sudden rise upon release of the tie wrap.
- Examine all parts to make sure no breakage or damage has occurred during shipping.

If any parts are missing, do not attempt to assemble the miter saw, plug in the power cord, or turn the switch on until the missing parts are obtained and are installed correctly. Call 1-800-525-2579 for assistance if any parts are missing or damaged.

## **WARNING:**

If any parts are missing, do not operate this tool until the missing parts are replaced. Failure to do so could result in possible serious personal injury.

# TOOLS NEEDED

The following tools (not included) are needed for checking adjustments of your saw or for installing the blade:

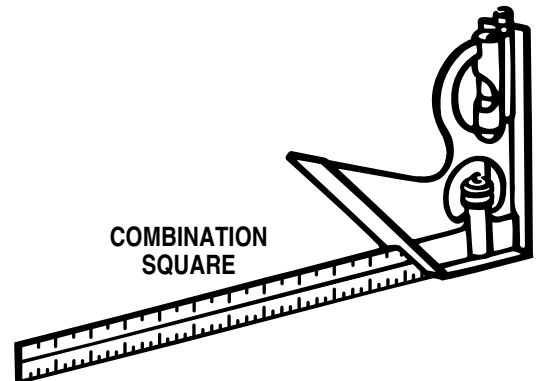
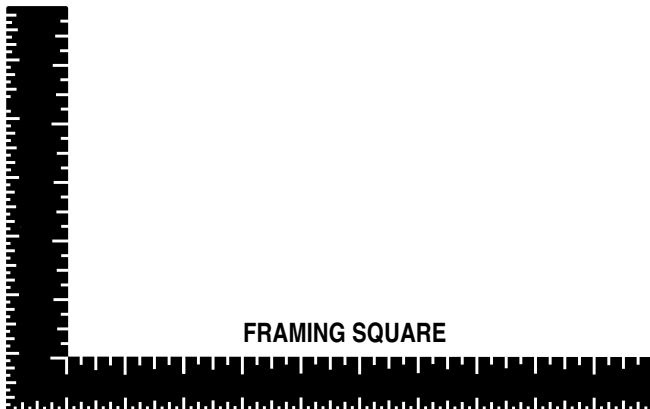

# LOOSE PARTS LIST

The following items are included with your Compound Miter Saw:

- 12 in. (305 mm) Saw Blade
- Miter Lock Handle
- Dust Bag
- Dust Guide
- Stop Block
- Small Wing Screw
- Clamp Brackets (2)
- Clamp Bracket Screws (2)
- Table Extensions (2)
- Work Clamp
- Blade Wrench
- Hex Key
- Laser Guide
- Hex Key Bolt
- Operator's Manual
- Warranty Registration Card

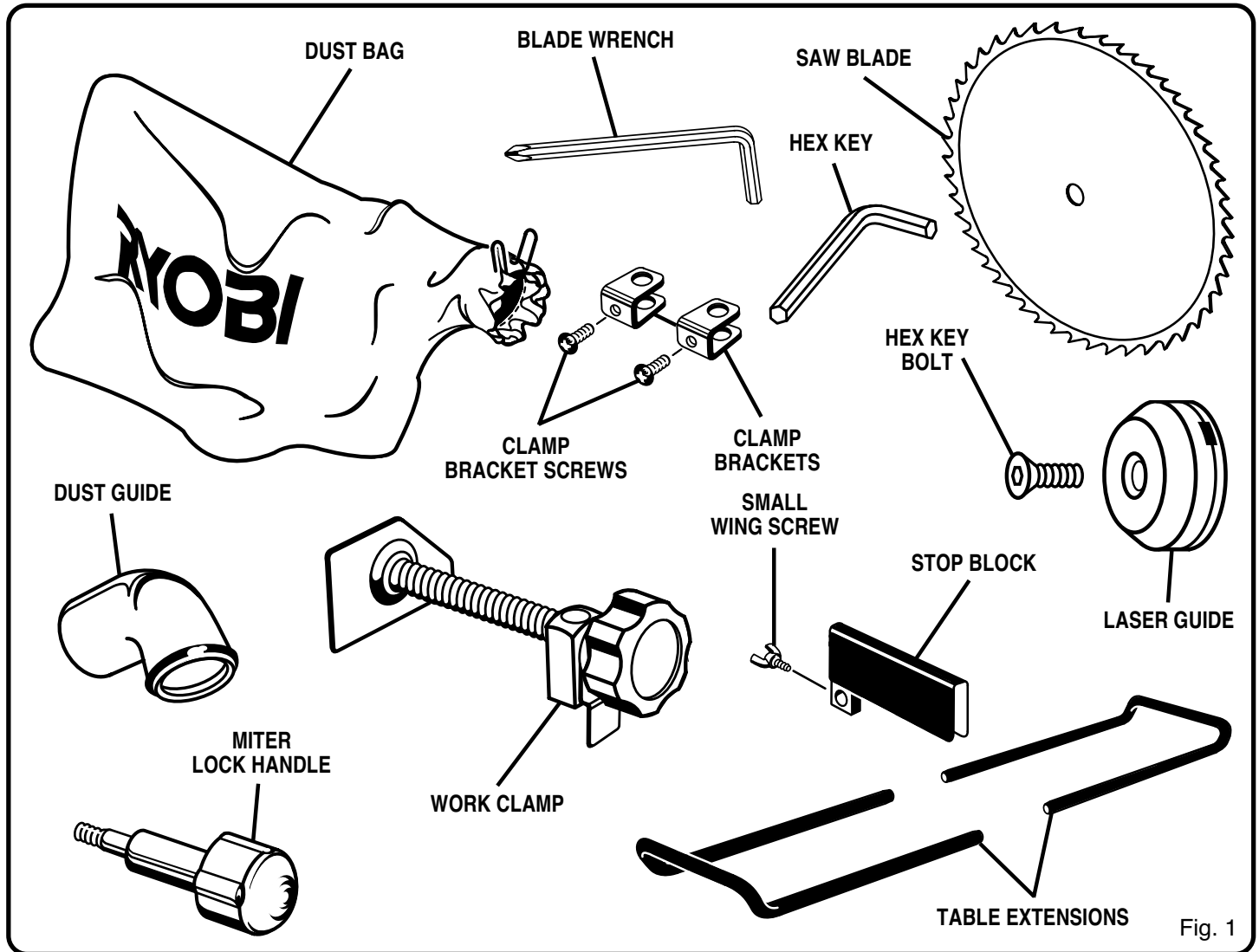

**WARNING:** The use of attachments or accessories not listed might be hazardous and could cause serious personal injury.



# FEATURES

## KNOW YOUR COMPOUND MITER SAW

See Figure 2.

Before attempting to use your saw, familiarize yourself with all operating Features and Rules for Safe Operation.

### **⚠ WARNING:**

Do not allow familiarity with your saw to make you careless. Remember that a careless fraction of a second is sufficient to inflict severe injury.

## 15 AMP MOTOR

Your saw has a powerful 15 amp motor with sufficient power to handle tough cutting jobs. It is made with all ball bearings.

## 12 in. BLADE

A 12 in. (305 mm) saw blade is included with your compound miter saw. It is fine for most wood cutting operations, but for fine joinery cuts or cutting plastic, use one of the accessory blades available from your nearest dealer.

## CUTTING CAPACITIES

**When the miter angle (miter table) is set at 0°:**

Maximum dimensional sizes: 4 in. x 4 in.

2 1/2 in. x 7 7/8 in.

**When the miter angle (miter table) is set at 45°:**

Maximum dimensional size: 2 1/2 in. x 5 1/2 in.

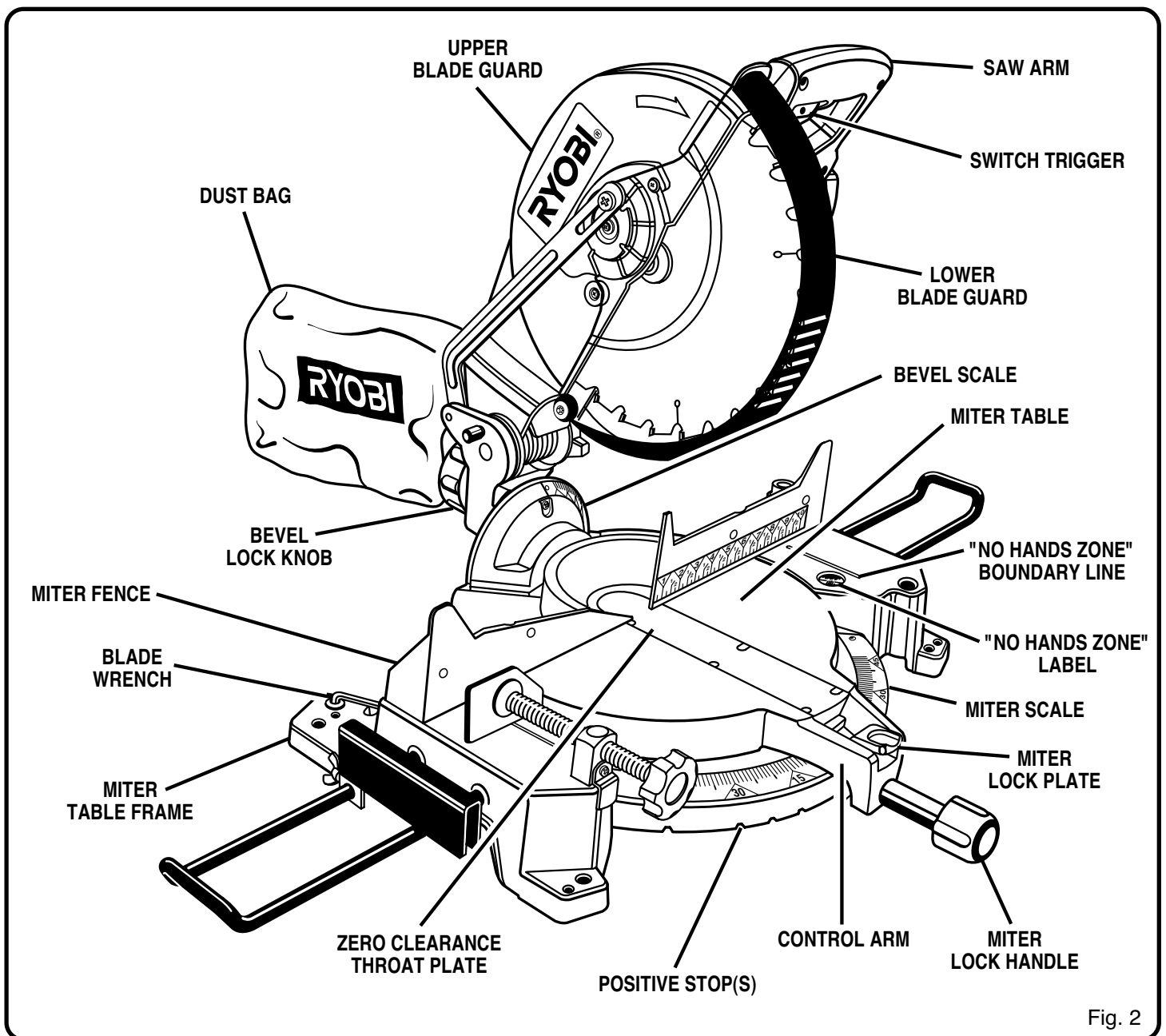

Fig. 2

# FEATURES

## BLADE WRENCH / STORAGE AREA

See Figure 2.

A blade wrench is packed with your saw. One end of the wrench is a phillips screwdriver and the other end is a 1/4 in. (6.4 mm) hex key. Use the hex key end when installing or removing blade and the phillips end when removing or loosening screws. A storage area for the blade wrench is located behind the fence.

## CARRYING HANDLE

See Figure 3.

For convenience when carrying or transporting your miter saw from one place to another, a carrying handle has been provided on top of the saw arm as shown in figure 3. To transport, turn off and unplug your saw, then lower the saw arm and lock it in the down position. Lock saw arm by depressing the lock pin.

## MITER LOCK HANDLE

See Figure 3.

The miter lock handle securely locks your saw at desired miter angles.

## SPINDLE LOCK BUTTON

See Figure 4.

A spindle lock button has been provided for locking the spindle which keeps the blade in your saw from rotating. Depress and hold the lock button while installing, changing, or removing blade only.

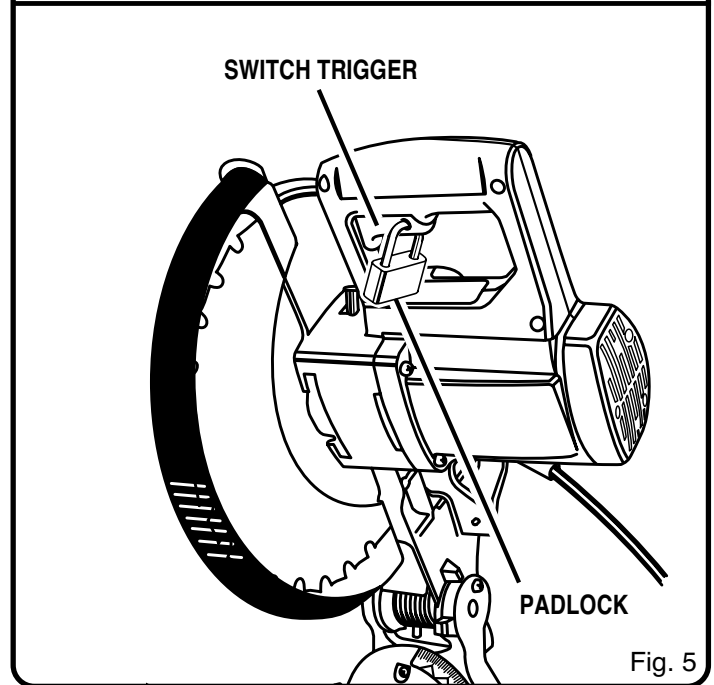
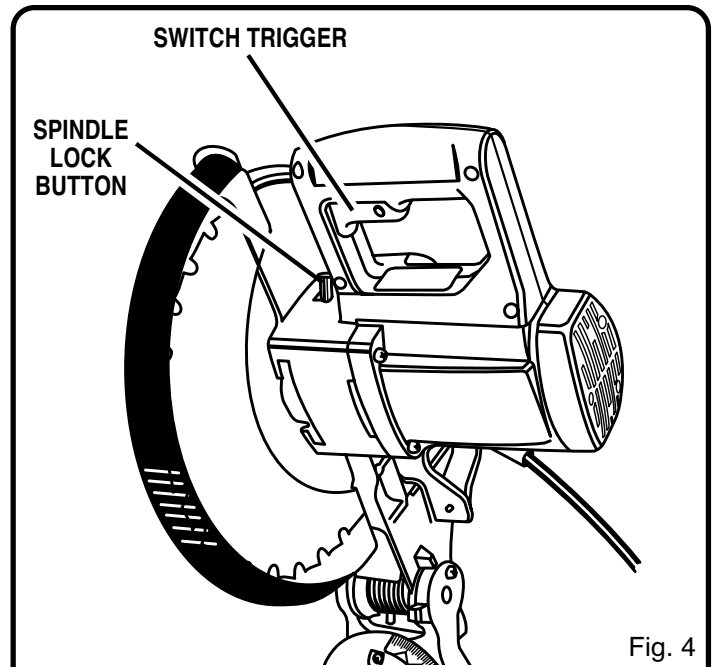
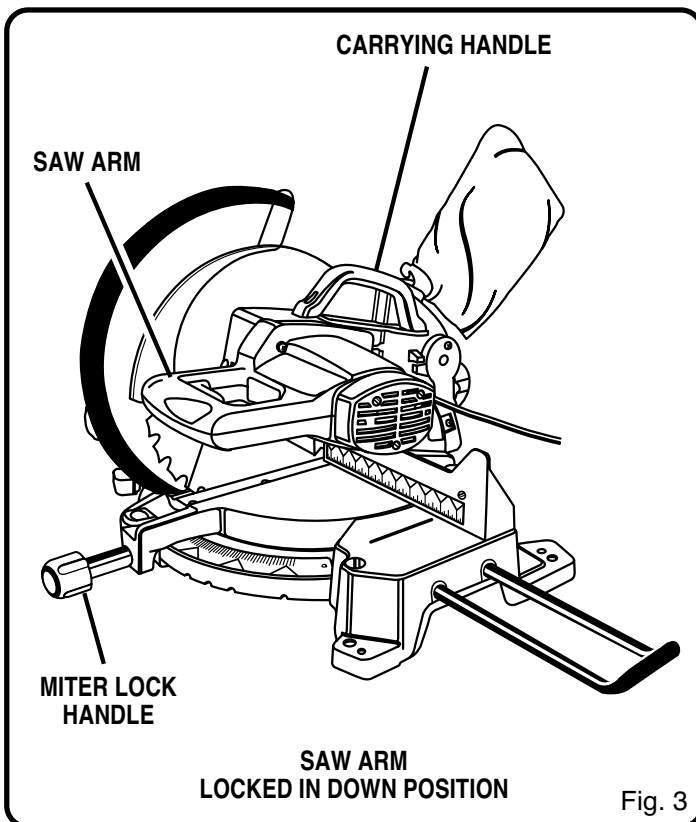

## TRIGGER LOCK

See Figure 5.

To prevent unauthorized use of your compound miter saw, we suggest that you disconnect it from the power supply and lock the switch in the off position. To lock the switch, install a padlock (not included) through the hole in the switch trigger. A lock with a long shackle up to 19/64 in. (7 mm) diameter may be used. When the lock is installed and locked, the switch is inoperable. Store the padlock key in another location.

# FEATURES

## POSITIVE STOPS ON MITER TABLE

Positive stops have been provided at 0°, 15°, 22-1/2°, 30°, and 45°. The 22-1/2° and 45° positive stops have been provided on both the left and right side of the miter table.

## BEVEL LOCK KNOB

The bevel lock knob securely locks your compound miter saw at desired bevel angles. Positive stop adjustment screws have been provided on each side of the saw arm. These adjustment screws are for making fine adjustments at 0° and 45°.

## ELECTRIC BRAKE

An electric brake has been provided to quickly stop blade rotation after the switch is released.

## MITER FENCE

The miter fence on your compound miter saw has been provided to hold your workpiece securely against when making all cuts; the left side is also larger providing additional support.

## SELF-RETRACTING LOWER BLADE GUARD

The lower blade guard is made of shock-resistant, see-through plastic that provides protection from each side of the blade. It retracts over the upper blade guard as the saw is lowered into the workpiece.

### ⚠️ WARNING:

To avoid serious personal injury, always assure saw is fully supported and securely attached to a level work surface.

### ⚠️ WARNING:

Do not attempt to modify this tool or create accessories not recommended for use with this tool. Any such alteration or modification is misuse and could result in a hazardous condition leading to possible serious personal injury.

## MOUNTING HOLES

See Figure 6.

Your compound miter saw should be mounted to a firm supporting surface such as a workbench. Four bolt holes have been provided in the saw base for this purpose. Each of the four mounting holes should be bolted securely using 3/8 in. (10 mm) machine bolts, lock washers, and hex nuts (not included). Bolts should be of sufficient length to accommodate the saw base, lock washers, hex nuts, and the thickness of the workbench. Tighten all four bolts securely.

The hole pattern is for an 18 in. x 24 in. (457 mm x 610 mm) workbench. Carefully check the workbench after mounting to make sure that no movement can occur during use. If any tipping, sliding, or walking is noted, secure the workbench to the floor before operating.

## ELECTRICAL CONNECTION

Your saw has a precision built electric motor. It should be connected to a **power supply that is 120 volts, 60Hz, AC only (normal household current)**. Do not operate this tool on direct current (DC). A substantial voltage drop will cause a loss of power and the motor will overheat. If your tool does not operate when plugged into an outlet, double-check the power supply.

### ⚠️ WARNING:

The operation of any saw can result in foreign objects being thrown into your eyes, which can result in severe eye damage. Before starting power tool operation, always wear safety goggles or safety glasses with side shields and a full face shield when needed. We recommend wide vision safety mask for use over eyeglasses or standard safety glasses with side shields.

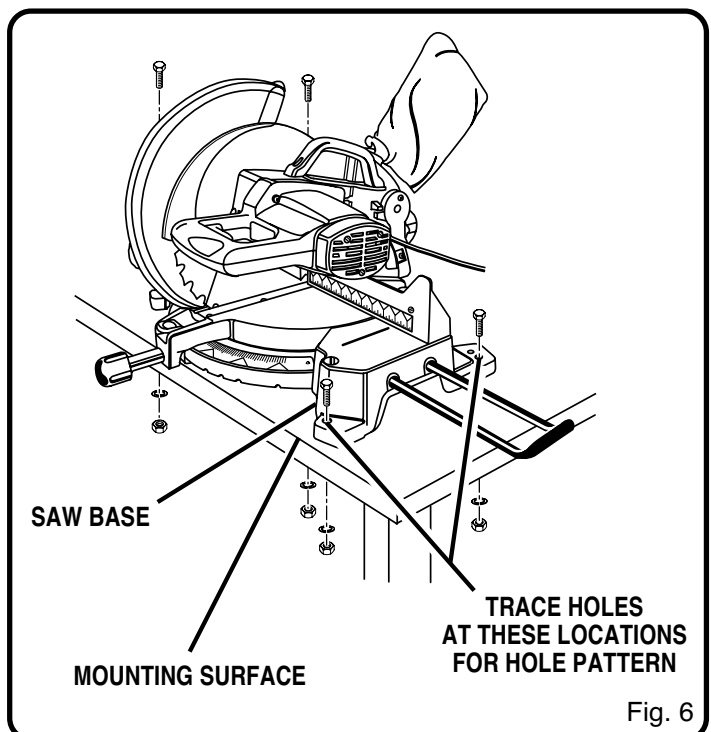

Fig. 6

# ASSEMBLY

## **⚠ WARNING:**

To prevent accidental starting that could cause possible serious personal injury, assemble all parts, make sure all adjustments are complete, and make sure all fasteners are secure before connecting saw to power supply. Saw should never be connected to power supply when you are assembling parts, making adjustments, installing or removing blades, or when not in use.

## **MITER LOCK HANDLE**

See Figure 7.

To install the miter lock handle, place the threaded stud on the end of the miter lock handle into the threaded hole in the control arm under miter table. Turn clockwise to tighten.

## **DUST GUIDE**

See Figure 8.

To install the dust guide, place the end over the exhaust port in the upper blade guard. Turn the guide so that the open end is facing down.

## **DUST BAG**

See Figure 9.

A dust bag is provided for use on your miter saw. It fits over the exhaust port on the upper blade guard. To install it, remove dust guide from exhaust port. Then, squeeze the two metal clips to open the mouth of the bag and slide it on the exhaust port. Release the clips. The metal ring in the bag should lock in between the grooves on the exhaust port. To remove the dust bag for emptying, simply reverse the above procedure.

## **WORK CLAMP**

See Figure 10.

The work clamp provides greater control by clamping the workpiece to the fence or the saw table. It also prevents the workpiece from creeping toward the saw blade. This is very helpful when cutting compound miters.

Depending on the cutting operation and the size of the workpiece, it may be necessary to use a C-clamp instead of the work clamp to secure the workpiece prior to making the cut.

## **⚠ WARNING:**

In some operations, the work clamp assembly may interfere with the operation of the blade guard assembly. Always make sure there is no interference with the blade guard prior to beginning any cutting operation to reduce the risk of serious personal injury.

Follow these directions to install the work clamp:

- Place the shaft of the work clamp in either hole on the saw table base.
- Rotate the knob on the work clamp to move it in or out as needed.

## **⚠ WARNING:**

When using any clamp with the stop block, install the clamp on the same side as the stop block. This will eliminate the possibility of trapping the workpiece, resulting in the saw blade and workpiece kicking up. Failure to heed this warning can result in serious personal injury.

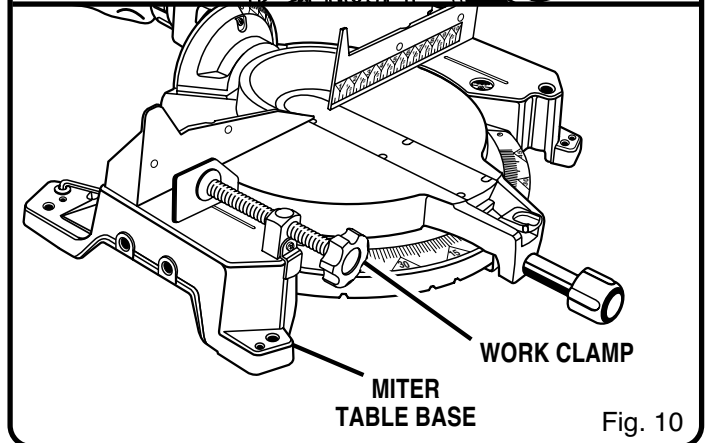
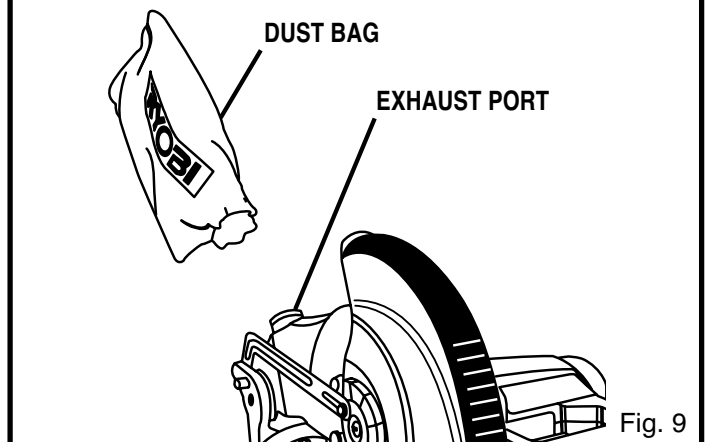
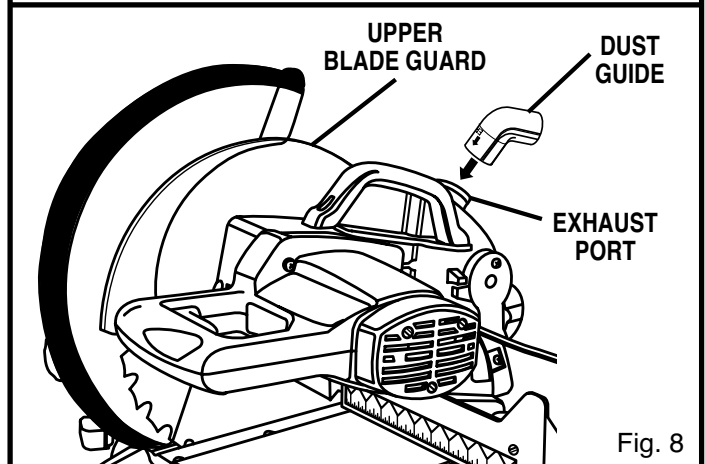
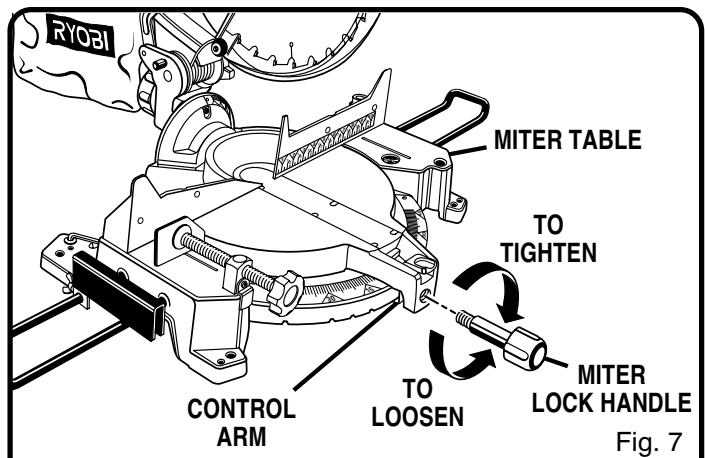

# ASSEMBLY

## TABLE EXTENSIONS

See Figures 11, 12, and 13.

If you plan to use the stop block, slide the stop block on the back arm of the desired table extension first.

To install table extensions, insert the ends of extensions into the holes in the sides of the base. See Figures 12 and 13. Adjust the extensions to the desired length.

Secure them in place by positioning a clamp bracket under each table extension beneath the miter table. Orient each clamp bracket as shown in figure 13.

Secure each clamp bracket in place with a clamp bracket screw. The clamp bracket screw threads through the clamp bracket and tightens against bracket support on bottom of miter table, securing clamp bracket against table extension.

## STOP BLOCK

See Figures 11 and 14.

The stop block is included with the table extensions and is useful as a stop for making repetitive cuts to the same length. It can be installed on either side of the saw base:

- Slide the stop block on the back arm of either table extension, then insert the table extensions into the saw base.
- Use the small wing screw to secure the stop block to the table extensions.
- Loosen the small wing screw and adjust the stop block the desired distance from the blade for the cut to be made. For accurate placement of the stop block, measure the distance from the teeth set on the blade to the stop block.
- Tighten wing screw securely.
- Plug the saw in.
- Make a test cut in scrap material and measure the length of the workpiece.
- Make any necessary adjustments.

### **⚠ WARNING:**

Always make sure your miter saw is securely mounted to a workbench or an appropriate workstand. Failure to do so could result in an accident resulting in possible serious personal injury.

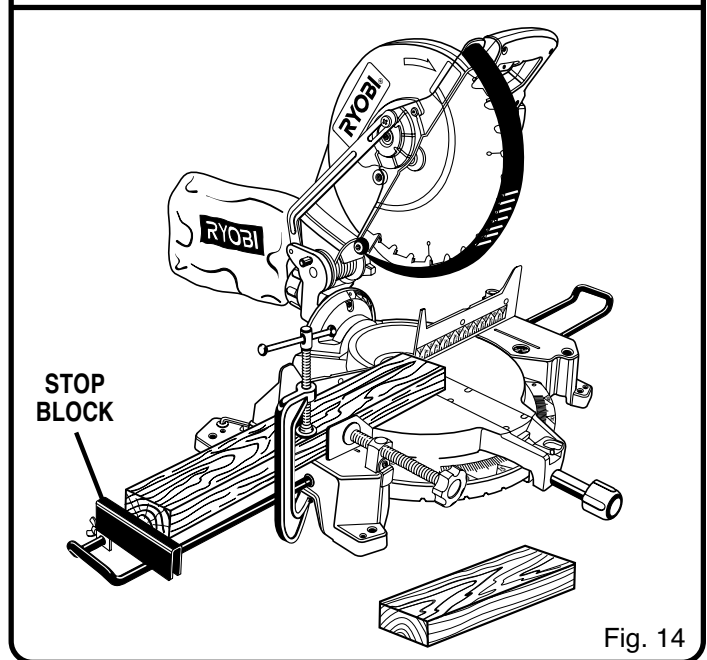
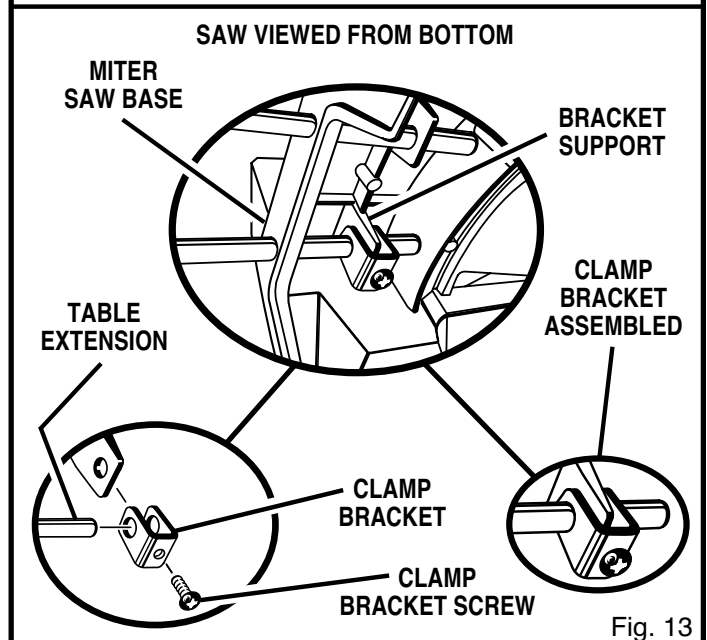
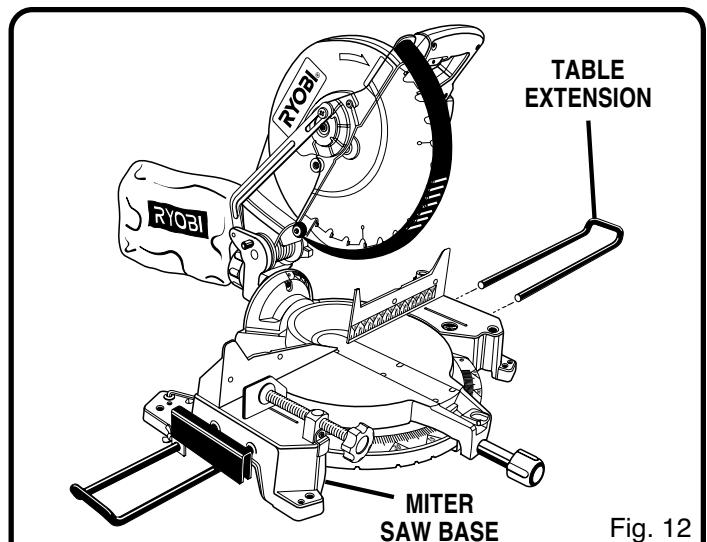
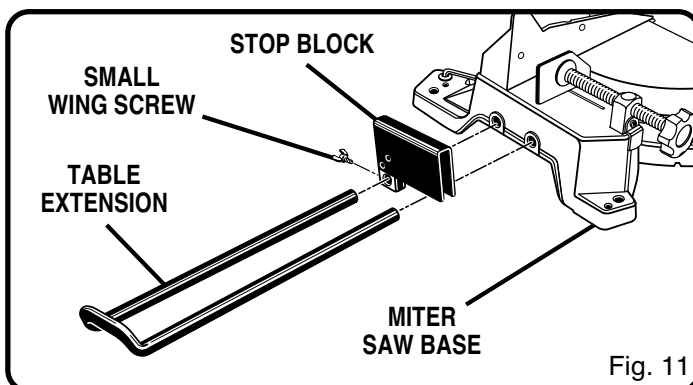

# ASSEMBLY

## TO INSTALL BLADE

See Figures 15 and 16.

(See pages 27 and 28 for Mounting the Laser Guide.)

### **⚠ WARNING:**

A 12 in. (305 mm) blade is the maximum blade capacity of your saw. Never use a blade that is too thick to allow outer blade washer to engage with the flats on the spindle. Larger blades will come in contact with the blade guards, while thicker blades will prevent the blade bolt from securing the blade on the spindle. Either of these situations could result in a serious accident and can cause serious personal injury.

- Unplug your saw.

### **⚠ WARNING:**

Failure to unplug your saw could result in accidental starting causing possible serious personal injury.

- Raise saw arm.
- Loosen screw A on the blade bolt cover.
- Rotate lower blade guard up and remove screw B. Rotate blade bolt cover up and back to expose the blade bolt. See Figure 16.
- Depress the spindle lock button and rotate the blade bolt until the spindle locks.
- Using the wrench provided, loosen and remove the blade bolt. See Figure 15.

**Note:** The blade bolt has left hand threads. Turn blade bolt clockwise to loosen.

- Remove outer blade washer. **Do not** remove inner blade washer.
- Wipe a drop of oil onto inner blade washer and outer blade washer where they contact the blade.

### **⚠ WARNING:**

If inner blade washer has been removed, replace it before placing blade on spindle. Failure to do so could cause an accident since blade will not tighten properly.

- Fit saw blade inside lower blade guard and onto spindle. The blade teeth point downward at the front of saw as shown in Figure 16.
- Replace outer blade washer. The double "D" flats on the blade washers align with the flats on the spindle.
- Depress spindle lock button and replace blade bolt.

**Note:** The blade bolt has left hand threads. Turn blade bolt counterclockwise to tighten.

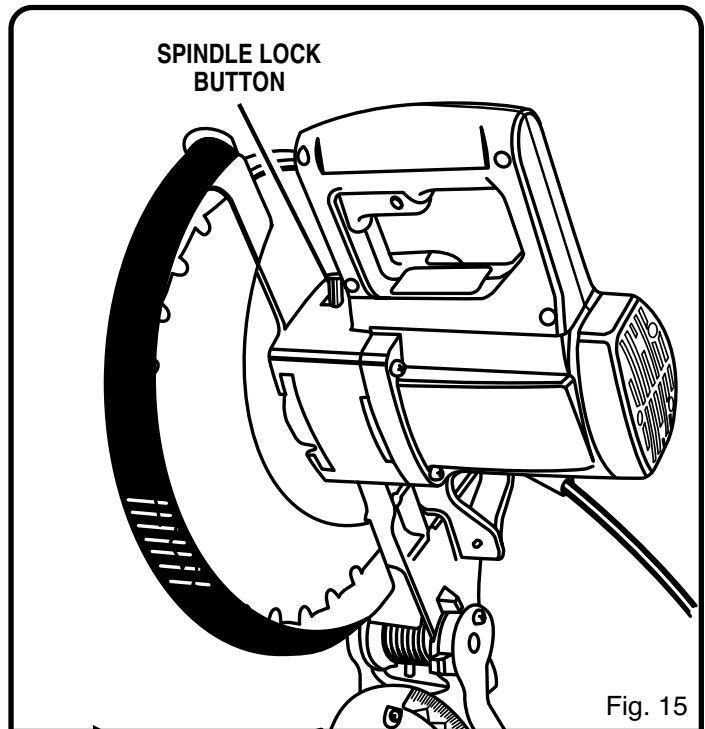

Fig. 15

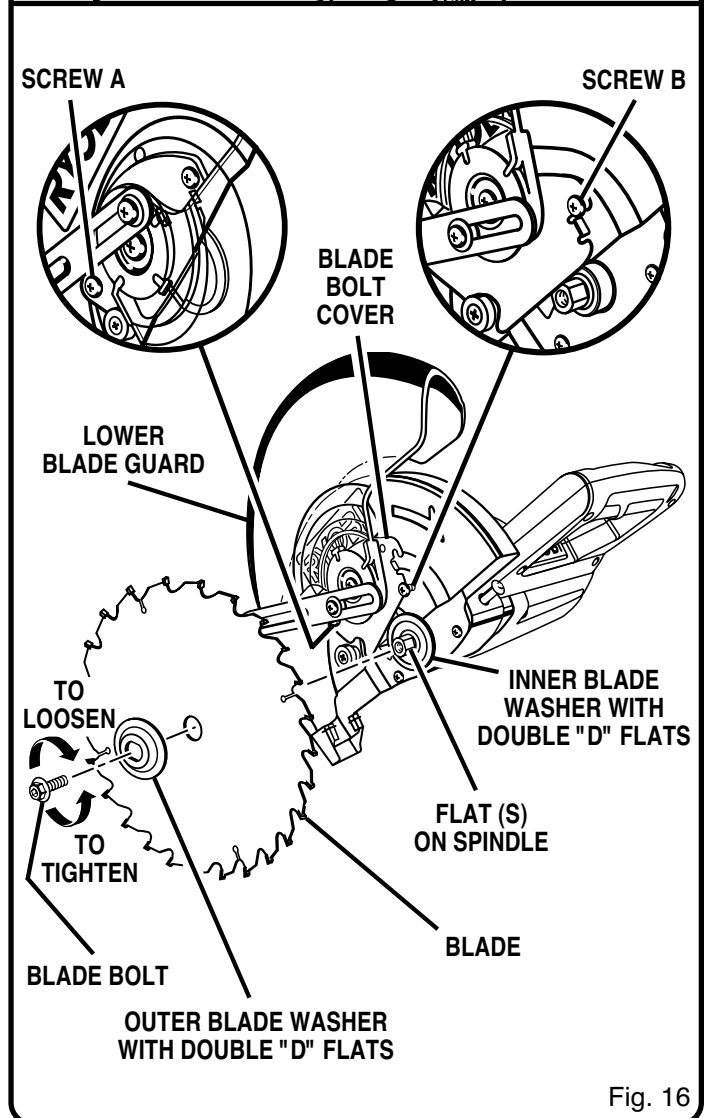

Fig. 16

# ASSEMBLY

## ⚠ CAUTION:

Always install the blade with the blade teeth and the arrow printed on the side of the blade pointing down at the front of the saw. The direction of blade rotation is also stamped with an arrow on the upper blade guard.

- Tighten blade bolt securely.
- Replace the lower blade guard and blade bolt cover.
- Replace screw B and tighten securely.
- Retighten screw A securely.

## ⚠ WARNING:

Make sure the spindle lock button is not engaged before reconnecting saw into power source. Never engage spindle lock button when blade is rotating.

Your compound miter saw has been adjusted at the factory for making very accurate cuts. However, some of the components might have been jarred out of alignment during shipping. Also, over a period of time, readjustment will probably become necessary due to wear. After unpacking your saw, check the following adjustments before you begin using saw. Make any readjustments that are necessary and periodically check the parts alignment to make sure that your saw is cutting accurately.

## ⚠ WARNING:

Your saw should never be connected to power supply when you are assembling parts, making adjustments, installing or removing blades, or when not in use. Disconnecting your saw will prevent accidental starting that could cause serious injury.

# ADJUSTMENTS

**Note:** Many of the illustrations in this manual show only portions of your compound miter saw. This is intentional so that we can clearly show points being made in the illustrations. Never operate your saw without all guards securely in place and in good operating condition.

## SQUARING THE MITER TABLE TO THE FENCE

See Figures 17 - 20.

**Note:** See page 19 for Cutting a Slot in the Zero Clearance Throat Plate.

- Unplug your saw.

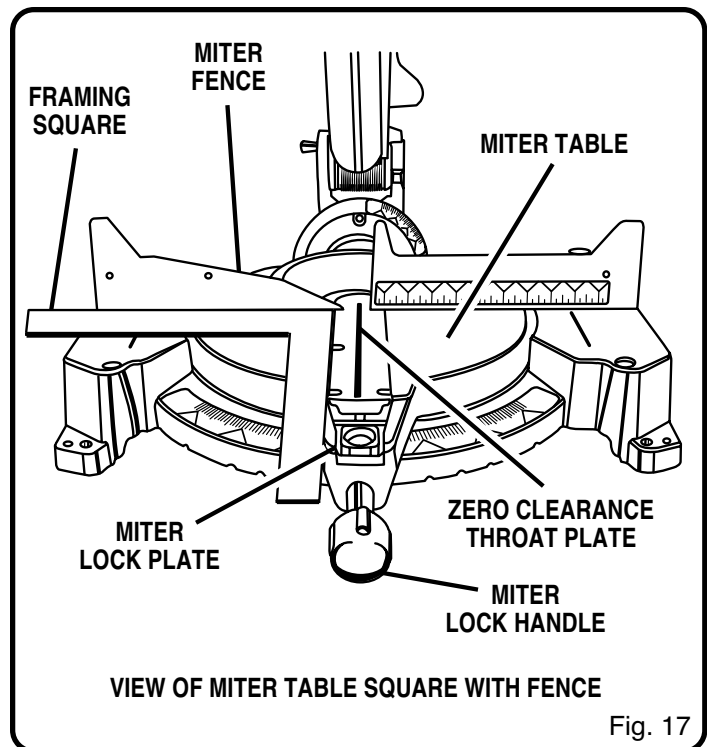

Fig. 17

# ADJUSTMENTS

- Push down on the saw arm and pull out the lock pin to release the saw arm.
- Raise saw arm to its full raised position.
- Loosen the miter lock handle approximately one-half turn.
- Depress the miter lock plate and rotate the miter table until the pointer on the control arm is positioned at 0°.
- Release the miter lock plate and securely tighten the miter lock handle.
- Lay a framing square flat on the miter table. Place one leg of the square against the fence. Place the other leg of the square beside the zero clearance throat plate in the miter table. The edge of the square and the zero clearance throat plate in the miter table should be parallel as shown in figure 19.
- If the edge of the framing square and the zero clearance throat plate in the miter table are not parallel as shown in figures 18 and 19, adjustments are needed.
- Using the blade wrench provided, loosen the socket head screws securing the fence. See Figure 20. Adjust the fence left or right until the framing square and zero clearance throat plate are parallel.
- Retighten the screws securely and recheck the fence-to-table alignment.

## SQUARING THE SAW BLADE TO THE FENCE

See Figures 20 - 24

- Unplug your saw.

### **⚠ WARNING:**

Failure to unplug your saw could result in accidental starting causing possible serious personal injury.

- Pull the saw arm all the way down and engage the lock pin to hold the saw arm in transport position.
- Loosen the miter lock handle approximately one-half turn.
- Depress the miter lock plate and rotate the miter table until the pointer on the control arm is positioned at 0°.
- Release the miter lock plate and securely tighten the miter lock handle.
- Lay a framing square flat on the miter table. Place one leg of the square against the fence. Slide the other leg of the square against the flat part of saw blade.

**Note:** Make sure that the square contacts the flat part of the saw blade, not the blade teeth.

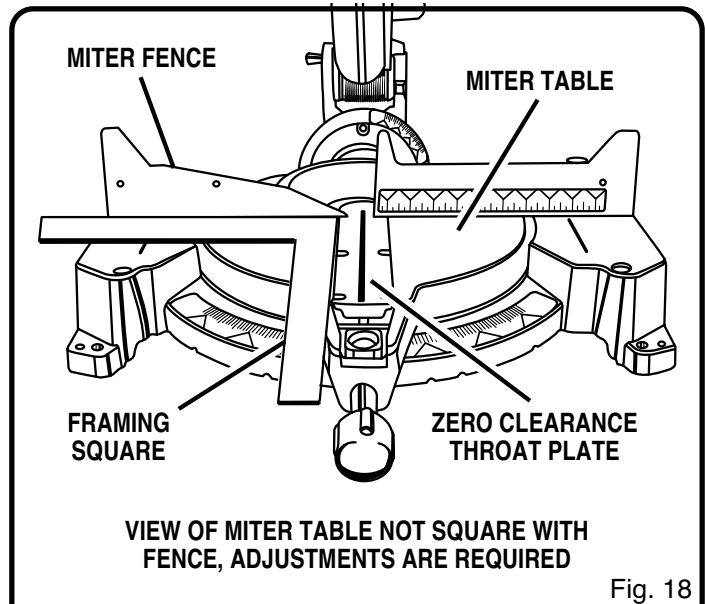

Fig. 18

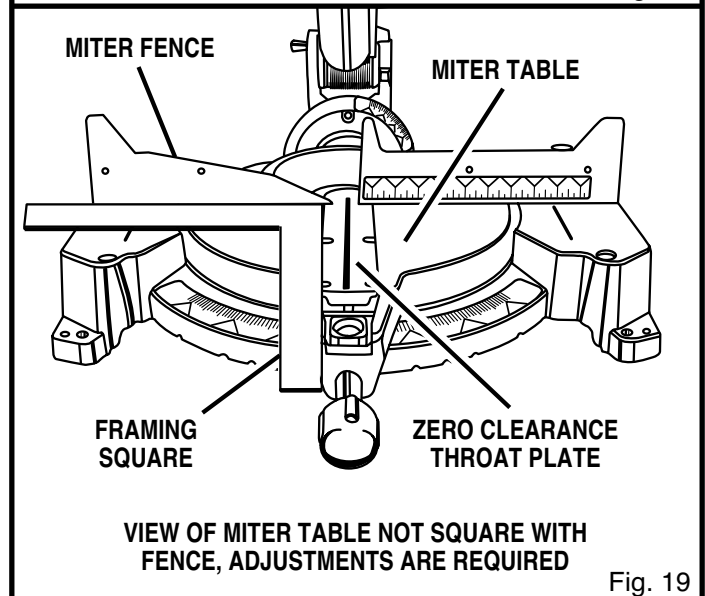

Fig. 19

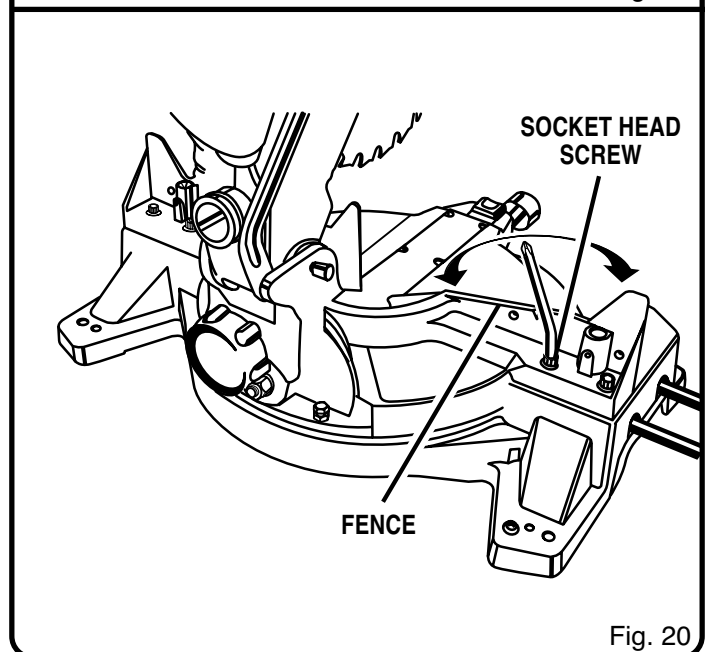

Fig. 20



# ADJUSTMENTS

- The edge of the square and the saw blade should be parallel as shown in figure 21.
- If the front or back edge of the saw blade angles away from the square as shown in figures 22 and 23, adjustments are needed.
- Loosen the socket head screws that secure the miter fence to the miter table. See Figure 20.
- Rotate the miter fence left or right until the saw blade is parallel with the square.
- Retighten the screws securely and recheck the blade-to-fence alignment.

Your saw has two scale indicators, one on the bevel scale and one on the miter scale. After squaring adjustments have been made, it may be necessary to loosen the indicators screws and reset them to zero. See Figure 24.

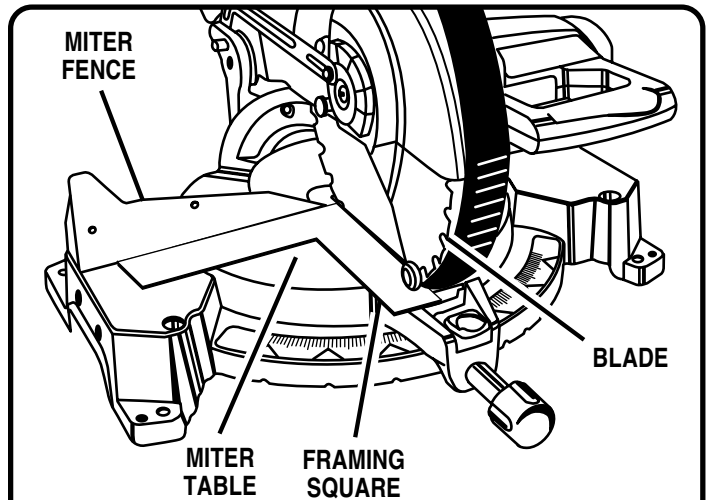

VIEW OF BLADE NOT SQUARE WITH FENCE, ADJUSTMENTS ARE REQUIRED

Fig. 22

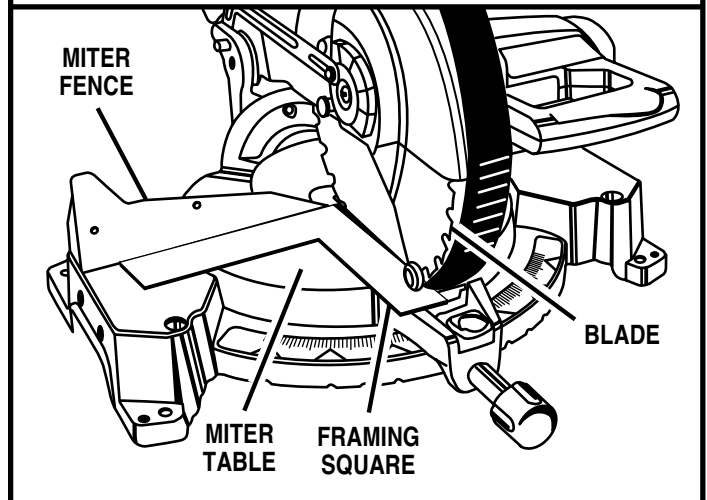

VIEW OF BLADE NOT SQUARE WITH FENCE, ADJUSTMENTS ARE REQUIRED

Fig. 23

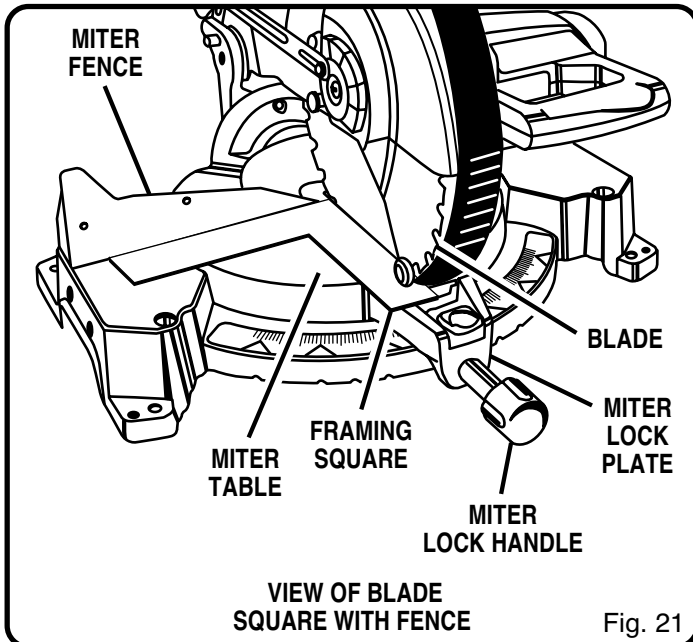

VIEW OF BLADE SQUARE WITH FENCE

Fig. 21

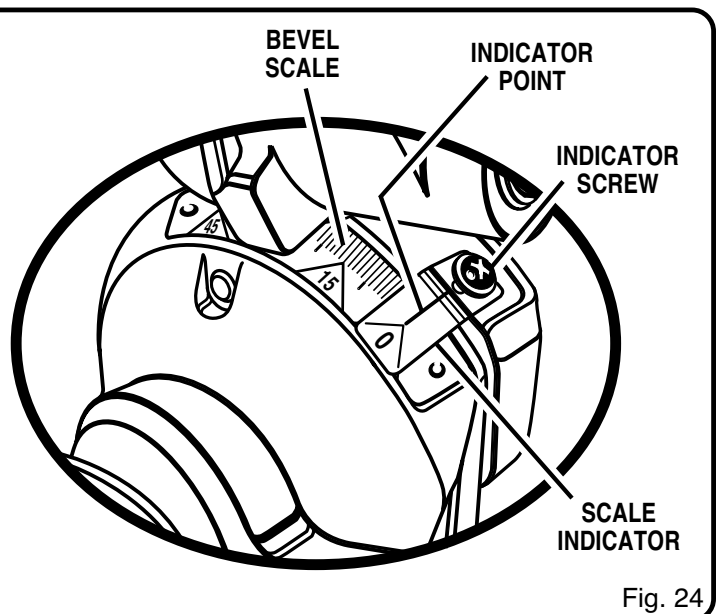
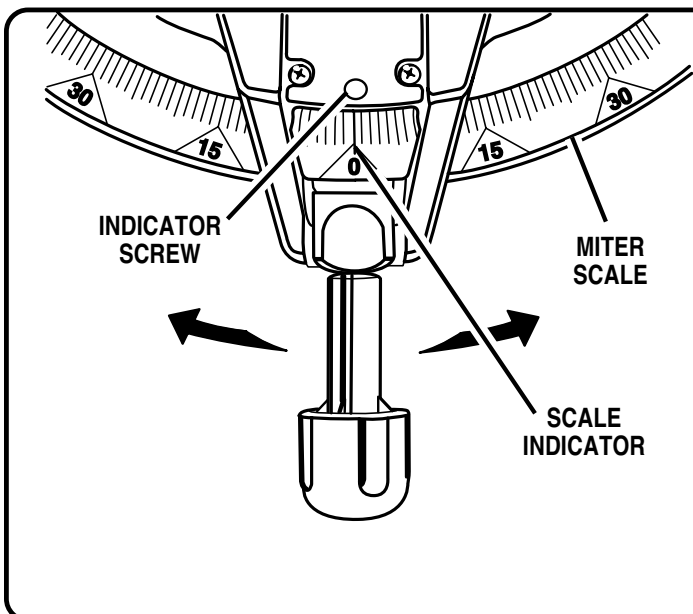

Fig. 24

# ADJUSTMENTS

## SQUARING THE BLADE TO THE MITER TABLE

See Figures 25 - 27.

- Unplug your saw.

### **⚠ WARNING:**

Failure to unplug your saw could result in accidental starting causing possible serious personal injury.

- Pull the saw arm all the way down and engage the lock pin to hold the saw arm in transport position.
- Loosen the miter lock handle approximately one-half turn.
- Depress the miter lock plate and rotate the miter table until the pointer on the control arm is positioned at 0°.
- Release the miter lock plate and securely tighten the miter lock handle.
- Loosen bevel lock knob and set saw arm at 0° bevel (blade set 90° to miter table). Tighten bevel lock knob.
- Place a combination square against the miter table and the flat part of saw blade.

**Note:** Make sure that the square contacts the flat part of the saw blade, not the blade teeth.

- Rotate the blade by hand and check the blade-to-table alignment at several points.
- The edge of the square and the saw blade should be parallel as shown in figure 25.
- If the top or bottom of the saw blade angles away from the square as shown in figures 26 and 27, adjustments are needed.
- Loosen the lock nut securing positive stop adjustment screw. Also loosen bevel lock knob.

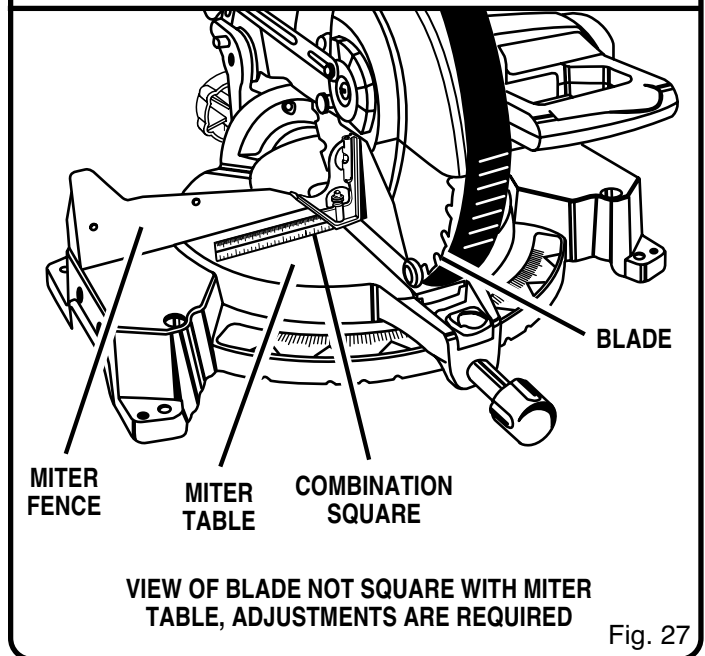
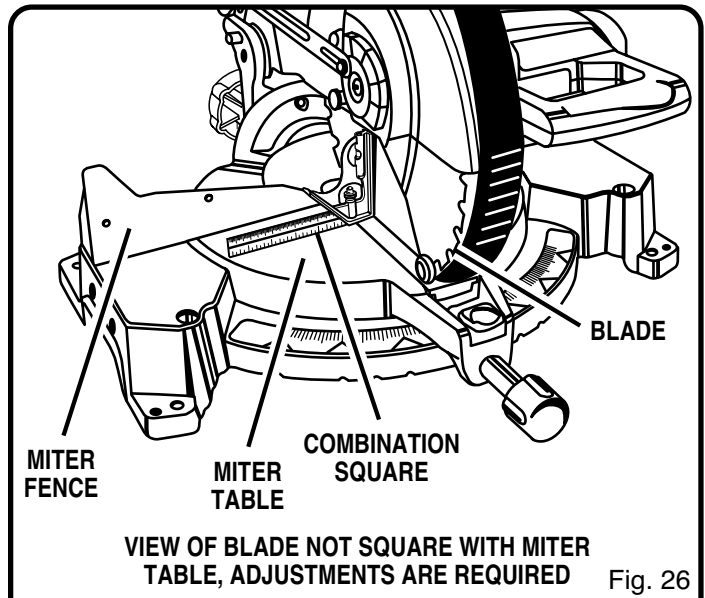
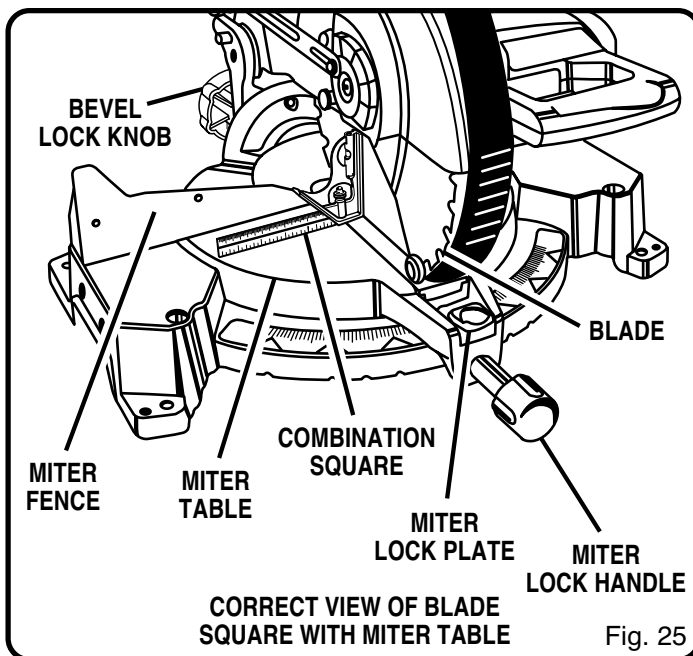

- Adjust positive stop adjustment screw to bring saw blade into alignment with the square. See Figure 28.
- Retighten bevel lock knob. Next, retighten lock nut securing the positive stop adjustment screw. Recheck blade-to-table alignment.

**Note:** The above procedure can be used to check blade squareness of the saw blade to the miter table at both 0° and 45° angles.

Your saw has two scale indicators, one on the bevel scale and one on the miter scale. After squaring adjustments have been made, it may be necessary to loosen the indicator screws and reset them to zero. See Figure 24.

# ADJUSTMENTS

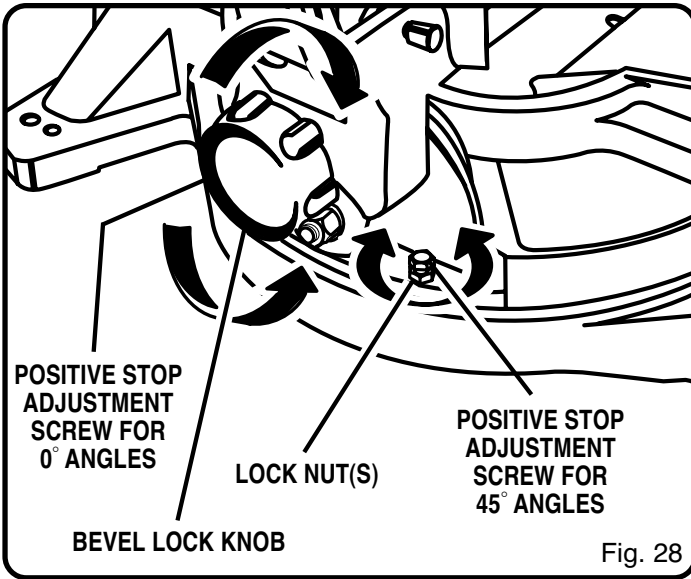

## BEVEL PIVOT ADJUSTMENT

- Your compound miter saw should bevel easily by loosening the bevel lock knob and tilting the saw arm to the left.
- If movement is tight or if there is play in the pivot, have saw repaired by at your nearest **RYOBI AUTHORIZED SERVICE CENTER**.

### **⚠ WARNING:**

Do not start your compound miter saw without checking for interference between the blade and the miter table support. Damage could result to the blade if it strikes the miter table support during operation of the saw.

## APPLICATIONS

(Use only for the purposes listed below)

- Cross cutting wood and plastic.
- Cross cutting miters, joints, etc. for picture frames, moldings, door casings, and fine joinery.

**Note:** The blade provided is fine for most wood cutting operations, but for fine joinery cuts or cutting plastic, use one of the accessory blades available from your Ryobi dealer.

## PIVOT ADJUSTMENTS

**Note:** These adjustments were made at the factory and normally do not require readjustment.

### TRAVEL PIVOT ADJUSTMENT

- The saw arm should rise completely to the up position by itself.
- If the saw arm does not raise by itself or if there is play in the pivot joints, have saw repaired by at your nearest **RYOBI AUTHORIZED SERVICE CENTER**.

# OPERATION

### **⚠ WARNING:**

Before starting any cutting operation, clamp or bolt your miter saw to a workbench. Never operate your miter saw on the floor or in a crouched position. Failure to heed this warning can result in serious personal injury.

### **⚠ WARNING:**

To avoid serious personal injury, keep your hands outside the no hands zone; at least 3 in. (7.6 cm) from blade. Never perform any cutting operation freehand (without holding workpiece against the fence). The blade could grab the workpiece if it slips or twists.

## CUTTING A SLOT IN THE ZERO CLEARANCE THROAT PLATE

In order to use your compound miter saw, you must cut a slot through the zero clearance throat plate to allow for blade clearance. To cut the slot, set your saw at 0° miter, turn saw on and allow the blade to reach full speed, then carefully make a straight cut as far as it will go through the throat plate. Turn your saw off and allow the blade to come to a complete stop before raising the saw arm.

Next, adjust the bevel angle to 45°, turn your saw on and allow the blade to reach full speed, then carefully make another cut through the zero clearance throat plate. The slot in the throat plate will then be wide enough to allow the blade to pass through it at any angle from 0° to 45°.

# OPERATION

## CUTTING WITH YOUR COMPOUND MITER SAW

### **⚠ WARNING:**

When using a work clamp or C-clamp to secure your workpiece, clamp workpiece on one side of the blade only. The workpiece must remain free on one side of the blade to prevent the blade from binding in workpiece. The workpiece binding the blade will cause motor stalling and kickback. This situation could cause an accident resulting in possible serious personal injury.

## CROSSCUTTING

See Figure 29.

A crosscut is made by cutting across the grain of the workpiece. A straight crosscut is made with the miter table set at the 0° position. Miter crosscuts are made with the miter table set at some angle other than zero.

## TO CROSSCUT WITH YOUR MITER SAW

- Pull out the lock pin and lift saw arm to its full height.
- Loosen the miter lock handle. Rotate the miter lock handle approximately one-half turn to the left to loosen.
- Press the miter lock plate down with your thumb and hold.
- Rotate the control arm until the pointer aligns with the desired angle on the miter scale.
- Release the miter lock plate.

**Note:** You can quickly locate 0°, 22-1/2° left or right, and 45° left or right by releasing the lock plate as you rotate the control arm. The lock plate will seat itself in one of the positive stop notches, located in the miter table frame.

- Tighten the miter lock handle securely.

### **⚠ WARNING:**

To avoid serious personal injury, always tighten the miter lock handle securely before making a cut. Failure to do so could result in movement of the control arm or miter table while making a cut.

- Place the workpiece flat on the miter table with one edge securely against the fence. If the board is warped, place the convex side against the fence. If the concave edge of a board is placed against the fence, the board could collapse on the blade at the end of the cut, jamming the blade. See Figures 36 and 37.
- When cutting long pieces of lumber or molding, support the opposite end of the stock with a roller stand or with a work surface level with the saw table. See Figure 34.
- Align cutting line on the workpiece with the edge of saw blade.
- Grasp the stock firmly with one hand and secure it against the fence. Use the optional work clamp or a C-clamp to secure the workpiece when possible. See Figure 29.

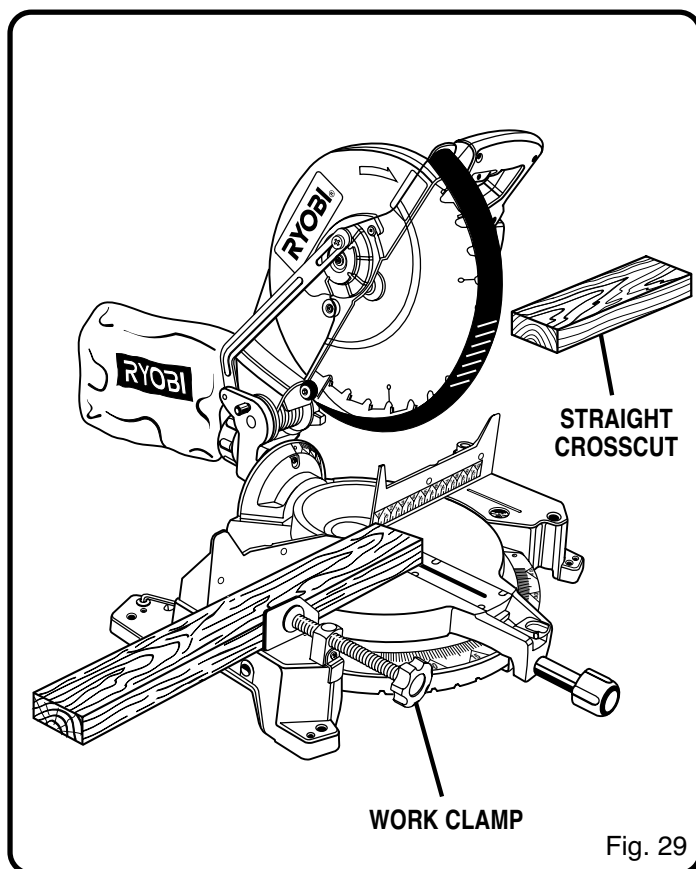

Fig. 29

# OPERATION

- Before turning on the saw, perform a dry run of the cutting operation just to make sure that no problems will occur when the cut is made.
- Grasp the saw handle firmly then squeeze the switch trigger. Allow several seconds for the blade to reach maximum speed.
- Slowly lower the blade into and through the workpiece. See Figure 29.
- Release the switch trigger and allow the saw blade to stop rotating before raising the blade out of workpiece. Wait until the electric brake stops blade from turning before removing the workpiece from the miter table.

## BEVEL CUT

See Figures 30 and 31.

A bevel cut is made by cutting across the grain of the workpiece with the blade set at an angle. A straight bevel cut is made with the miter table set at the zero degree position and the blade set at an angle between 0° and 45°.

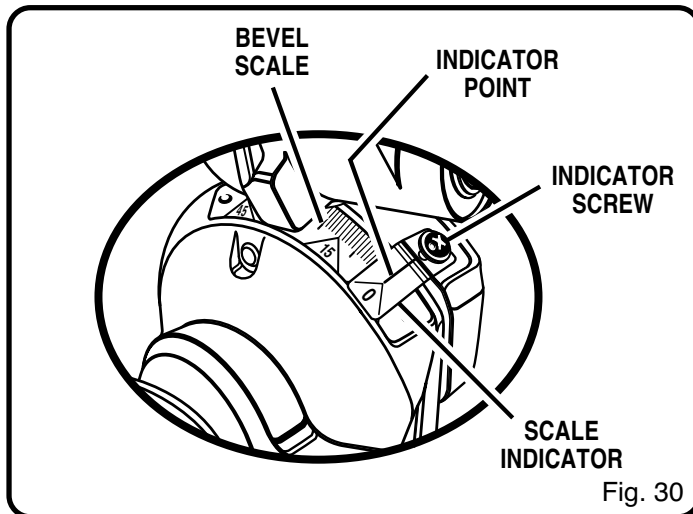

- Pull out the lock pin and lift saw arm to its full height.
- Loosen the miter lock handle. Rotate the miter lock handle approximately one-half turn to the left to loosen.
- Press the miter lock plate down with your thumb and hold.
- Rotate the control arm until the pointer aligns with zero on the miter scale.
- Release the miter lock plate.

**Note:** You can quickly locate zero by releasing the lock plate as you rotate the control arm. The lock plate will seat itself in one of the built-in positive stop notches, located in the miter table frame.

- Tighten the miter lock handle securely.

### **⚠ WARNING:**

To avoid serious personal injury, always tighten the miter lock handle securely before making a cut. Failure to do so could result in movement of the control arm or miter table while making a cut.

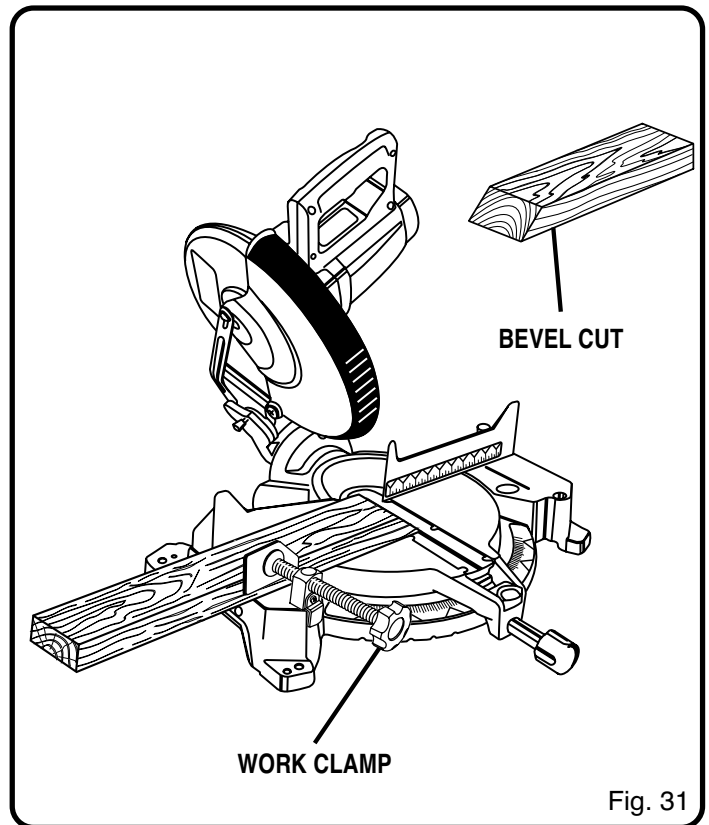

- The 45° triangle on the miter fence provides for the maximum clearance required for adjusting the miter saw's angle when making a bevel or compound cut.
- Loosen the bevel lock knob and move the saw arm to the left to the desired bevel angle.
- Bevel angles can be set from 0° to 45°.
- Once the saw arm has been set at the desired angle, securely tighten the bevel lock knob.
- Place the workpiece flat on the miter table with one edge securely against the fence. If the board is warped, place the convex side against the fence. If the concave edge of a board is placed against the fence, the board could collapse on the blade at the end of the cut, jamming the blade. See Figures 36 and 37.
- When cutting long pieces of lumber or molding, support the opposite end of the stock with a roller stand or with a work surface level with the saw table. See Figure 34.
- Align the cutting line on the workpiece with the edge of saw blade.

# OPERATION

- Grasp the stock firmly with one hand and secure it against the fence. Use the optional work clamp or a C-clamp to secure the workpiece when possible. See Figure 31.

## **⚠ WARNING:**

To avoid serious personal injury, always keep your hands outside the no hands zone; at least 3 in. (7.6 cm) from blade. Never perform any cutting operation freehand (without holding workpiece against the fence). The blade could grab the workpiece if it slips or twists.

- Before turning on the saw, perform a dry run of the cutting operation just to make sure that no problems will occur when the cut is made.
- Grasp the saw handle firmly then squeeze the switch trigger. Allow several seconds for the blade to reach maximum speed.
- Slowly lower the blade into and through the workpiece. See Figure 31.
- Release the switch trigger and allow the saw blade to stop rotating before raising the blade out of workpiece. Wait until the electric brake stops blade from turning before removing the workpiece from miter table.

## COMPOUND MITER CUT

A compound miter cut is a cut made using a miter angle and a bevel angle at the same time. This type of cut is used to make picture frames, cut molding, make boxes with sloping sides, and for certain roof framing cuts.

To make this type of cut the control arm on the miter table must be rotated to the correct angle and the saw arm must be tilted to the correct bevel angle. Care should always be taken when making compound miter setups due to the interaction of the two angle settings.

Adjustments of miter and bevel settings are interdependent with one another. Each time you adjust the miter setting you change the effect of the bevel setting. Also, each time you adjust the bevel setting you change the effect of the miter setting.

It may take several settings to obtain the desired cut. The first angle setting should be checked after setting the second angle, since adjusting the second angle affects the first.

Once the two correct settings for a particular cut have been obtained, always make a test cut in scrap material before making a finish cut in good material.

## TO MAKE A COMPOUND CUT WITH YOUR MITER SAW

- Pull out the lock pin and lift saw arm to its full height.
- Loosen the miter lock handle. Rotate the miter lock handle approximately one-half turn to the left to loosen.
- Press the miter lock plate down with your thumb and hold.
- Rotate the control arm until the pointer aligns with the desired angle on the miter scale.

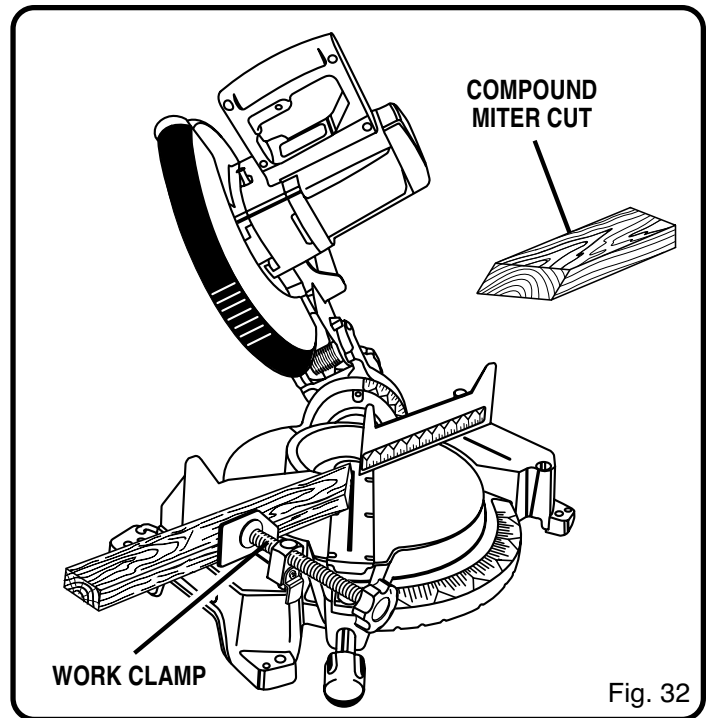

- Release the miter lock plate.

**Note:** You can quickly locate 0°, 15°, 22-1/2°, left or right, 30° and 45° left or right by releasing the miter lock plate as you rotate the control arm. The miter lock plate will seat itself in one of the positive stop notches, located in miter table frame.

- Tighten the miter lock handle securely.

## **⚠ WARNING:**

To avoid serious personal injury, always tighten the miter lock handle securely before making a cut. Failure to do so could result in movement of the control arm or miter table while making a cut.

- Loosen the bevel lock knob and move the saw arm to the left to the desired bevel angle.
- Bevel angles can be set from 0° to 45°.
- Once the saw arm has been set at the desired angle, securely tighten the bevel lock knob.

# OPERATION

- Recheck miter angle setting. Make a test cut in scrap material.
- Place the workpiece flat on the miter table with one edge securely against the fence. If the board is warped, place the convex side against the fence. If the concave edge of a board could collapse on the blade at the end of the cut, jamming the blade. See Figures 36 and 37.
- When cutting long pieces of lumber or molding, support the opposite end of the stock with a roller stand or with a work surface level with the saw table. See Figure 34.
- Align the cutting line on the workpiece with the edge of saw blade.
- Grasp the stock firmly with one hand and secure it against the fence. Use the optional work clamp or a C-clamp to secure the workpiece when possible. See Figure 32.

## **⚠ WARNING:**

To avoid serious personal injury, always keep your hands outside the no hands zone; at least 3 in. (7.6 cm) from blade. Never perform any cutting operation freehand (without holding workpiece against the fence). The blade could grab the workpiece if it slips or twists.

- Before turning on the saw, perform a dry run of the cutting operation just to make sure that no problems will occur when the cut is made.
- Grasp the saw handle firmly then squeeze the switch trigger. Allow several seconds for the blade to reach maximum speed.
- Slowly lower the blade into and through the workpiece. See Figures 32 and 33.
- Release the switch trigger and allow the saw blade to stop rotating before raising the blade out of workpiece. Wait until the electric brake stops blade from turning before removing the workpiece from miter table.

## **SUPPORT LONG WORKPIECES**

See Figure 34.

Long workpieces need extra supports. Supports should be placed along the workpiece so it does not sag. The support should let the workpiece lay flat on the base of the saw and work table during the cutting operation. Use the optional work clamp or a C-clamp to secure the workpiece.

## **⚠ WARNING:**

To avoid serious personal injury, always keep your hands outside the no hands zone; at least 3 in. (7.6 cm) from blade. Never perform any cutting operation freehand (without holding workpiece against the fence). The blade could grab the workpiece if it slips or twists.

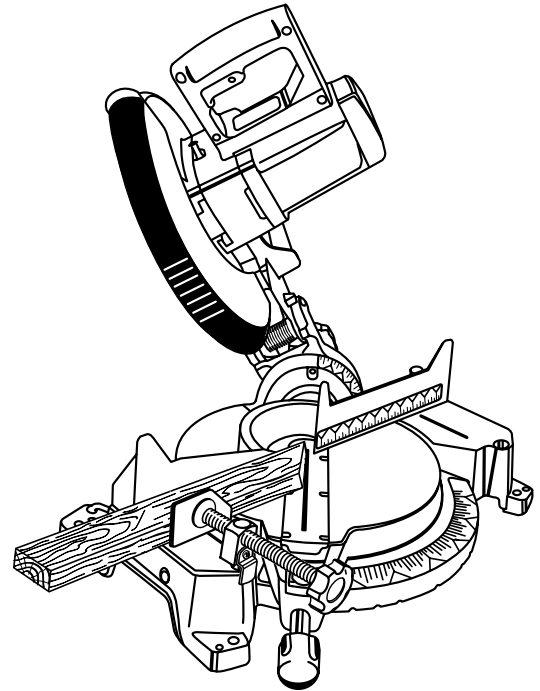

45° x 45° COMPOUND MITER CUT

Fig. 33

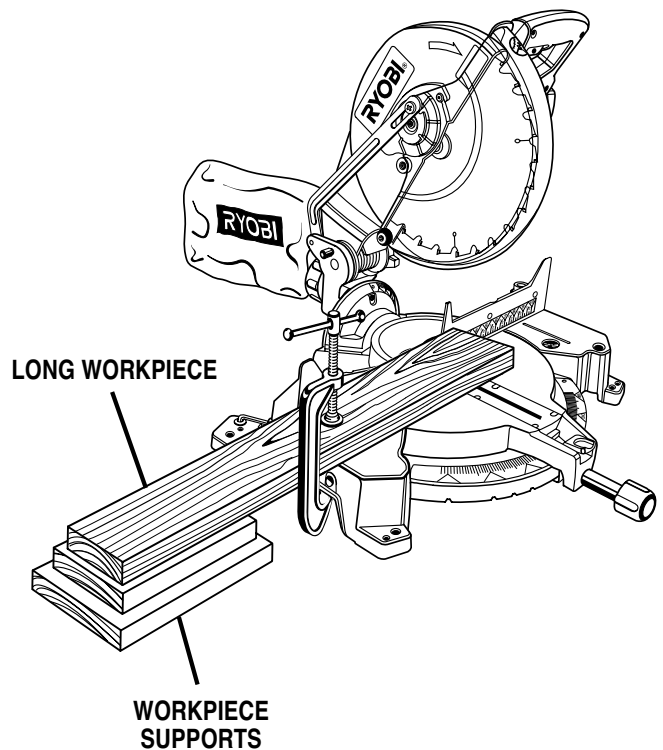

Fig. 34

# OPERATION

## CUTTING COMPOUND MITERS

To aid in making the correct settings, the compound angle setting chart below has been provided. Since compound cuts are the most difficult to accurately obtain, trial cuts should be made in scrap material, and much thought and planning made, prior to making your required cut.

PITCH OF SIDE	NUMBER OF SIDES						
	4	5	6	7	8	9	10
0°	M- 45.00° B- 0.00°	M- 36.00° B- 0.00°	M- 30.00° B- 0.00°	M- 25.71° B- 0.00°	M- 22.50° B- 0.00°	M- 20.00° B- 0.00°	M- 18.00° B- 0.00°
5°	M- 44.89° B- 3.53°	M- 35.90° B- 2.94°	M- 29.91° B- 2.50°	M- 25.63° B- 2.17°	M- 22.42° B- 1.91°	M- 19.93° B- 1.71°	M- 17.94° B- 1.54°
10°	M- 44.56° B- 7.05°	M- 35.58° B- 5.86°	M- 29.62° B- 4.98°	M- 25.37° B- 4.32°	M- 22.19° B- 3.81°	M- 19.72° B- 3.40°	M- 17.74° B- 3.08°
15°	M- 44.01° B- 10.55°	M- 35.06° B- 8.75°	M- 29.15° B- 7.44°	M- 24.95° B- 6.45°	M- 21.81° B- 5.68°	M- 19.37° B- 5.08°	M- 17.42° B- 4.59°
20°	M- 43.22° B- 14.00°	M- 34.32° B- 11.60°	M- 28.48° B- 9.85°	M- 24.35° B- 8.53°	M- 21.27° B- 7.52°	M- 18.88° B- 6.72°	M- 16.98° B- 6.07°
25°	M- 42.19° B- 17.39°	M- 33.36° B- 14.38°	M- 27.62° B- 12.20°	M- 23.56° B- 10.57°	M- 20.58° B- 9.31°	M- 18.26° B- 8.31°	M- 16.41° B- 7.50°
30°	M- 40.89° B- 20.70°	M- 32.18° B- 17.09°	M- 26.57° B- 14.48°	M- 22.64° B- 12.53°	M- 19.73° B- 11.03°	M- 17.50° B- 9.85°	M- 15.72° B- 8.89°
35°	M- 39.32° B- 23.93°	M- 30.76° B- 19.70°	M- 25.31° B- 16.67°	M- 21.53° B- 14.41°	M- 18.74° B- 12.68°	M- 16.60° B- 11.31°	M- 14.90° B- 10.21°
40°	M- 37.45° B- 27.03°	M- 29.10° B- 22.20°	M- 23.86° B- 18.75°	M- 20.25° B- 16.19°	M- 17.60° B- 14.24°	M- 15.58° B- 12.70°	M- 13.98° B- 11.46°
45°	M- 35.26° B- 30.00°	M- 27.19° B- 24.56°	M- 22.21° B- 20.70°	M- 18.80° B- 17.87°	M- 16.32° B- 15.70°	M- 14.43° B- 14.00°	M- 12.94° B- 12.62°
50°	M- 32.73° B- 32.80°	M- 25.03° B- 26.76°	M- 20.36° B- 22.52°	M- 17.20° B- 19.41°	M- 14.91° B- 17.05°	M- 13.17° B- 15.19°	M- 11.80° B- 13.69°
55°	M- 29.84° B- 35.40°	M- 22.62° B- 28.78°	M- 18.32° B- 24.18°	M- 15.44° B- 20.82°	M- 13.36° B- 18.27°	M- 11.79° B- 16.27°	M- 10.56° B- 14.66°
60°	M- 26.57° B- 37.76°	M- 19.96° B- 30.60°	M- 16.10° B- 25.66°	M- 13.54° B- 22.07°	M- 11.70° B- 19.35°	M- 10.31° B- 17.23°	M- 9.23° B- 15.52°
65°	M- 22.91° B- 39.86°	M- 17.07° B- 32.19°	M- 13.71° B- 26.95°	M- 11.50° B- 23.16°	M- 9.93° B- 20.29°	M- 8.74° B- 18.06°	M- 7.82° B- 16.26°
70°	M- 18.88° B- 41.64°	M- 13.95° B- 33.53°	M- 11.17° B- 28.02°	M- 9.35° B- 24.06°	M- 8.06° B- 21.08°	M- 7.10° B- 18.75°	M- 6.34° B- 16.88°
75°	M- 14.51° B- 43.08°	M- 10.65° B- 34.59°	M- 8.50° B- 28.88°	M- 7.10° B- 24.78°	M- 6.12° B- 21.69°	M- 5.38° B- 19.29°	M- 4.81° B- 17.37°
80°	M- 9.85° B- 44.14°	M- 7.19° B- 35.37°	M- 5.73° B- 29.50°	M- 4.78° B- 25.30°	M- 4.11° B- 22.14°	M- 3.62° B- 19.68°	M- 3.23° B- 17.72°
85°	M- 4.98° B- 44.78°	M- 3.62° B- 35.84°	M- 2.88° B- 29.87°	M- 2.40° B- 25.61°	M- 2.07° B- 22.41°	M- 1.82° B- 19.92°	M- 1.62° B- 17.93°
90°	M- 0.00° B- 45.00°	M- 0.00° B- 36.00°	M- 0.00° B- 30.00°	M- 0.00° B- 25.71°	M- 0.00° B- 22.50°	M- 0.00° B- 20.00°	M- 0.00° B- 18.00°

Each B (Bevel) and M (Miter) Setting is Given to the Closest 0.005°.

### COMPOUND-ANGLE SETTINGS FOR POPULAR STRUCTURES



# OPERATION

## CUTTING CROWN MOLDING

Your compound miter saw does an excellent job of cutting crown molding. In general, compound miter saws do a better job of cutting crown molding than any other tool made.

In order to fit properly, crown molding must be compound mitered with extreme accuracy.

The two contact surfaces on a piece of crown molding that fit flat against the ceiling and the wall of a room are at angles that, when added together, equal exactly  $90^\circ$ . Most crown molding has a top rear angle (the section that fits flat against the ceiling) of  $52^\circ$  and a bottom rear angle (the section that fits flat against the wall) of  $38^\circ$ .

## LAYING MOLDING FLAT ON THE MITER TABLE

See Figure 35.

To use this method for accurately cutting crown molding for a  $90^\circ$  inside or outside corner, lay the molding with its broad back surface flat on the miter table and against the fence.

When setting the bevel and miter angles for compound miters, remember that the settings are interdependent; changing one angle changes the other angle as well.

Keep in mind that the angles for crown moldings are very precise and difficult to set. Since it is very easy for these angles to shift, all settings should first be tested on scrap molding. Also most walls do not have angles of exactly  $90^\circ$ , therefore, you will need to fine tune your settings.

When cutting crown molding by this method the bevel angle should be set at  $33.85^\circ$ . The miter angle should be set at  $31.62^\circ$  either right or left, depending on the desired cut for the application. See the chart below for correct angle settings and correct positioning of crown molding on miter table.

The settings in the chart below can be used for cutting All Standard (U.S.) crown molding with  $52^\circ$  and  $38^\circ$  angles. The crown molding is placed flat on the miter table using the compound features of your miter saw.

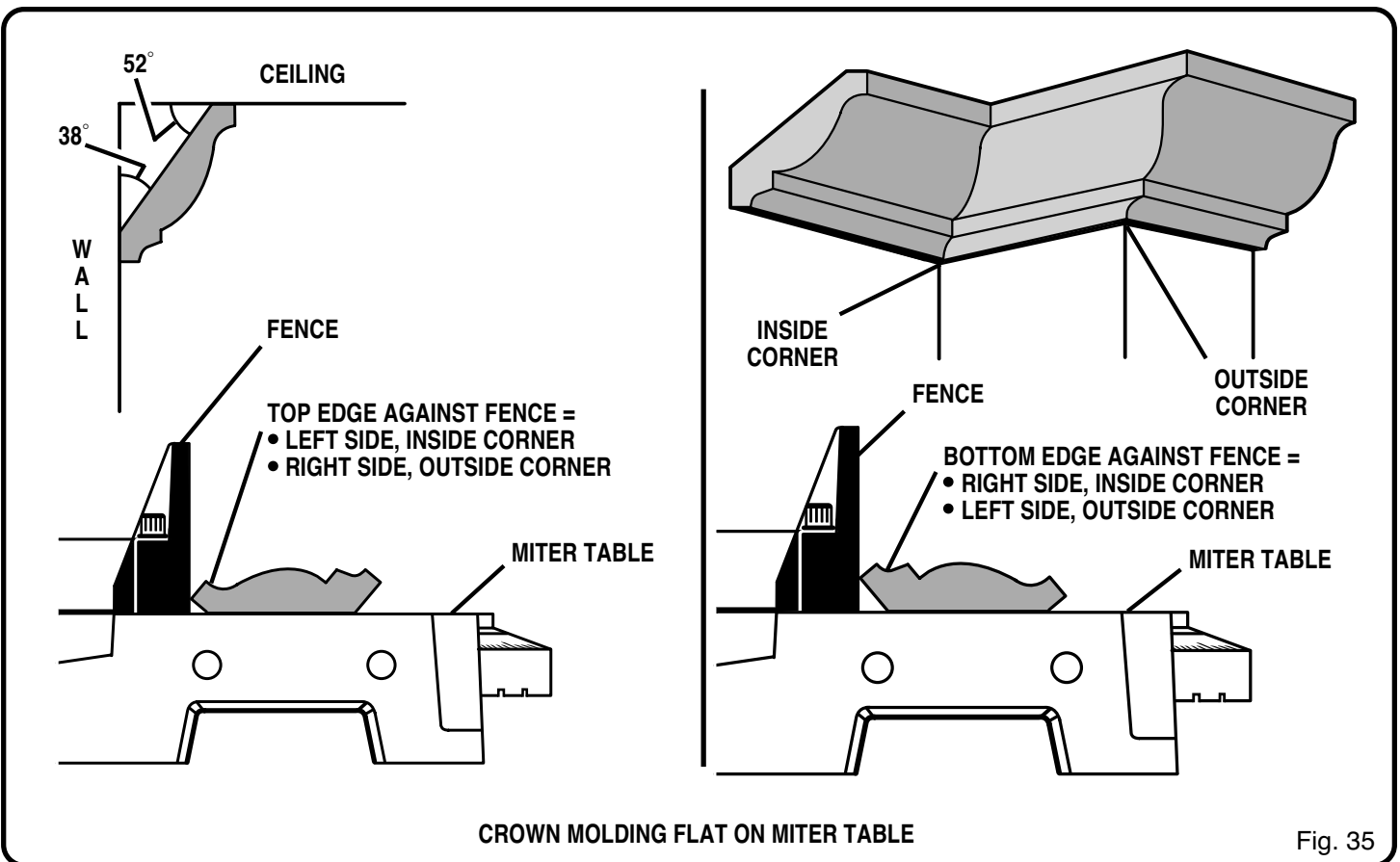

# OPERATION

Bevel Angle Setting	Type of Cut
33.85°	<b>Left side, inside corner</b> 1. Top edge of molding against fence 2. Miter table set right 31.62° 3. Save left end of cut
33.85°	<b>Right side, inside corner</b> 1. Bottom edge of molding against fence 2. Miter table set left 31.62° 3. Save left end of cut
33.85°	<b>Left side, outside corner</b> 1. Bottom edge of molding against fence 2. Miter table set left 31.62° 3. Save right end of cut
33.85°	<b>Right side, outside corner</b> 1. Top edge of molding against fence 2. Miter table set right 31.62° 3. Save right end of cut

## CUTTING WARPED MATERIAL

See Figures 36 and 37.

When cutting warped material, always make sure it is positioned on the miter table with the convex side against the fence as shown in figure 36.

If the warped material is positioned the wrong way as shown in figure 37, it will pinch the blade near the completion of the cut.

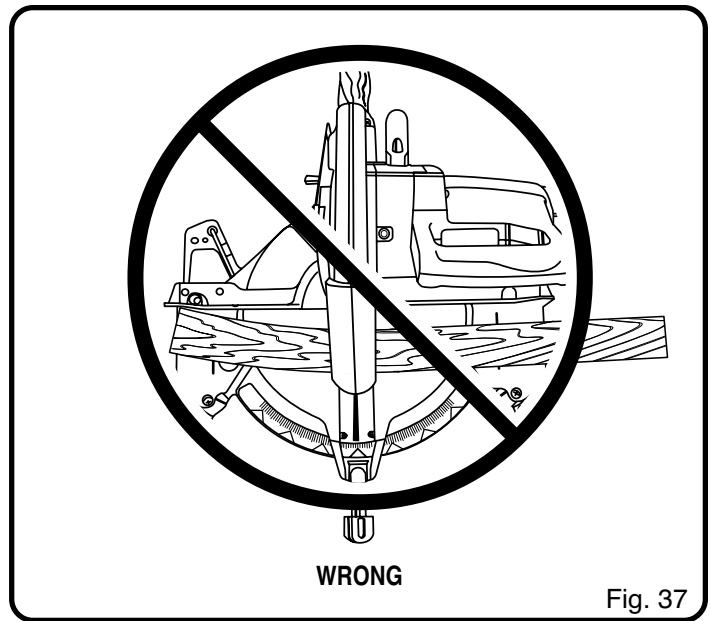
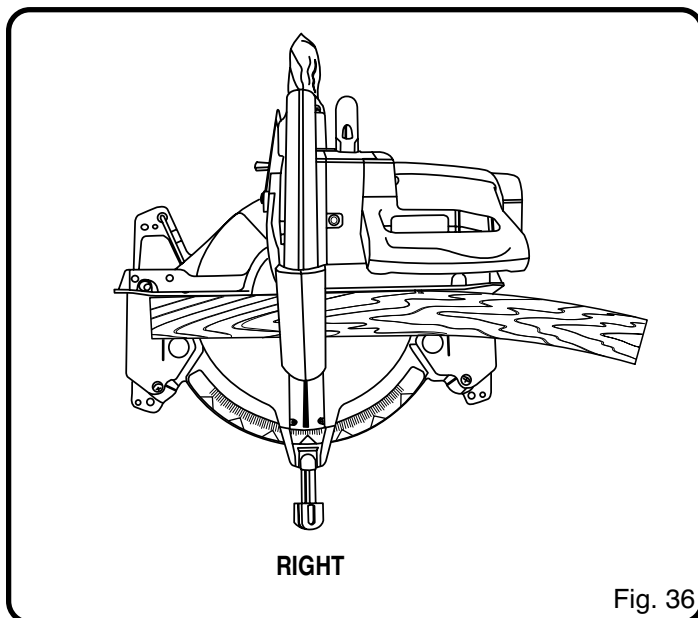

## **WARNING:**

To avoid a binding condition and to avoid serious personal injury, never position the concave edge of bowed or warped material against the fence.

## CLAMPING WIDE WORKPIECES

See Figure 38.

When cutting wide workpieces, such as 6 in. x 2 in. (152 mm x 51 mm), boards should be clamped with a C-clamp as shown in figure 38.

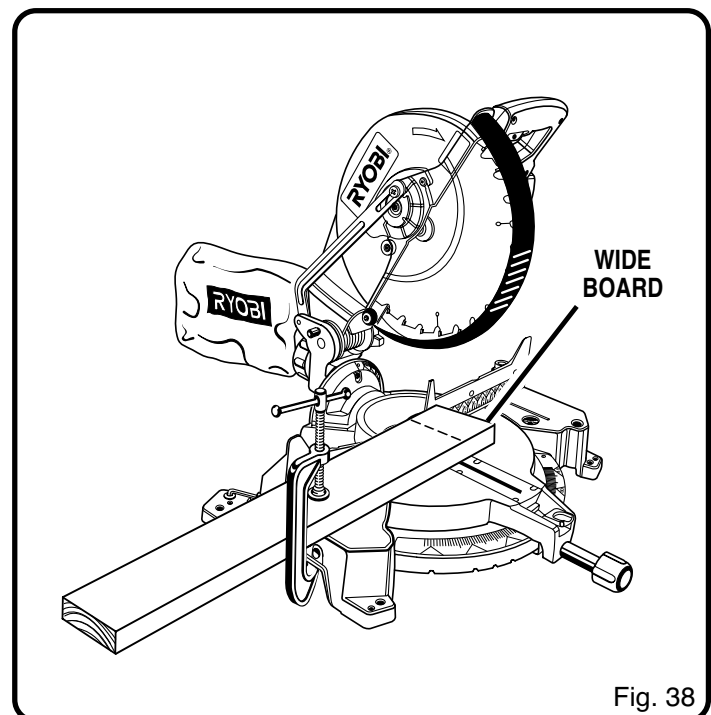

# LASER GUIDE

## MOUNTING THE LASER GUIDE

See Figure 39 .

- Unplug your saw.

### **WARNING:**

Failure to unplug your saw could result in accidental starting causing possible serious personal injury.

See "To Install Blade" in the adjustments section of this operator's manual.

- Make sure inner blade washer is in place before positioning saw blade on the spindle of your saw.

**Note:** The laser guide replaces the outer blade washer.

- Place the laser guide onto the spindle, aligning the double "D" flats in the laser guide with the flats on the spindle.
  - Position flat surface of laser guide against the blade. Warning labels are visible when laser guide is mounted properly.
  - Depress spindle lock button and secure laser guide using **only the special hex key bolt** provided.
- Note:** The hex key bolt has left hand threads. Turn bolt counterclockwise to tighten.
- Using the hex key provided with your saw, tighten bolt securely.
  - Remove the hex key and store it in a safe place for future use.
  - Replace the lower blade guard and blade bolt cover.
  - Retighten phillips screw securing blade bolt cover. Tighten screw securely.

### **DANGER:**

Laser radiation. Avoid direct eye contact with light source.

## OPERATION

See Figure 40.

The laser guide will generate a red colored line on the work surface when the saw blade is spinning above 500 rpm. The red laser line will appear as a broken line on the workpiece when the blade assembly is in the uppermost position and the motor switch is activated. This broken line will let you see your mark and your laser guide line at the same time, and will assist you in lining up your mark for more accurate cutting of the workpiece.

## ALIGNMENT

Align the laser line and your mark with the blade at the uppermost position. Once both lines are in alignment, do not move the workpiece until after you have finished cutting.

As the blade assembly is lowered toward the workpiece, the broken line will become solid.

Make several practice cuts on different styles and thickness of material.

Follow the directions below for using your Laser Guide.

**Removing Your Mark:** (workpiece left of blade)

Position the laser line near the left edge of your mark on the work surface in order to remove the mark.

**To Cut Your Mark:**

Position the laser line near or over your mark on the work surface in order to cut the mark.

**To Leave Your Mark:**

Position the laser line near the right edge of your mark on the work surface in order to leave the mark.

After you have become familiar with using your Laser Guide, you will be able to remove, cut, or leave your mark on the work surface. Practice will teach you the correct position for aligning the laser line with your mark.

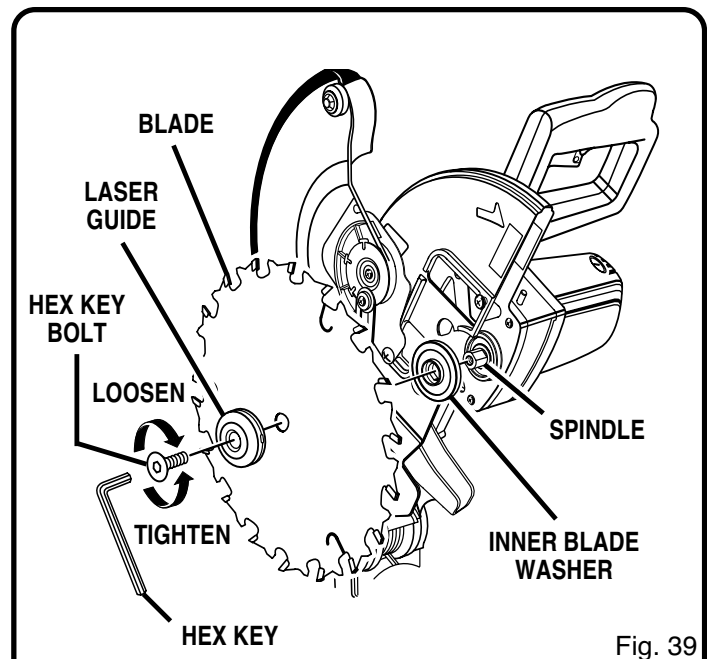

Fig. 39

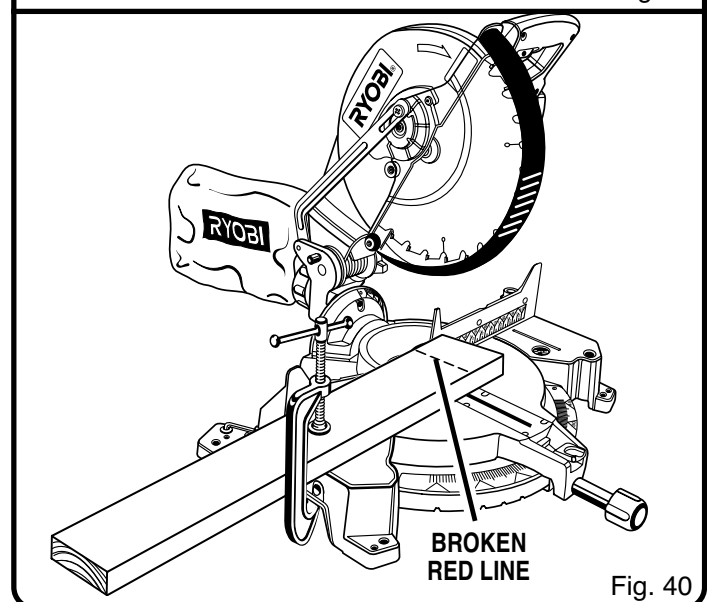

Fig. 40

# LASER GUIDE

## CHANGING THE BATTERIES

See Figure 41.

- Unplug your saw.

### **WARNING:**

Failure to unplug your saw could result in accidental starting causing possible serious personal injury.

Remove the laser guide from the saw. Lay laser guide on a flat surface with the two phillips screws facing upward. Remove the screws and separate the laser guide cover from the laser guide support.

Remove the three button cell batteries using a non-conductive device such as a toothpick.

**Note:** Replace the batteries with button cell batteries that have a rating of 1.5 volt and 100 mah (milliampere hour) minimum (Number 76 series or equivalent).

When replacing the batteries, the laser guide should be thoroughly cleaned. Use a soft paintbrush or similar device, to remove all sawdust and debris.

### **Do not attempt to activate the laser.**

The laser is activated by means of a centrifugal switch only while the saw motor is running and the laser guide is mounted on the saw.

After cleaning laser guide and replacing batteries, secure laser guide cover to laser guide support using the two phillips head screws. For proper assembly, be sure to align the key on the laser guide cover with the key slot in the laser guide support. Tighten screws securely.

**Note:** Aperture in laser guide cover must be aligned with aperture in laser guide support.

### **CAUTION:**

Use of controls or adjustments or performance of procedures other than those specified herein may result in hazardous radiation exposure.

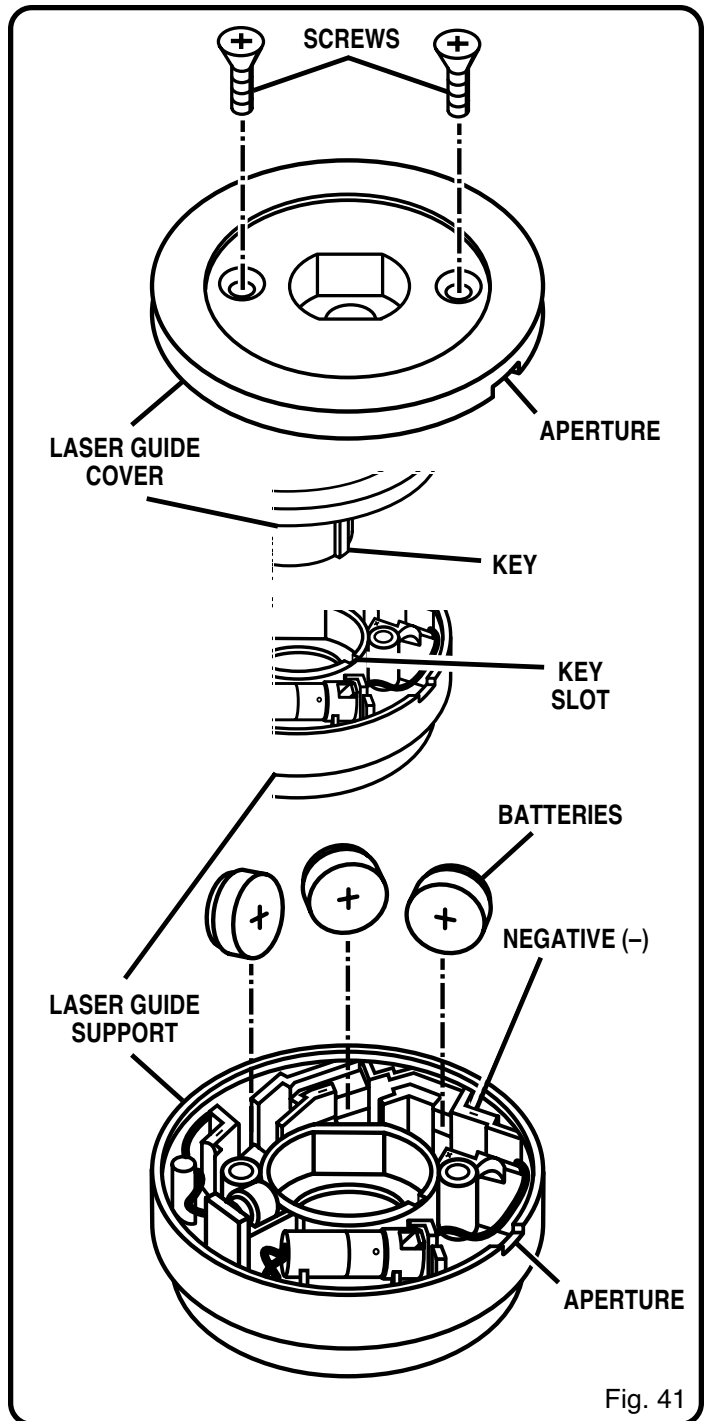
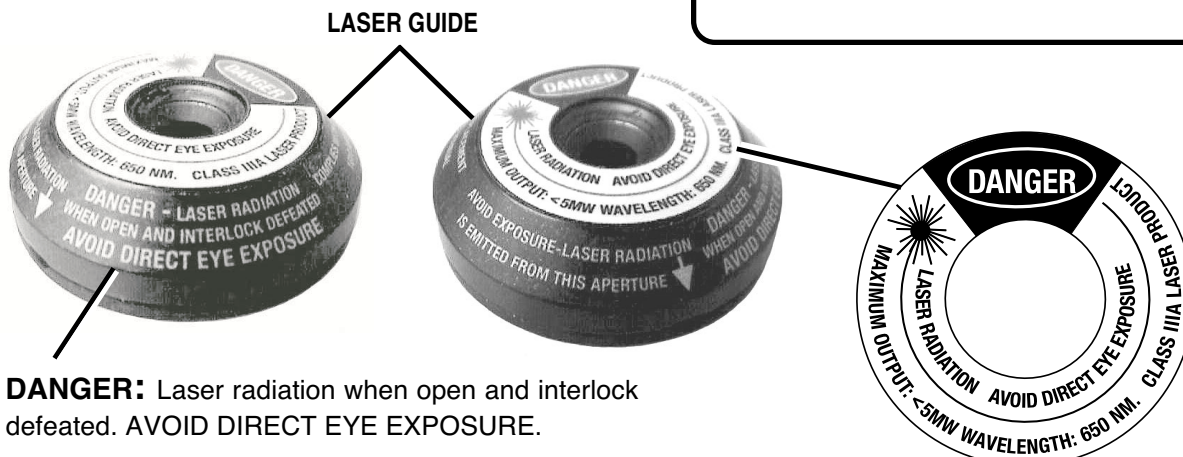

Fig. 41



**DANGER:** Laser radiation when open and interlock defeated. AVOID DIRECT EYE EXPOSURE.

# MAINTENANCE

## **WARNING:**

When servicing, use only identical Ryobi replacement parts. Use of any other part may create a hazard or cause product damage.

## **GENERAL**

Avoid using solvents when cleaning plastic parts. Most plastics are susceptible to damage from various types of commercial solvents and may be damaged by their use. Use clean cloths to remove dirt, carbon dust, etc.

## **WARNING:**

Do not at any time let brake fluids, gasoline, petroleum-based products, penetrating oils, etc. come in contact with plastic parts. They contain chemicals that can damage, weaken or destroy plastic.

## **LUBRICATION**

All of the bearings in this tool are lubricated with a sufficient amount of high grade lubricant for the life of the unit under normal operating conditions. Therefore, no further lubrication is required.

## **EXTENSION CORDS**

The use of any extension cord will cause some loss of power. To keep the loss to a minimum and to prevent tool overheating, use an extension cord that is heavy enough to carry the current the tool will draw.

A wire gage size (A.W.G.) of at least **14** is recommended for an extension cord 25 feet or less in length. When working outdoors, use an extension cord that is suitable for outdoor use. The cord's jacket will be marked WA.

## **WARNING:**

Keep extension cords away from the cutting area and position the cord so that it will not get caught on lumber, tools, etc., during cutting operation. Failure to heed this warning may result in serious personal injury.

## **CLEANING THE LASER**

It may be necessary to clean the aperture opening in the laser for best performance. To clean:

- Unplug the saw.

## **WARNING:**

Failure to unplug your saw could result in accidental starting causing possible serious personal injury.

- Remove laser from saw as shown on page 27.
- Clean the laser using a soft paintbrush or similar device to remove all sawdust and debris from the aperture.
- After cleaning, reinstall the laser as shown on page 27.

## **CAUTION:**

Check extension cords before each use. If damaged, replace immediately. Never use tool with a damaged cord since touching the damaged area could cause electrical shock resulting in serious injury.

## **WARNING:**

Always wear safety goggles or safety glasses with side shields during power tool operation or when blowing dust. If operation is dusty, also wear a dust mask.

## **WARNING:**

To ensure safety and reliability, all repairs should be performed by a qualified service technician at a Ryobi Authorized Service Center to avoid risk of personal injury.



# OPERATOR'S MANUAL

## 12 in. (305 mm) Compound Miter Saw

### Model TS1551 - Double Insulated

#### EXTENSION CORD CAUTION

When using a power tool at a considerable distance from a power source, be sure to use an extension cord that has the capacity to handle the current the tool will draw. An undersized cord will cause a drop in line voltage, resulting in overheating and loss of power. Use the chart to determine the minimum wire size required in an extension cord. Only round jacketed cords should be used.

When working with a tool outdoors, use an extension cord that is designed for outside use. This is indicated by the letters "WA" on the cord's jacket.

Before using any extension cord, inspect it for loose or exposed wires and cut or worn insulation.

\*\*Ampere rating

(on tool data plate) 0-2.0 2.1-3.4 3.5-5.0 5.1-7.0 7.1-12.0 12.1-16.0

Cord Length	Wire Size (A.W.G.)					
	0-2.0	2.1-3.4	3.5-5.0	5.1-7.0	7.1-12.0	12.1-16.0
25'	16	16	16	16	14	14
50'	16	16	16	14	14	12

**CAUTION:** Keep the extension cord clear of the working area. Position the cord so that it will not get caught on workpiece, tools, or other obstructions while you are working with a power tool.

\*\*Used on 12 gauge - 20 amp circuit.

#### • SERVICE

Now that you have purchased your tool, should a need ever exist for repair parts or service, simply contact your nearest Ryobi Authorized Service Center. Be sure to provide all pertinent facts when you call or visit. Please call 1-800-525-2579 for your nearest Ryobi Authorized Service Center. You can also check our web site at [www.ryobitools.com](http://www.ryobitools.com) for a complete list of Authorized Service Centers.

#### • MODEL NO.

The model and serial numbers of your tool will be found on a plate attached to the motor housing. Please record the serial number in the space provided below.

• MODEL NUMBER \_\_\_\_\_ TS1551 \_\_\_\_\_

• SERIAL NUMBER \_\_\_\_\_

#### RYOBI TECHNOLOGIES, INC.

1428 Pearman Dairy Road Anderson SC 29625

Post Office Box 1207 Anderson SC 29622-1207

Phone 1-800-525-2579

[www.ryobitools.com](http://www.ryobitools.com)