

RYOBI

5-1/2 in. (140 mm)

14.4 VOLT CORDLESS CIRCULAR SAW

MODEL NO. RY6202

REPAIR SHEET

RYOBI 14.4 VOLT CORDLESS CIRCULAR SAW – MODEL NUMBER RY6202

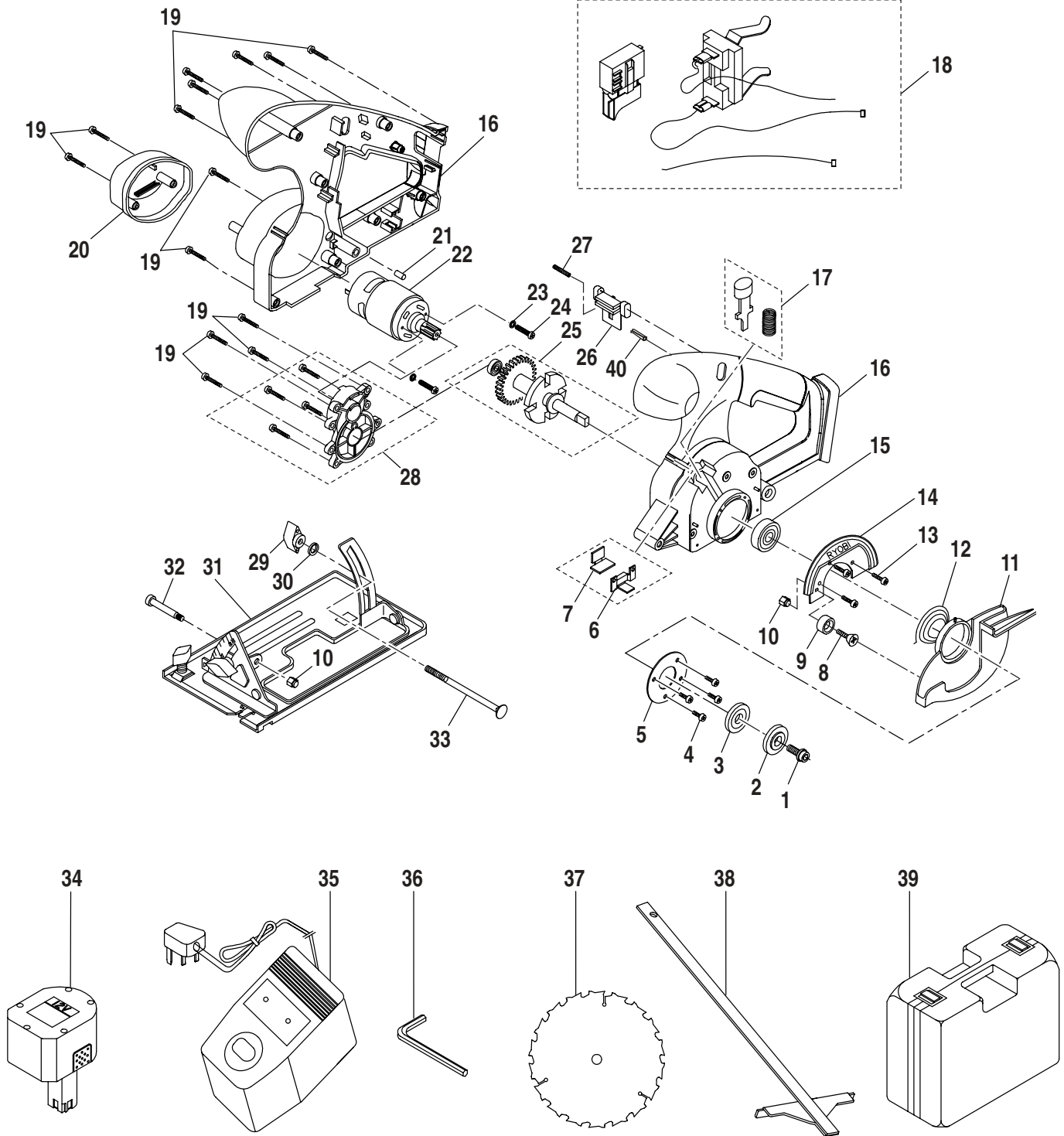

NOTE: The assembly shown represents an important part of the double insulated system. To avoid the possibility of alteration or damage to the system, service should be performed by your nearest Ryobi Authorized Service Center. For the service center nearest you call 1-800-525-2579.

RYOBI 14.4 VOLT CORDLESS CIRCULAR SAW – MODEL NUMBER RY6202

The model number will be found on a plate attached to the motor housing. Always mention the model number in all correspondence regarding your **CIRCULAR SAW** or when ordering repair parts.

PARTS LIST

Key No.	Part Number	Description	Qty.
1	6614401	* SCREW (M6 X 16 mm)	1
2	6112101	OUTER BLADE CLAMP	1
3	6112004	INNER BLADE WASHER	1
4	6600506	* BEARING RETAINER SCREW (M3 X 10 mm)	4
5	6850303	BEARING RETAINER	1
6	6322602	STEEL COVERING PLATE (0.5 mm)	1
7	9030302	SEALING PAD	1
8	6619302	BUMPER SCREW	1
9	5217802	BUMPER	1
10	6797401	LOCK NUT	2
11	5599404	LOWER GUARD	1
12	6867201	TORSION SPRING	1
13	6620501	* SCREW (M3)	3
14	6456802	UPPER BLADE GUARD	1
15	6807001	BALL BEARING	1
16	200212123	HOUSING ASSEMBLY	1
17	3033215	SHAFT LOCK	1
18	2701132	SWITCH ASSEMBLY	1
19	6620803	* SCREW (M4 X 22 mm)	14
20	5314909	END CAP	1
21	5621901	CONTACT PLATE STOPPER	1
22	2301443	MOTOR WITH PINION	1
23	6703001	SPRING WASHER	2
24	6621503	* SCREW (M4 X 16 mm)	2
25	3000339	OUTPUT SHAFT ASSEMBLY	1
26	5217310	SAFETY KNOB	1
27	6799802	SPRING	1
28	3020811	GEAR CASING ASSEMBLY	1
29	5224501	KNOB	1
30	5228001	FLAT WASHER	1
31	3025507	BASE ASSEMBLY	1
32	6614501	* SCREW (M5 X 40 mm)	1
33	6614301	BOLT	1
34	1322411	BATTERY PACK	1
35	1412001	CHARGER	1
36	6800201	HEX KEY	1
37	6797329	BLADE	1
38	6795708	EDGE GUIDE	1
39	3091227	CARRYING CASE	1
40	6763101	CARBON SPRING PIN	1
	983000-191	OPERATOR'S MANUAL	1
	983000-191R	REPAIR SHEET	1
	10-30-03		

* Standard Hardware Item – May Be Purchased Locally