



OPERATOR'S MANUAL

Random Orbit Sander

RS2418

DOUBLE INSULATED

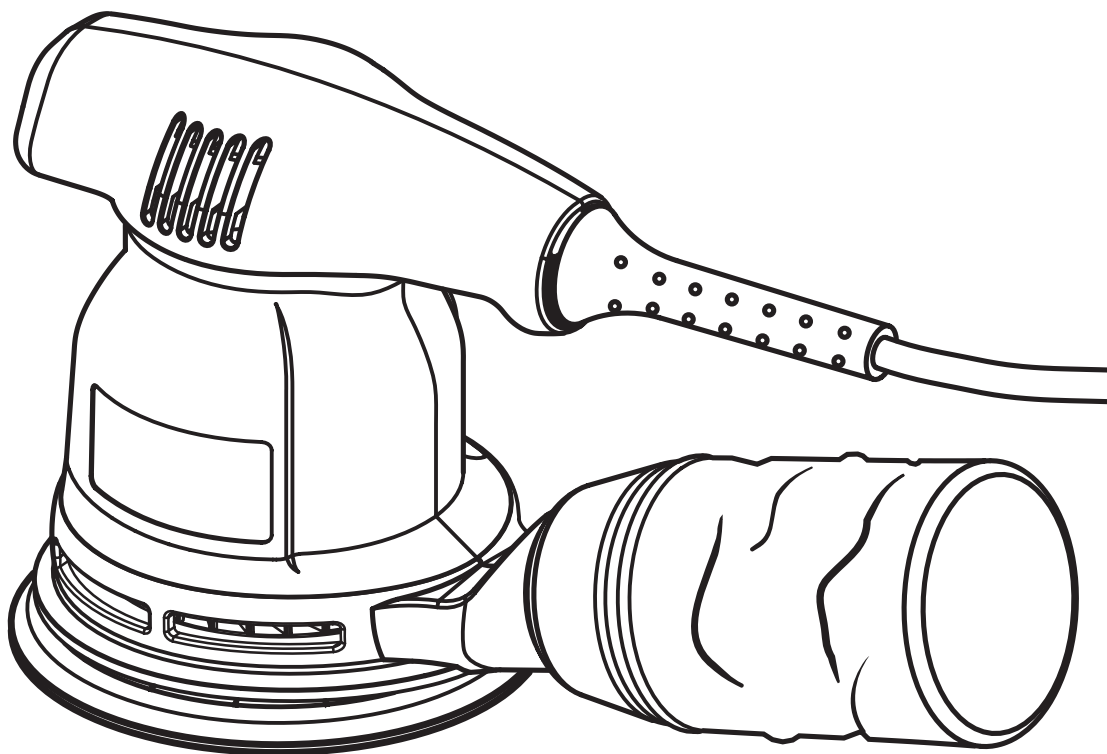

Your new tool has been engineered and manufactured to Ryobi's high standard for dependability, ease of operation, and operator safety. Properly cared for, it will give you years of rugged, trouble-free performance.

⚠ WARNING: To reduce the risk of injury, the user must read and understand the operator's manual before using this product.

Thank you for buying a Ryobi tool.

SAVE THIS MANUAL FOR FUTURE REFERENCE

TABLE OF CONTENTS

■ Introduction	2
■ General Safety Rules	3-4
■ Specific Safety Rules	4
■ Symbols	5
■ Electrical	6
■ Features	7
■ Unpacking	7
■ Assembly	8-10
■ Operation	11
■ Maintenance	12
■ Accessories	13
■ Parts Ordering / Service	14

INTRODUCTION

This tool has many features for making its use more pleasant and enjoyable. Safety, performance, and dependability have been given top priority in the design of this product making it easy to maintain and operate.

WARNING:

Do not attempt to use this product until you read thoroughly and understand completely the operator's manual. Pay close attention to the safety rules, including Dangers, Warnings, and Cautions. If you use this tool properly and only for what it is intended, you will enjoy years of safe, reliable service.

WARNING:



The operation of any sander can result in foreign objects being thrown into your eyes, which can result in severe eye damage. Before beginning power tool operation, always wear safety goggles or safety glasses with side shields and a full face shield when needed. We recommend Wide Vision Safety Mask for use over eyeglasses or standard safety glasses with side shields. Always wear eye protection which is marked to comply with ANSI Z87.1.



Look for this symbol to point out important safety precautions. It means attention!!! Your safety is involved.

GENERAL SAFETY RULES



WARNING:

Read and understand all instructions. Failure to follow all instructions listed below, may result in electric shock, fire and/or serious personal injury.

SAVE THESE INSTRUCTIONS

WORK AREA

- **Keep your work area clean and well lit.** Cluttered benches and dark areas invite accidents.
- **Do not operate power tools in explosive atmospheres, such as in the presence of flammable liquids, gases, or dust.** Power tools create sparks which may ignite the dust or fumes.
- **Keep bystanders, children, and visitors away while operating a power tool.** Distractions can cause you to lose control.

ELECTRICAL SAFETY

- **Double insulated tools are equipped with a polarized plug (one blade is wider than the other). This plug will fit in a polarized outlet only one way. If the plug does not fit fully in the outlet, reverse the plug. If it still does not fit, contact a qualified electrician to install a polarized outlet. Do not change the plug in any way.** Double insulation  eliminates the need for the three-wire grounded power cord and grounded power supply system.
- **Avoid body contact with grounded surfaces such as pipes, radiators, ranges, and refrigerators.** There is an increased risk of electric shock if your body is grounded.
- **Don't expose power tools to rain or wet conditions.** Water entering a power tool will increase the risk of electric shock.
- **Do not abuse the cord. Never use the cord to carry the tools or pull the plug from an outlet. Keep cord away from heat, oil, sharp edges, or moving parts. Replace damaged cords immediately.** Damaged cords increase the risk of electric shock.
- **When operating a power tool outside, use an outdoor extension cord marked "W-A" or "W".** These cords are rated for outdoor use and reduce the risk of electric shock.

PERSONAL SAFETY

- **Stay alert, watch what you are doing and use common sense when operating a power tool. Do not use tool while tired or under the influence of drugs, alcohol, or medication.** A moment of inattention while operating power tools may result in serious personal injury.
- **Dress properly. Do not wear loose clothing or jewelry. Contain long hair. Keep your hair, clothing, and gloves away from moving parts.** Loose clothes, jewelry, or long hair can be caught in moving parts.

- **Avoid accidental starting. Be sure switch is off before plugging in.** Carrying tools with your finger on the switch or plugging in tools that have the switch on invites accidents.
- **Remove adjusting keys or wrenches before turning the tool on.** A wrench or a key that is left attached to a rotating part of the tool may result in personal injury.
- **Do not overreach. Keep proper footing and balance at all times.** Proper footing and balance enables better control of the tool in unexpected situations.
- **Use safety equipment. Always wear eye protection.** Dust mask, nonskid safety shoes, hard hat, or hearing protection must be used for appropriate conditions.
- **Do not wear loose clothing or jewelry. Contain long hair.** Loose clothes, jewelry, or long hair can be drawn into air vents.
- **Do not use on a ladder or unstable support.** Stable footing on a solid surface enables better control of the tool in unexpected situations.

TOOL USE AND CARE

- **Use clamps or other practical way to secure and support the workpiece to a stable platform.** Holding the work by hand or against your body is unstable and may lead to loss of control.
- **Do not force tool. Use the correct tool for your application.** The correct tool will do the job better and safer at the rate for which it is designed.
- **Do not use tool if switch does not turn it on or off.** Any tool that cannot be controlled with the switch is dangerous and must be repaired.
- **Disconnect the plug from power source before making any adjustments, changing accessories, or storing the tool.** Such preventive safety measures reduce the risk of starting the tool accidentally.
- **Store idle tools out of the reach of children and other untrained persons.** Tools are dangerous in the hands of untrained users.
- **Maintain tools with care. Keep cutting tools sharp and clean.** Properly maintained tools with sharp cutting edges are less likely to bind and are easier to control.
- **Check for misalignment or binding of moving parts, breakage of parts, and any other condition that may affect the tool's operation. If damaged, have the tool serviced before using.** Many accidents are caused by poorly maintained tools.
- **Use only accessories that are recommended by the manufacturer for your model.** Accessories that may be suitable for one tool, may become hazardous when used on another tool.
- **Keep the tool and its handle dry, clean and free from oil and grease.** Always use a clean cloth when cleaning. Never use brake fluids, gasoline, petroleum-based products, or any strong solvents to clean your tool. Following this rule will reduce the risk of loss of control and deterioration of the enclosure plastic.

GENERAL SAFETY RULES

SERVICE

- **Tool service must be performed only by qualified repair personnel.** Service or maintenance performed by unqualified personnel may result in a risk of injury.
- **When servicing a tool, use only identical replacement parts. Follow instructions in the Maintenance section of this manual.** Use of unauthorized parts or failure to follow Maintenance Instructions may create a risk of shock or injury.

SPECIFIC SAFETY RULES

- **Hold tool by insulated gripping surfaces when performing an operation where the cutting tool may contact hidden wiring or its own cord.** Contact with a “live” wire will make exposed metal parts of the tool “live” and shock the operator.

Additional Rules For Safe Operation

- **Know your power tool. Read operator’s manual carefully. Learn its applications and limitations, as well as the specific potential hazards related to this tool.** Following this rule will reduce the risk of electric shock, fire, or serious injury.
- **Always wear safety glasses. Everyday eyeglasses have only impact-resistant lenses; they are NOT safety glasses.** Following this rule will reduce the risk of serious personal injury.
- **Protect your lungs. Wear a face or dust mask if the operation is dusty.** Following this rule will reduce the risk of serious personal injury.
- **Protect your hearing. Wear hearing protection during extended periods of operation.** Following this rule will reduce the risk of serious personal injury.
- **Inspect tool cords periodically and, if damaged, have repaired at your nearest authorized service center. Constantly stay aware of cord location.** Following this rule will reduce the risk of electric shock or fire.
- **Check damaged parts. Before further use of the tool, a guard or other part that is damaged should be carefully checked to determine that it will operate properly and perform its intended function. Check for alignment of moving parts, binding of moving parts, breakage of parts, mounting, and any other conditions that may affect its operation. A guard or other part that is damaged should be properly repaired or replaced by an authorized service center.** Following this rule will reduce the risk of shock, fire, or serious injury.
- **Do not abuse cord. Never carry the tool by the cord or yank it to disconnect it from the receptacle. Keep cord away from heat, oil, and sharp edges.** Following this rule will reduce the risk of electric shock or fire.
- **Make sure your extension cord is in good condition. When using an extension cord, be sure to use one heavy enough to carry the current your product will draw. A wire gage size (A.W.G.) of at least 16 is recommended for an extension cord 100 feet or less in length. A cord exceeding 100 feet is not recommended. If in doubt, use the next heavier gage. The smaller the gage number, the heavier the cord.** An undersized cord will cause a drop in line voltage resulting in loss of power and overheating.
- **Inspect for and remove all nails from lumber before sanding.** Following this rule will reduce the risk of serious personal injury.
- **Drugs, alcohol, medication. Do not operate tool while under the influence of drugs, alcohol, or any medication.** Following this rule will reduce the risk of electric shock, fire, or serious personal injury.
- **Save these instructions. Refer to them frequently and use them to instruct others who may use this tool. If you loan someone this tool, loan them these instructions also.**

WARNING:





Some dust created by power sanding, sawing, grinding, drilling, and other construction activities contains chemicals known to cause cancer, birth defects or other reproductive harm. Some examples of these chemicals are:

- lead from lead-based paints,
- crystalline silica from bricks and cement and other masonry products, and
- arsenic and chromium from chemically-treated lumber.

Your risk from these exposures varies, depending on how often you do this type of work. To reduce your exposure to these chemicals: work in a well ventilated area, and work with approved safety equipment, such as those dust masks that are specially designed to filter out microscopic particles.

SYMBOLS

Important: Some of the following symbols may be used on this tool. Please study them and learn their meaning. Proper interpretation of these symbols will allow you to operate the tool better and safer.

SYMBOL	NAME	DESIGNATION/EXPLANATION
V	Volts	Voltage
A	Amperes	Current
Hz	Hertz	Frequency (cycles per second)
W	Watt	Power
min	Minutes	Time
~	Alternating Current	Type of current
≡	Direct Current	Type or a characteristic of current
n_0	No Load Speed	Rotational speed, at no load
	Class II Construction	Double-insulated construction
.../min	Per Minute	Revolutions, strokes, surface speed, orbits etc., per minute
	Safety Alert	Precautions that involve your safety
	Read The Operator's Manual	To reduce the risk of injury, the user must read and understand the operator's manual before using this product.
	Eye Protection	Always wear safety goggles or safety glasses with side shields and a full face shield when operating this product.
	Wet Conditions Alert	Do not expose to rain or use in damp locations.

The purpose of safety symbols is to attract your attention to possible dangers. The safety symbols, and the explanations with them, deserve your careful attention and understanding. The safety warnings do not by themselves eliminate any danger. The instructions or warnings they give are not substitutes for proper accident prevention measures.

SYMBOL MEANING



DANGER: Indicates an imminently hazardous situation, which, if not avoided, will result in death or serious injury.



WARNING: Indicates a potentially hazardous situation, which, if not avoided, could result in death or serious injury.



CAUTION: Indicates a potentially hazardous situation, which, if not avoided, may result in minor or moderate injury. It may also be used to alert against unsafe practices that may cause property damage.

Note:

Advises you of additional information concerning the operation or maintenance of the equipment.

ELECTRICAL

DOUBLE INSULATION

Double insulation is a concept in safety in electric power tools, which eliminates the need for the usual three-wire grounded power cord. All exposed metal parts are isolated from the internal metal motor components with protecting insulation. Double insulated tools do not need to be grounded.

WARNING:

The double insulated system is intended to protect the user from shock resulting from a break in the tool's internal insulation. Observe all normal safety precautions to avoid electrical shock.

Important: Servicing of a tool with double insulation requires extreme care and knowledge of the system and should be performed only by a qualified service technician. For service, we suggest you return the tool to your nearest authorized service center for repair. Always use only original factory replacement parts when servicing.

ELECTRICAL CONNECTION

This tool has a precision-built electric motor. **It should be connected to a power supply that is 120 volts, 60 Hz, AC only (normal household current).** Do not operate this tool on direct current (DC). A substantial voltage drop will cause a loss of power and the motor will overheat. If your tool does not operate when plugged into an outlet, double-check the power supply.

IMPORTANT

Servicing of a tool with double insulation requires extreme care and knowledge of the system and should be performed only by a qualified service technician. For service we suggest you return the tool to your nearest **RYOBI AUTHORIZED SERVICE CENTER** for repair. When servicing use only identical Ryobi replacement parts.

EXTENSION CORDS

When using a power tool at a considerable distance from a power source, be sure to use an extension cord that has the capacity to handle the current the tool will draw. An undersized cord will cause a drop in line voltage, resulting in overheating and loss of power. Use the chart to determine the minimum wire size required in an extension cord. Only round jacketed cords listed by Underwriter's Laboratories (UL) should be used.

When working outdoors with a tool, use an extension cord that is designed for outside use. This type of cord is designated with "WA" on the cord's jacket.

Before using any extension cord, inspect it for loose or exposed wires and cut or worn insulation.

**Ampere rating
(on tool faceplate) 0-2.0 2.1-3.4 3.5-5.0 5.1-7.0 7.1-12.0 12.1-16.0

Cord Length	Wire Size (A.W.G.)					
25'	16	16	16	16	14	14
50'	16	16	16	14	14	12
100'	16	16	14	12	10	—

***Used on 12 gage - 20 amp circuit.*

WARNING:

Keep the extension cord clear of the working area. Position the cord so that it will not become entangled in the rotating foam pad or caught on lumber, tools or other obstructions while you are working with the tool. Failure to do so can result in serious personal injury.

WARNING:

Check extension cords before each use. If damaged replace immediately. Never use tool with a damaged cord since touching the damaged area could cause electrical shock resulting in serious injury.

FEATURES

SPECIFICATIONS

Sanding Pad Length	5 in. (127 mm)
No Load Speed	12,500/min.
Diameter of orbit	3/32 in. (2.5 mm)
Rating	120 Volts, 60 Hz, AC, 2.4 Amperes
Net Weight	2.75 lbs. (1.25 kg.)

KNOW YOUR SANDER

See Figure 1.

Before attempting to use your sander, familiarize yourself with all operating features and safety requirements.

SWITCH

This tool is equipped with a simple on/off switch control. (To turn your sander **ON**, depress the switch button as shown in Figure 1. Depress the switch button in the opposite direction to turn your sander **OFF**).

The sander has a comfortable palm grip that provides easy handling and positive control and is suitable for sanding with coarse, medium, and fine grit sanding disc.

CONVERSION PAD

Converts the standard sanding pad from use with pressure sensitive sanding discs for use with velcro type sanding discs.

RANDOM ORBIT

The random orbit motion provides overlapping sanding movements by combining orbital and turning motion. These overlapping sanding movements provide fast cutting action with excellent sanding results.

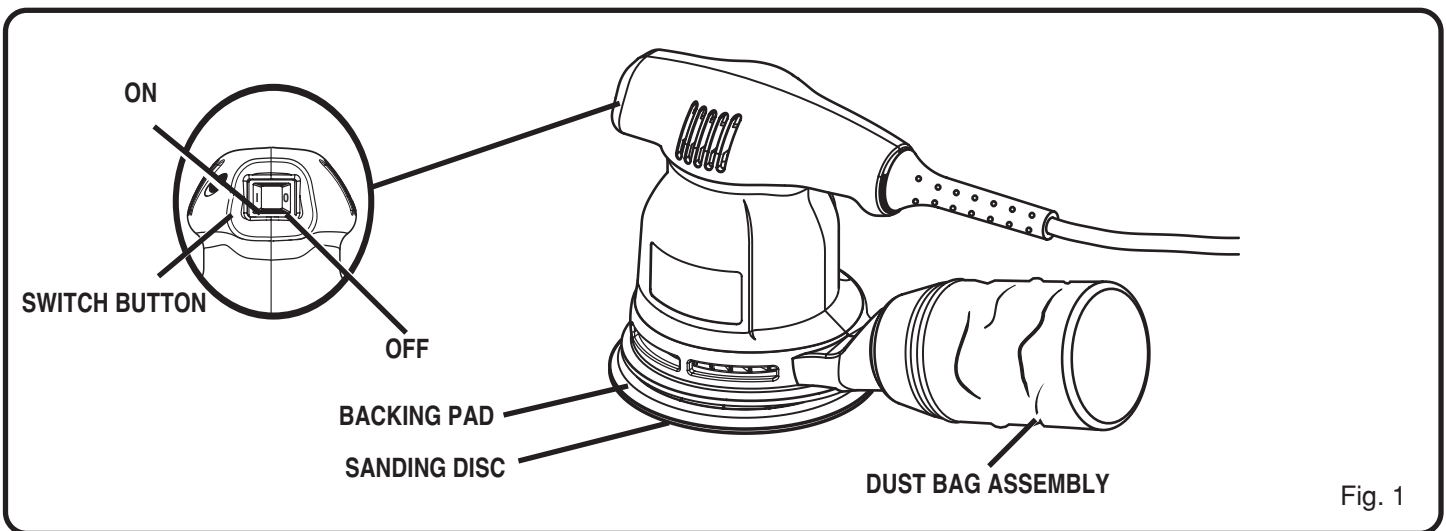

UNPACKING

- Carefully remove the sander, and accessories from box. Make sure all items listed in the Packing List are included.
- Do not discard the packing material until you have carefully inspected and satisfactorily operated sander.
- Examine all parts and accessories to make sure that no breakage has occurred during shipping. Any damaged part should be replaced before attempting to use the tool.
- If any parts are damaged or missing, please call 1-800-525-2579 for assistance.

PACKING LIST

- Sanding Disc (3)
- Conversion Pad (for velcro type sanding discs)
- Dust Bag Assembly
- Warranty Card
- Operator's Manual

⚠ WARNING:

If any parts are missing do not operate your tool until the missing parts are replaced. Failure to do so could result in possible serious personal injury.

ASSEMBLY

The backing pad on your sander provides the capability to use sanding discs with pressure sensitive adhesive backing material. You also receive a conversion pad which allows use of sanding discs with velcro type backing material.

SANDING DISC SELECTION

Selecting the correct size grit and type sanding disc is an extremely important step in achieving a high quality sanded finish. Aluminum oxide, silicon carbide, and other synthetic abrasives are best for power sanding. Natural abrasives, such as flint and garnet are too soft for economical use in power sanding.

In general, coarse grit will remove the most material and finer grit will produce the best finish in all sanding operations. The condition of the surface to be sanded will determine which grit will do the job. If the surface is rough, start with a coarse grit and sand until the surface is uniform. Medium grit may then be used to remove scratches left by the coarser grit and finer grit used for finishing of the surface. Always continue sanding with each grit until surface is uniform.



WARNING:

The tool should never be connected to power supply when you are assembling parts, making adjustments, assembling or replacing sanding disc, cleaning, or when not in use. Disconnecting your sander can prevent accidental starting that could cause serious personal injury.

TO ATTACH PRESSURE SENSITIVE ADHESIVE SANDING DISC

See Figure 2.

- Unplug your sander.
- Carefully peel paper backing from the pressure sensitive adhesive type sanding disc.
- Align holes in sanding disc with holes in backing pad, then carefully press sticky side of disc against pad as tight as possible.

NOTE: Holes in sanding disc must line up with holes in the backing pad in order for the dustless feature of your sander to function properly.

NOTE: It is recommended that you clean backing pad occasionally by brushing lightly with a small brush. Dust buildup on backing pad could cause sanding disc not to stick properly.

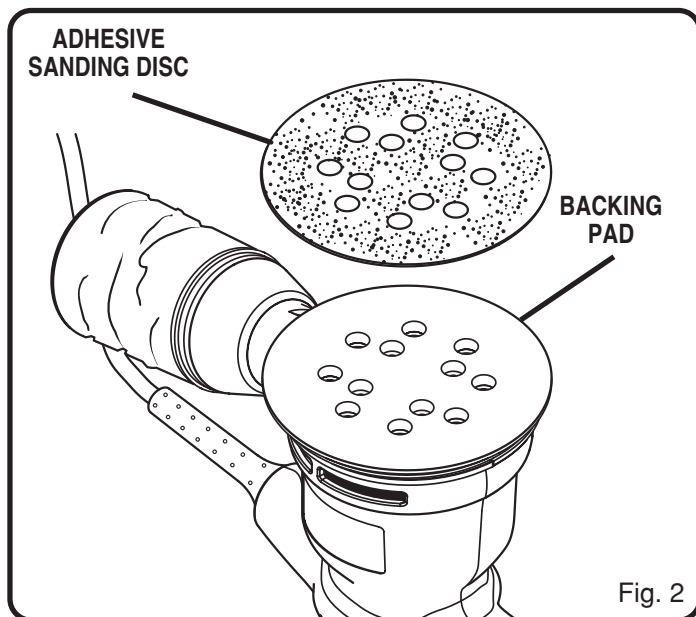

REMOVING SANDING DISC BEFORE STORAGE

Do not store your sander with the sanding disc installed. Heat generated from sanding causes the pressure sensitive adhesive to flow and form a tight bond between the backing pad and sanding disc.

Removing the sanding disc soon after you have finished a sanding operation avoids letting the adhesive set up. If the sanding disc is left on the backing pad for an extended period of time after use, the adhesive will set up and cause the sanding disc to become difficult to remove.

It may also tear when removing. When this situation occurs, it becomes difficult to clean the backing pad for the next sanding disc.

NOTE: If you forget to remove the sanding disc after a sanding operation, sand for a few minutes to soften the adhesive backing before attempting to remove sanding disc.

ASSEMBLY

TO ATTACH CONVERSION PAD AND VELCRO TYPE SANDING DISC

The conversion pad provided with your sander has a pressure sensitive adhesive backing material. It is applied by the same method as pressure sensitive adhesive paper.

- Unplug your sander.
- Carefully peel paper backing from the conversion pad and align with holes in backing pad. Firmly press sticky side of conversion pad against backing pad. Your sander is now ready to use velcro type sanding discs.
- Align holes in velcro type sanding disc with holes in conversion pad, then carefully press fuzzy side of sanding disc against pad as tight as possible.

NOTE: Velcro type sanding discs can be reused for the life of the sanding abrasive. It is recommended that you keep the sanding disc backing and the conversion pad clean to provide the best attachment. Clean occasionally by brushing lightly with a small brush.

DUSTLESS SANDING

See Figures 3 and 4.

The dust bag assembly provides a dust collection system for your sander. It can be installed by slipping it over the blower exhaust with a twisting motion. Sanding dust is drawn up through the holes of the sanding disc to collect in the dust bag during sanding operation.

NOTE: For more efficient operation, empty dust bag when no more than half full. This will permit the air to flow through the bag better.

WARNING:

To prevent the possibility of sanding dust or foreign objects being thrown into your face or eyes, never attempt to use your sander without the dust bag properly installed. Sanding dust or foreign objects being thrown into your face can result in possible serious personal injury.

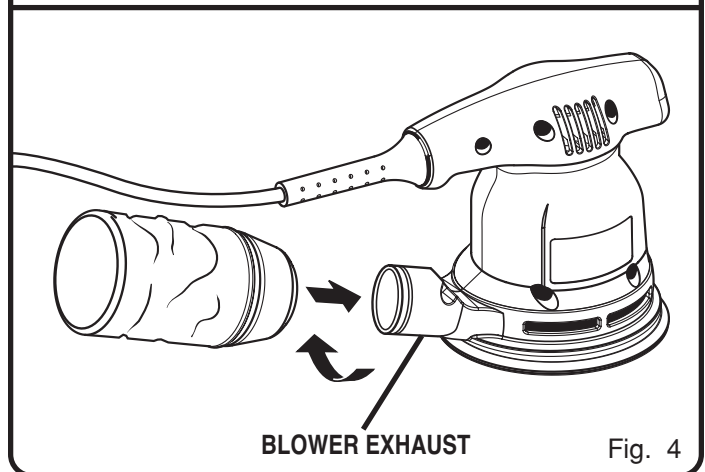
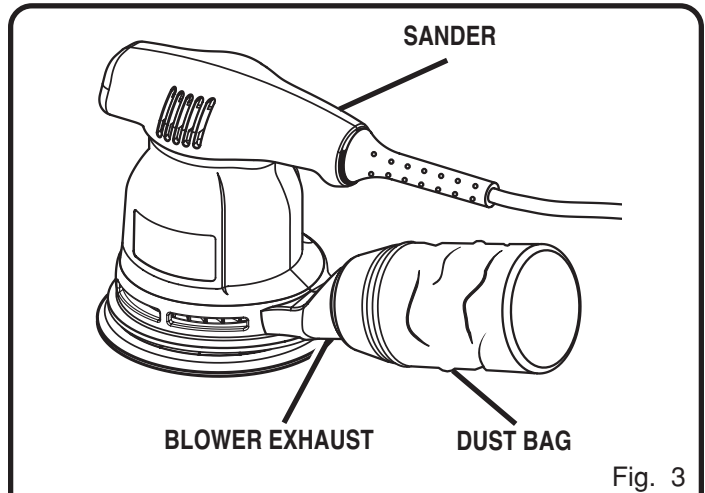

ASSEMBLY

ATTACHING SANDER TO VACUUM

When sanding for an extended period of time, you can easily attach the dust collection system of your sander to a vacuum.

TO ATTACH:

See Figure 5.

- Unplug your sander.
- Remove dust bag from sander.
- Attach vacuum hose to blower exhaust as shown in Figure 5.
NOTE: Vacuum hose fits inside blower exhaust.
- Connect sander and vacuum to power supply.

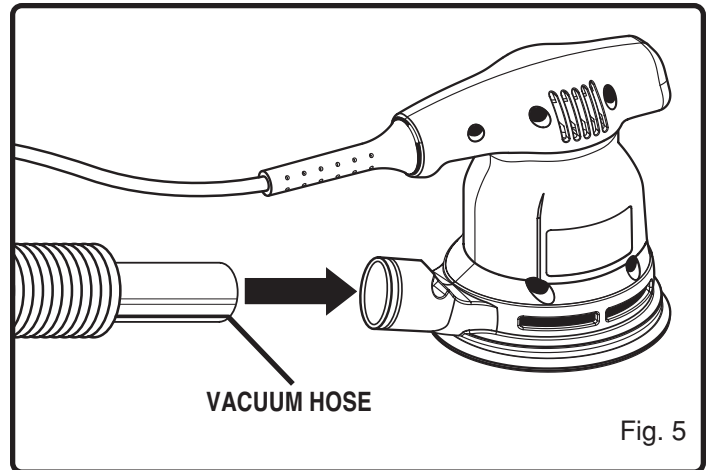

⚠ WARNING:

When sander is not connected to vacuum, always install dust bag back on sander. Failure to do so can cause sanding dust or foreign objects to be thrown into your face or eyes which could result in possible serious injury.

⚠ WARNING:

Do not use this product as a component of other products. Also, do not use attachments or accessories not recommended for use with this product. Any such use can result in possible serious personal injury.

⚠ CAUTION:

To ensure proper brake operation after extended use, periodically check its operation by removing the sanding disc and running your sander without load (off the workpiece). The backing pad should not take longer than 6 seconds to stop. If it takes longer than 6 seconds to stop, return the sander to your nearest **RYOBI AUTHORIZED SERVICE CENTER** for repair.

⚠ WARNING:

Do not wear loose clothing or jewelry when operating sander. They could get caught in moving parts causing serious injury. Keep head away from sander and sanding area. Hair could be drawn into sander causing serious injury.

⚠ WARNING:

Before connecting your sander to power supply source, always check to be sure the switch is not in **ON** position. Failure to do so can result in accidental starting of your sander resulting in possible serious injury.

⚠ WARNING:

Do not allow familiarity with your sander to make you careless. Remember that a careless fraction of a second is sufficient to inflict severe injury.

OPERATION

CAUTION:

To avoid damaging the motor from overheating, Be careful not to let your hand cover the air vents.

APPLICATIONS

(Use only for the purposes listed below)

- Sanding on wood surfaces.
- Removing rust from and sanding steel surfaces.

TURNING THE SANDER ON/OFF

To turn the sander **ON**, depress the switch button as shown in Figure 1. Depress the switch button in the opposite direction to turn the sander **OFF**.

SANDING

See Figures 6 and 7.

Clamp or otherwise secure the work to prevent it from moving under your sander.

WARNING:

Unsecured workpieces can be thrown towards the operator causing injury.

Place sander on workpiece so that all of sanding disc surface is in contact with workpiece. Start your sander and move it slowly over workpiece making successive passes in parallel lines, circles, or crosswise movements. Upon completion of sanding operation, turn sander off and wait until sanding disc comes to a complete stop before removing from workpiece.

DO NOT FORCE. The weight of the unit supplies adequate pressure, so let the sanding disc and sander do the work. Applying additional pressure only slows the motor, rapidly wears sanding disc and greatly reduces sander speed. Excessive pressure will overload the motor causing possible damage from motor overheating and can result in inferior work. Any finish or resin on wood may soften from the frictional heat. Do not allow sanding on one spot too long as the sander's rapid action may remove too much material, making the surface uneven.

Extended periods of sanding may tend to overheat the motor. If this occurs, turn sander off and wait until sanding disc comes to a complete stop, then remove it from workpiece. Remove your hand from vent area, remove sanding disc, then with your hand removed from vent area, turn sander on and run it free without a load to cool motor.

Flush sanding can be performed with your sander. As shown in Figure 7, the front edge of your sander allows flush sanding. Upon completion of sanding operation, turn sander off and wait until sanding disc comes to a complete stop before removing from workpiece.

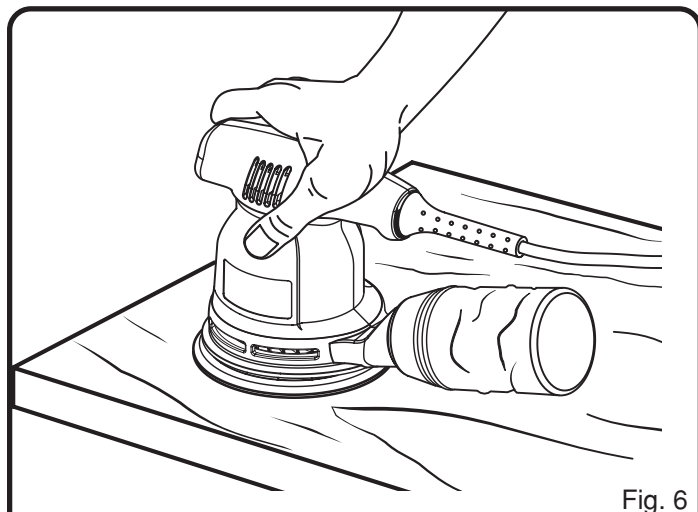

Fig. 6

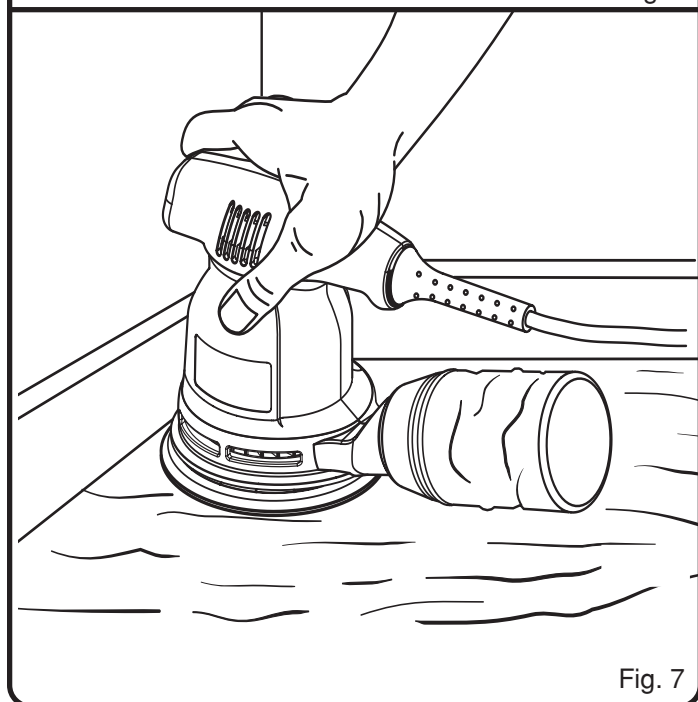

Fig. 7

MAINTENANCE

⚠ WARNING:

When servicing use only identical Ryobi replacement parts. Use of any other parts can create a hazard or cause product damage.

⚠ WARNING:

The tool should never be connected to power supply when you are assembling parts, making adjustments, assembling or replacing sanding disc, cleaning, or when not in use. Disconnecting your sander can prevent accidental starting that could cause serious personal injury.

CLEANING DUST BAG ASSEMBLY

See Figures 8 and 9.

As previously mentioned, for more efficient operation, empty dust bag when no more than half full. This will permit the air to flow through the bag better.

⚠ WARNING:

Collected sanding dust from sanding surface coatings such as polyurethanes, linseed oil, etc., can self ignite in your sander dust bag or elsewhere and cause fire. To reduce the risk of fire always empty your dust bag frequently while sanding and never store or leave a sander without totally emptying its dust bag. Also follow the recommendations of the coatings manufacturers.

TO EMPTY DUST BAG:

- Unplug your sander.
- Remove dust bag from sander and shake out dust. See Figure 8.
- For a more thorough cleaning of the dust bag, remove dust bag from frame, as shown in figure 9, and shake out dust.
- Replace dust bag over frame then install dust bag on sander.

GENERAL

Avoid using solvents when cleaning plastic parts. Most plastics are susceptible to damage from various types of commercial solvents and may be damaged by their use. Use clean cloths to remove dirt, carbon dust, etc.

When electric tools are used on fiberglass boats, sports cars, wallboard, spackling compounds, or plaster, it has been found that they are subject to accelerated wear and possible premature failure, as the fiberglass chips and grindings are highly abrasive to bearings, brushes, commutators, etc. Consequently, it is not recommended that this tool be used for extended work on any fiberglass material, wallboard, spackling compounds, or plaster. During any use on fiberglass it is extremely important that the tool is cleaned frequently by blowing with an air jet.

⚠ WARNING:

Do not at any time let brake fluids, gasoline, petroleum-based products, penetrating oils, etc. come in contact with plastic parts. They contain chemicals that can damage, weaken, or destroy plastic.

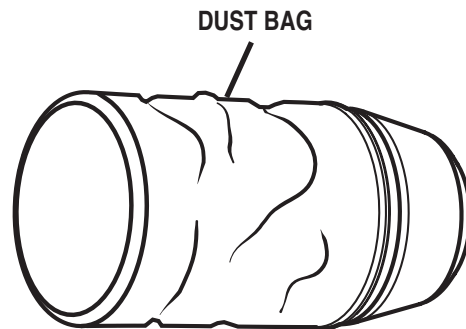

Fig. 8

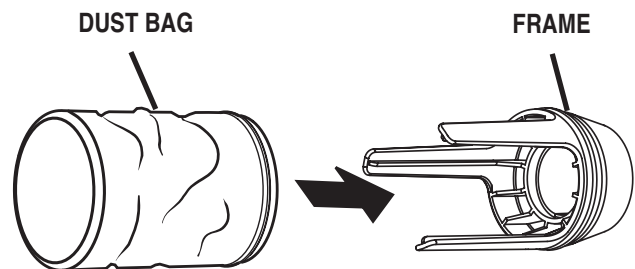

Fig. 9

⚠ WARNING:

Always wear safety goggles or safety glasses with side shields during power tool operation or when blowing dust. If operation is dusty, also wear a dust mask.

LUBRICATION

All of the bearings in this tool are lubricated with a sufficient amount of high grade lubricant for the life of the unit under normal operating conditions. Therefore, no further lubrication is required.

ACCESSORIES

The following recommended accessories are current and were available at the time this manual was printed:

4601500	15 Grit Sanding Disc	5 Per Pack	4600150	150 Grit Sanding Disc	5 Per Pack
4600040	40 Grit Sanding Disc	5 Per Pack	4600220	220 Grit Sanding Disc	5 Per Pack
4600060	60 Grit Sanding Disc	5 Per Pack	4600320	320 Grit Sanding Disc	5 Per Pack
4600080	80 Grit Sanding Disc	5 Per Pack	4600600	600 Grit Sanding Disc	5 Per Pack
4600100	100 Grit Sanding Disc	5 Per Pack	4600503	Conversion Pad	2 Per Pack

All individual sanding grits are available in handy five sheet packs.



OPERATOR'S MANUAL

Random Orbit Sander

RS2418

Double Insulated

- **SERVICE**

Now that you have purchased your tool, should a need ever exist for repair parts or service, simply contact your nearest Ryobi Authorized Service Center. Be sure to provide all pertinent facts when you call or visit. Please call 1-800-525-2579 for your nearest Ryobi Authorized Service Center. You can also check our web site at www.ryobitools.com for a complete list of Authorized Service Centers.

- **MODEL NO. AND SERIAL NO.**

The model number and serial number of this tool will be found on a plate attached to the motor housing.

Please record the serial number in the space provided below.

- MODEL NUMBER RS2418
- SERIAL NUMBER _____

Ryobi Technologies Inc.

1428 Pearman Dairy Road Anderson, SC 29625
Post Office Box 1207 Anderson, SC 29622-1207
Phone 1-800-525-2579
www.ryobitools.com