

RYOBI

**VARIABLE SPEED
RECIPROCATING SAW**

MODEL NO. RJ161V

REPAIR SHEET

RYOBI RECIPROCATING SAW – MODEL NUMBER RJ161V

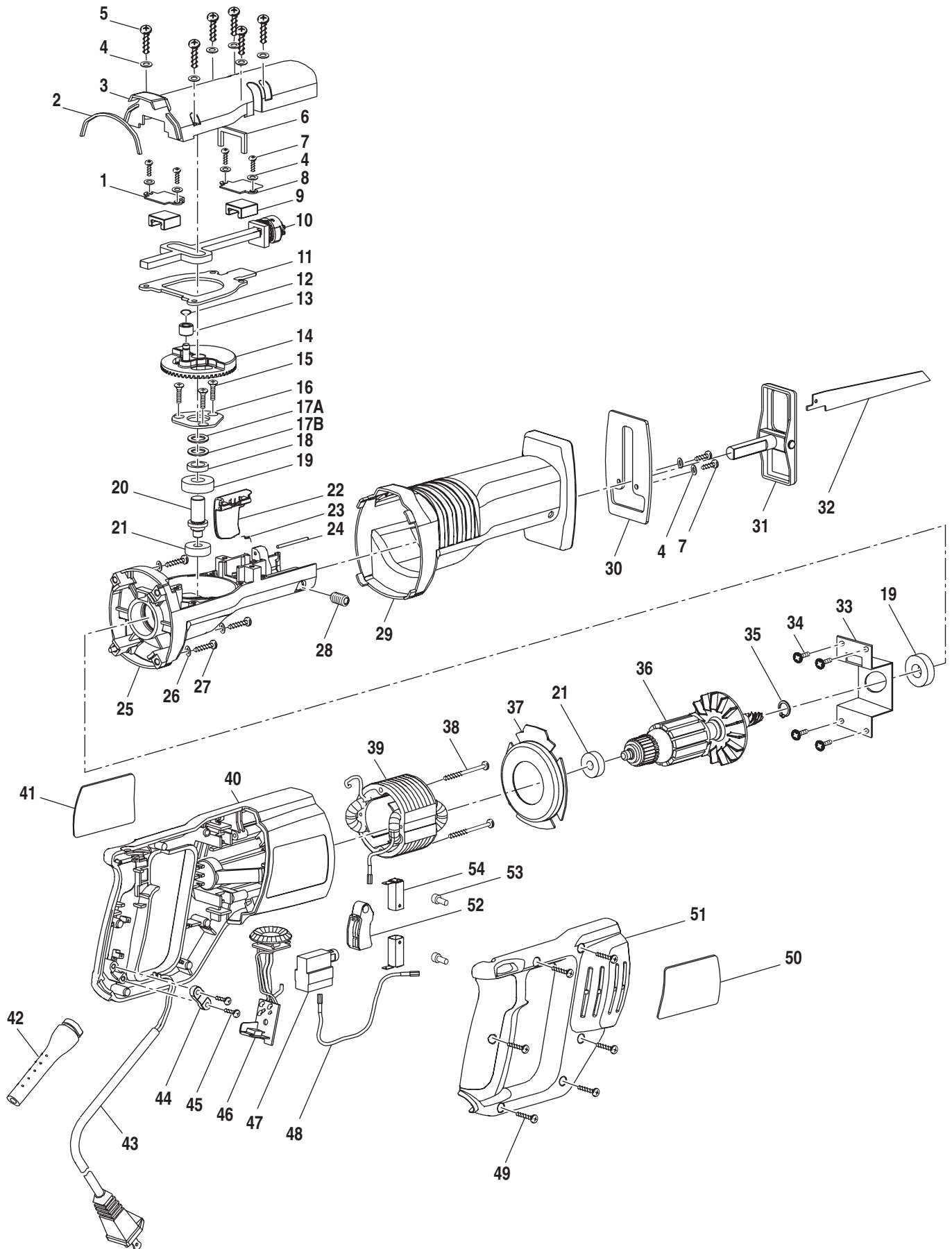

RYOBI RECIPROCATING SAW – MODEL NUMBER RJ161V

The model number will be found on a plate attached to the motor housing. Always mention the model number in all correspondence regarding your **Reciprocating Saw** or when ordering repair parts.

PARTS LIST

KEY PART NO. NUMBER	DESCRIPTION	QTY.	KEY PART NO. NUMBER	DESCRIPTION	QTY.		
1	6934201	COVER PLATE (1)	1	30	6942301	GUARD PLATE	1
2	9066701	GEAR CASE SEAL	1	31	300216014	SHOE ASSEMBLY (BEFORE G034325751)	1
3	5909501	GEAR CASE COVER	1		3021607	SHOE ASSEMBLY (AFTER G034325751)	1
4	6703001	SPRING WASHER	12	32	6934701	SAW BLADE (6 in.)	1
5	6616503	* SCREW (M4 X 18 mm)	6		6934801	SAW BLADE (4 in.)	1
6	5682601	SEAL	1	33	6950301	BEARING RETAINER	1
7	6621202	* SCREW (M4 X 10 mm)	6	34	6622801	* FLAT HEAD SCREW (M3 X 8 mm)	4
8	6934901	COVER PLATE (2)	1	35	6939601	RETAINING RING	1
9	6935601	GUIDE BLOCK	2	36	7436901	ARMATURE	1
10	3000330	SAW BAR ASSEMBLY	1	37	5909001	BAFFLE	1
11	6934501	YOKE PLATE	1	38	6615601	SCREW (SELF TAPPING)	2
12	6770401	RETAINING RING	1	39	7437001	FIELD	1
13	6829601	ROLLER BEARING	1	40	5908901	SUPPORT HOUSING	1
14	3036203	GEAR ASSEMBLY	1	41	9429807	LOGO PLATE	1
15	6621301	* SCREW (M4 X 16 mm)	3	42	5629001	BEND RELIEF	1
16	6839502	SHAFT MOUNTING PLATE	1	43	7320112	POWER CORD	1
17A	6368803	WASHER	1	44	5909301	CORD CLAMP	1
17B	6368804	WASHER	1	45	6620805	* SCREW (M4 X 16 mm)	2
18	6842301	SLEEVE	1	46	2800855	SPEED CONTROL BOARD	1
19	6939501	BALL BEARING (6001ZZ)	2	47	7615501	SWITCH (DEFOND)	1
20	6940401	GEAR SHAFT	1		7628601	SWITCH (BAICHENG)	1
21	6814104	BALL BEARING (608ZZ)	2	48	2913301	LEAD ASSEMBLY	1
22	4009401	BLADE RELEASE LEVER	1	49	6620802	SCREW (SELF TAPPING)	6
23	6950201	SPRING	1	50	9429808	DATA PLATE	1
24	6951801	PIN	1	51	5908801	COVER HOUSING	1
25	640535003	GEAR CASE (BEFORE G034325751)	1	52	5909201	TRIGGER	1
	6453501	GEAR CASE (AFTER G034325751)	1	53	5678601	RUBBER PLUG	2
26	6886301	LOCK WASHER (M5)	4	54	290069077	BRUSH TUBE ASSEMBLY	2
27	6625902	SCREW (SELF TAPPING)	4	55	300636030	CARRYING CASE (NOT SHOWN)	1
28	6617001	* SCREW (M10 X 10 mm) (BEFORE G034325751)	1		983000131	OPERATOR'S MANUAL	
	6616926	* SCREW (M6 X 14 mm) (AFTER G034325751)	1		983000131R	REPAIR SHEET (REV:01)	
29	5909101	RUBBER BOOT	1		5-10-05		

WARNING: Improper repair of a double insulated tool can result in damage to the double insulation system possibly causing electrical shock or electrocution. Any repairs requiring disassembly of your tool requires safety testing and should only be performed by a Ryobi Authorized Service Center. For the service center nearest you call 1-800-525-2579.

* Standard Hardware Item – May Be Purchased Locally