

RYOBI RECIPROCATING SAW – MODEL NUMBER RJ160V

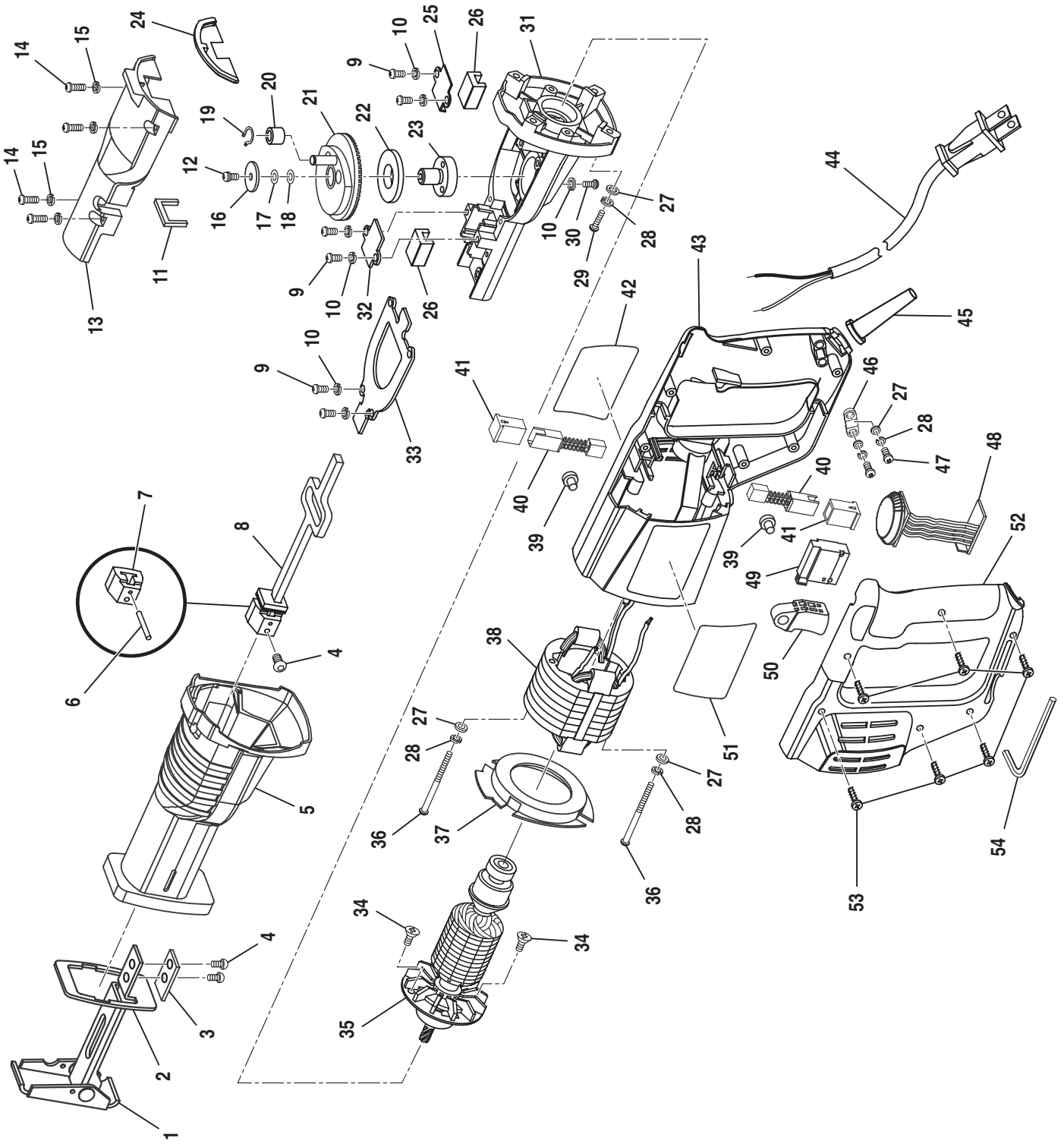

RYOBI RECIPROCATING SAW – MODEL NUMBER RJ160V

The model number will be found on a plate attached to the motor housing. Always mention the model number in all correspondence regarding your **RECIPROCATING SAW** or when ordering repair parts.

PARTS LIST

Key No.	Part Number	Description	Quan.	Key No.	Part Number	Description	Quan.
1	RJ160-16	BASE ASSEMBLY	1	30	RJ160-40	SCREW (M5 X 14 mm)	3
2	RJ160-17	BASE PLATE	1	31	RJ160-41	GEAR CASE	1
3	RJ160-69	INSULATOR	1	32	RJ160-24	FRONT BEARING BLOCK COVER	1
4	RJ160-15	SCREW (M5 X 10 mm)	3	33	RJ160-30	RETAINING COVER	1
5	RJ160-18	RUBBER BOOT	1	34	RJ160-51	SCREW (M4 X 12 mm FLAT HD.)	2
6	RJ160-67	ROLL PIN	1	35	RJ160-49	ARMATURE ASSEMBLY	1
7	RJ160-68	BLADE CLAMP	1	36	RJ160-47	SCREW (M4 X 55 mm)	2
8	RJ160-29	SAW BAR ASSEMBLY	1	37	RJ160-46	BAFFLE	1
9	RJ160-26	SCREW (M5 X 10 mm)	6	38	RJ160-48	FIELD	1
10	RJ160-25	LOCK WASHER (M5)	9	39	RJ160-14	RUBBER PLUG	2
11	RJ160-23	RUBBER SEAL	1	40	RJ160-13	BRUSH ASSEMBLY	2
12	RJ160-31	SCREW (M5 X 10 mm)	1	41	RJ160-12	BRUSH HOLDER	2
13	RJ160-19	GEAR CASE COVER	1	42	RJ160-44	LOGO LABEL	1
14	RJ160-22	SCREW (M4 X 20 mm)	4	43	RJ160-01	MOTOR HOUSING WITH HANDLE	1
15	RJ160-21	LOCK WASHER (M4)	4	44	RJ160-08	POWER CORD	1
16	RJ160-32	FLAT WASHER	1	45	RJ160-07	BEND RELIEF	1
17	RJ160-33	SHIM (THIN)	as needed	46	RJ160-03	CORD CLAMP	1
18	RJ160-34	SHIM (THICK)	as needed	47	RJ160-06	SCREW (M4 X 12 mm)	2
19	RJ160-36	RETRAINING RING	1	48	RJ160-11	SPEED CONTROL ASSEMBLY	1
20	RJ160-37	CROSS SLIDE ROLLER	1	49	RJ160-09	SWITCH	1
21	RJ160-35	BEVEL GEAR ASSEMBLY	1	50	RJ160-10	TRIGGER	1
22	RJ160-38	WASHER	1	51	RJ160-45	DATA LABEL	1
23	RJ160-39	SPINDLE	1	52	RJ160-43	HANDLE COVER	1
24	RJ160-20	GREASE SEAL	1	53	RJ160-02	SCREW (M4.2 X 18 mm)	6
25	RJ160-28	REAR BEARING BLOCK COVER	1	54	RJ160-54	HEX KEY (3 mm)	1
26	RJ160-27	BEARING BLOCK	2	55	RJ160-52	6 in. WOOD CUTTING BLADE (NOT SHOWN)	1
27	RJ160-05	FLAT WASHER (M4)	8	56	RJ160-53	4 in. METAL CUTTING BLADE (NOT SHOWN)	1
28	RJ160-04	LOCK WASHER (M4)			972000-945	OWNER'S MANUAL	
29	RJ160-42	SCREW (M4 X 28 mm)	4		9-24-03		

⚠ WARNING:

Improper repair of a double insulated tool can result in damages to the double insulation system possibly causing electrical shock or electrocution. Any repairs requiring disassembly of your tool requires safety testing and should only be performed by a **Ryobi Authorized Service Center**.