



OWNER'S OPERATING MANUAL

Electronic Plunge Router

Heavy Duty Model RE601

Variable Speed / Double Insulated

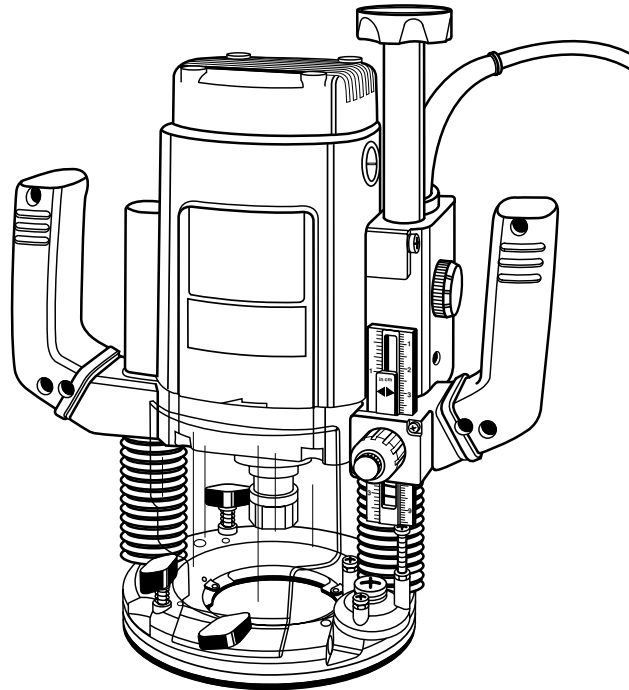

SPECIFICATIONS:

Depth Of Plunge Cut	0 - 2-3/8 in. (0 - 60.3 mm)
Maximum Cutter Diameter	2-3/8 in. (60.3 mm)
Collet	1/2 in. (13 mm)
Bit Adapter Included With Packaging	1/4 in. (6.4 mm)
Amperes / Horsepower	15 Amperes / 3 Hp
Rating	120 Volts, 60 Hz, AC Only
No Load Speed	10,000 - 22,000 RPM
Power Cord	10 ft. (3 m)
Net Weight	15.5 lbs. (7.05 kg.)

THANK YOU FOR BUYING A RYOBI ROUTER.

Your new router has been engineered and manufactured to Ryobi's high standard for dependability, ease of operation, and operator safety. Properly cared for, it will give you years of rugged, trouble-free performance.

⚠ CAUTION: Carefully read through this entire owner's manual before using your new router.

Pay close attention to the Rules for Safe Operation, Warnings, and Cautions. If you use your router properly and only for what it is intended, you will enjoy years of safe, reliable service.

Please fill out and return the Warranty Service Registration Card so we can be of future service to you.

Thank you again for buying Ryobi tools.

SAVE THIS MANUAL FOR FUTURE REFERENCE

TABLE OF CONTENTS

- Product Specifications 1
- Typical Applications 2
- Rules For Safe Operation 3-5
- Unpacking 6
- Features 6-8
- Adjustments 9-13
- Operation 14-19
- Maintenance 20-22
- Optional Accessories 22
- Parts Ordering / Service 24

TYPICAL APPLICATIONS

RE601 PLUNGE ROUTER

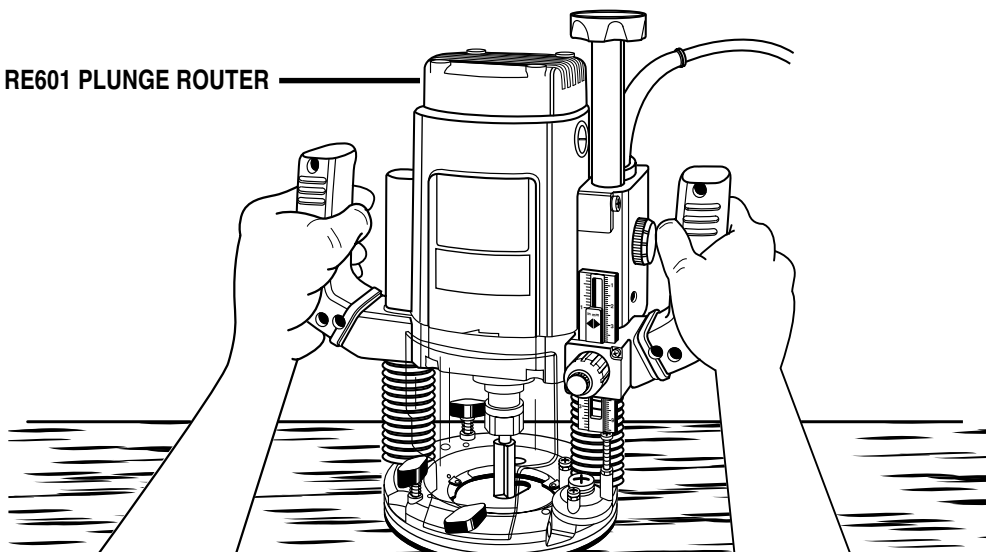

ROUTING A GROOVE, WITH A GUIDE

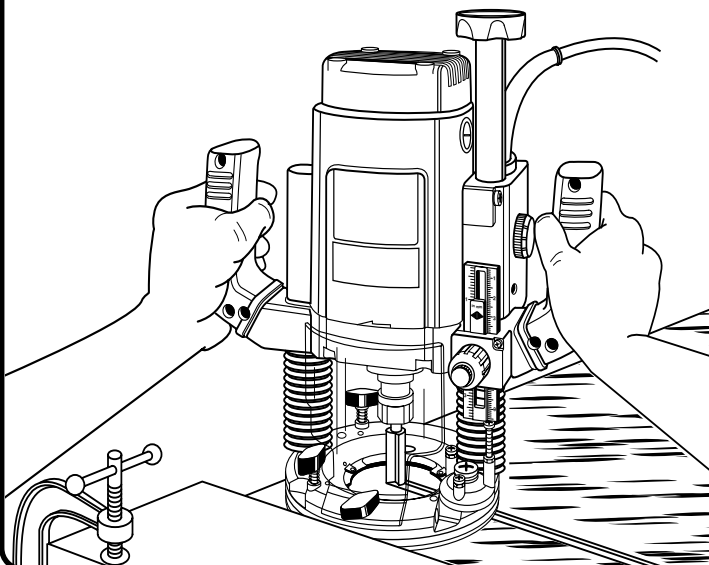

FREEHAND ROUTING

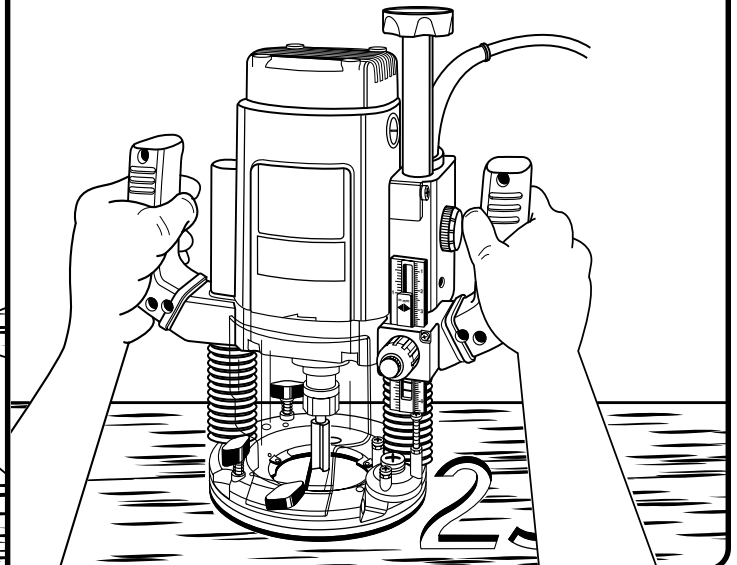

RULES FOR SAFE OPERATION

The purpose of safety symbols is to attract your attention to possible dangers. The safety symbols, and the explanations with them, deserve your careful attention and understanding. The safety warnings do not by themselves eliminate any danger. The instructions or warnings they give are not substitutes for proper accident prevention measures.

SYMBOL	MEANING
	SAFETY ALERT SYMBOL: Indicates caution or warning. May be used in conjunction with other symbols or pictographs.
	DANGER: Failure to obey a safety warning will result in serious injury to yourself or to others. Always follow the safety precautions to reduce the risk of fire, electric shock and personal injury.
	WARNING: Failure to obey a safety warning can result in serious injury to yourself or to others. Always follow the safety precautions to reduce the risk of fire, electric shock and personal injury.
	CAUTION: Failure to obey a safety warning may result in property damage or personal injury to yourself or to others. Always follow the safety precautions to reduce the risk of fire, electric shock and personal injury.
NOTE:	Advises you of information or instructions vital to the operation or maintenance of the equipment.

**SAFETY ALERT SYMBOL:**

Indicates caution or warning. May be used in conjunction with other symbols or pictographs.



DANGER: Failure to obey a safety warning will result in serious injury to yourself or to others. Always follow the safety precautions to reduce the risk of fire, electric shock and personal injury.



WARNING: Failure to obey a safety warning can result in serious injury to yourself or to others. Always follow the safety precautions to reduce the risk of fire, electric shock and personal injury.



CAUTION: Failure to obey a safety warning may result in property damage or personal injury to yourself or to others. Always follow the safety precautions to reduce the risk of fire, electric shock and personal injury.

NOTE: Advises you of information or instructions vital to the operation or maintenance of the equipment.

DOUBLE INSULATION

Double insulation is a concept in safety, in electric power tools, which eliminates the need for the usual three-wire grounded power cord. All exposed metal parts are isolated from the internal metal motor components with protecting insulation. Double insulated tools do not need to be grounded.

IMPORTANT

Servicing of a tool with double insulation requires extreme care and knowledge of the system and should be performed only by a qualified service technician. For service we suggest you return the tool to your nearest **RYOBI FACTORY** or **AUTHORIZED SERVICE CENTER** for repair. When servicing use only identical Ryobi replacement parts.

**WARNING:**

The double insulated system is intended to protect the user from shock resulting from a break in the tool's internal wiring. Observe all normal safety precautions related to avoiding electrical shock.

**WARNING:**

Do not attempt to operate this tool until you have read thoroughly and understand completely all instructions, safety rules, etc. contained in this manual. Failure to comply can result in accidents involving fire, electric shock, or serious personal injury. Save owner's manual and review frequently for continuing safe operation, and instructing others who may use this tool.

**WARNING:**

The operation of any router can result in foreign objects being thrown into your eyes, which can result in severe eye damage. Before beginning power tool operation, always wear safety goggles or safety glasses with side shields and a full face shield when needed. We recommend Wide Vision Safety Mask for use over eyeglasses or standard safety glasses with side shields.

RULES FOR SAFE OPERATION

READ ALL INSTRUCTIONS

1. **KNOW YOUR POWER TOOL.** Read owner's manual carefully. Safe operation of this power tool requires that you read and understand this owner's manual and all labels affixed to the tool. Learn its applications and limitations as well as the specific potential hazards related to this tool.
2. **GUARD AGAINST ELECTRICAL SHOCK** by preventing body contact with grounded surfaces. For example: Pipes, radiators, ranges, refrigerator enclosures.
3. **KEEP GUARDS IN PLACE** and in working order.
4. **KEEP WORK AREA CLEAN.** Cluttered areas and benches invite accidents.
5. **AVOID DANGEROUS ENVIRONMENT.** Don't use power tool in damp or wet locations or expose to rain. Keep work area well lit.
6. **KEEP CHILDREN AND VISITORS AWAY.** All visitors should wear safety glasses and be kept a safe distance from work area. Do not let visitors contact tool or extension cord.
7. **STORE IDLE TOOLS.** When not in use tools should be stored in a dry and high or locked-up place - out of the reach of children.
8. **DON'T FORCE TOOL.** It will do the job better and safer at the rate for which it was designed.
9. **USE RIGHT TOOL.** Don't force small tool or attachment to do the job of a heavy duty tool. Don't use tool for purpose not intended - for example - A circular saw should never be used for cutting tree limbs or logs.
10. **WEAR PROPER APPAREL.** Do not wear loose clothing or jewelry that can get caught in tool's moving parts and cause personal injury. Rubber gloves and nonskid footwear are recommended when working outdoors. Wear protective hair covering to contain long hair and keep it from being drawn into nearby air vents.
11. **ALWAYS WEAR SAFETY GLASSES.** Everyday eyeglasses have only impact-resistant lenses; they are **NOT** safety glasses.
12. **PROTECT YOUR LUNGS.** Wear a face or dust mask if operation is dusty.
13. **PROTECT YOUR HEARING.** Wear hearing protection during extended periods of operation.
14. **DON'T ABUSE CORD.** Never carry tool by cord or yank it to disconnect from receptacle. Keep cord from heat, oil and sharp edges.
15. **SECURE WORK.** Use clamps or a vise to hold work. It's safer than using your hand and it frees both hands to operate tool.
16. **DON'T OVERREACH.** Keep proper footing and balance at all times. Do not use on a ladder or unstable support.
17. **MAINTAIN TOOLS WITH CARE.** Keep tools sharp at all times, and clean for best and safest performance. Follow instructions for lubricating and changing accessories.
18. **DISCONNECT TOOLS.** When not in use, before servicing, or when changing attachments, blades, bits, cutters, etc., all tools should be disconnected from power supply.
19. **REMOVE ADJUSTING KEYS AND WRENCHES.** Form habit of checking to see that keys and adjusting wrenches are removed from tool before turning it on.
20. **AVOID ACCIDENTAL STARTING.** Don't carry plugged-in tools with finger on switch. Be sure switch is off when plugging in.
21. **MAKE SURE YOUR EXTENSION CORD IS IN GOOD CONDITION.** When using an extension cord, be sure to use one heavy enough to carry the current your product will draw. An undersized cord will cause a drop in line voltage resulting in loss of power and overheating. A wire gage size (A.W.G.) of at least 14 is recommended for an extension cord 25 feet or less in length. A cord exceeding 50 feet is not recommended. If in doubt, use the next heavier gage. The smaller the gage number, the heavier the cord.
22. **OUTDOOR USE EXTENSION CORDS.** When tool is used outdoors, use only extension cords suitable for use outdoors. Outdoor approved cords are marked with the suffix W-A, for example - SJTW-A or SJOW-A.
23. **KEEP CUTTERS CLEAN AND SHARP.** Sharp cutters minimize stalling and kickback.

RULES FOR SAFE OPERATION

24. **KEEP HANDS AWAY FROM CUTTING AREA.** Keep hands away from cutters. Do not reach underneath work while cutter is rotating. Do not attempt to remove material while cutter is rotating.
25. **NEVER USE IN AN EXPLOSIVE ATMOSPHERE.** Normal sparking of the motor could ignite fumes.
26. **INSPECT TOOL CORDS PERIODICALLY** and if damaged, have repaired at your nearest **RYOBI FACTORY** or **AUTHORIZED SERVICE CENTER**. Stay constantly aware of cord location.
27. **INSPECT EXTENSION CORDS PERIODICALLY** and replace if damaged.
28. **KEEP HANDLES DRY, CLEAN, AND FREE FROM OIL AND GREASE.** Always use a clean cloth when cleaning. Never use brake fluids, gasoline, petroleum-based products or any strong solvents to clean your tool.
29. **STAY ALERT.** Watch what you are doing and use common sense. Do not operate tool when you are tired. Do not rush.
30. **CHECK DAMAGED PARTS.** Before further use of the tool, a guard or other part that is damaged should be carefully checked to determine that it will operate properly and perform its intended function. Check for alignment of moving parts, binding of moving parts, breakage of parts, mounting, and any other conditions that may affect its operation. A guard or other part that is damaged should be properly repaired or replaced by an authorized service center unless indicated elsewhere in this instruction manual.
31. **DO NOT USE TOOL IF SWITCH DOES NOT TURN IT ON AND OFF.** Have switches replaced by an authorized service center.
32. **INSPECT FOR** and remove all nails from lumber before routing.
33. **DRUGS, ALCOHOL, MEDICATION.** Do not operate tool while under the influence of drugs, alcohol, or any medication.
34. **WHEN SERVICING, USE ONLY IDENTICAL RYOBI REPLACEMENT PARTS.**
35. **POLARIZED PLUGS.** To reduce the risk of electric shock, this tool has a polarized plug (one blade is wider than the other). This plug will fit in a polarized outlet only one way. If the plug does not fit fully in the outlet, reverse the plug. If it still does not fit, contact a qualified electrician to install the proper outlet. Do not change the plug in any way.
36. **DO NOT USE TOOL UNDER "BROWNOUT" OR OTHER LOW VOLTAGE CONDITIONS.** Also, do not use with any device that could cause the power supply voltage to change.
37. **WHEN USING THIS ROUTER WITH A ROUTER TABLE, HELP PREVENT POSSIBLE SERIOUS INJURY BY KEEPING THE CUTTER GUARDED AT ALL TIMES.** Use only UL listed router tables, with guards, that have been designed for use on routers that are of this type, size, and weight.
38. **SAVE THESE INSTRUCTIONS.** Review them frequently and use them to instruct others who may use this tool. If you loan someone this tool, loan them these instructions also.



Look for this symbol to point out important safety precautions. It means attention!!! Your safety is involved.

SAVE THESE INSTRUCTIONS

UNPACKING

Your RE601 router has been shipped completely assembled and ready for use. After removing it from the box, inspect it carefully to make sure no breakage or damage has occurred during shipping. If any parts are damaged or missing, contact your nearest Ryobi dealer to obtain replacement parts before attempting to operate router. A 1/4 in. (6.4 mm) bit adapter, a 24 mm wrench, phillips flat head 8 mm screws (quantity 4), owner's operating manual, and warranty registration are the only loose parts included in the box.



WARNING:

If any parts are missing, do not operate your router until the missing parts are replaced. Failure to do so could result in possible serious personal injury.

FEATURES

HEAVY DUTY MOTOR

Your router has a powerful 15 amp motor with sufficient power to handle tough routing jobs. It delivers 3 horsepower for heavy duty performance. The motor also has externally accessible brushes for ease of servicing.

SWITCH

To turn your router **ON**, depress the switch trigger. Release the switch trigger to turn your router **OFF**.

SOFT START

The soft start feature builds motor RPM gradually to minimize start-up torque.

LOCK-ON FEATURE

Your router is equipped with a **lock-on** feature that is convenient when continuous operation for extended periods of time is required. To lock on, depress the trigger, push in the lock-on button located on the side of the handle, then while holding the lock-on button pushed in, release the trigger. To release the lock, depress the trigger and release it. See *Figure 2*.

DEPTH CONTROL KNOB

A large depth control knob makes precise depth of cut changes possible. It is also very helpful when making depth of cut changes with your router mounted upside down on a router table.

DEPTH STOP

The depth stop located on the base of your router provides three adjustable stops for quick, repetitive depth of cut changes. A depth adjustment scale makes quick adjustments to depth of cut changes possible. The spring loaded adjustment knob quick releases stop bar by depressing the center of knob.

1/4 in. (6.4 mm) AND 1/2 in. (13 mm) SHANK CAPACITY

Your router has a 1/2 in. (13 mm) diameter collet that accepts cutters with 1/2 in. (13 mm) shanks. A 1/4 in. (6.4 mm) bit adapter has been provided so that cutters with 1/4 in. (6.4 mm) shank bits can also be used.

CHIP SHIELD

A clear plastic see-through chip shield has been provided on

the front of your router for protection against flying dust and chips. The shield fits the front opening of the router base. See *Figure 1*. If necessary to remove chip shield, loosen the knob screw and remove. **For your protection, do not use router without chip shield properly in place with knob screw tightened securely.**

SPINDLE LOCK

A spindle lock secures the spindle so that only one wrench is needed to loosen the collet nut and change cutters.

HANDLES

The handles on your router have been designed so that they provide for easy handling and maintaining proper control when routing.

The handles have also been designed so that they are comfortable and easy to grasp when operating in different positions.

ELECTRONIC VARIABLE CONTROL

Your router has advanced electronic features, designed to assist you in getting the maximum use from your router. By making proper speed selections, your router can be adjusted to specific routing needs. This eliminates much of the guess work previously needed to perform a given job. Both the experienced and inexperienced router users benefit, obtaining professional like results with fewer job errors.

VARIABLE SPEED

The variable speed control feature allows the router to develop a no load speed that can be adjusted from 10,000 to 22,000 RPM. The variable speed control selector is conveniently located on the side of the motor housing near the operator's hand.

Speed can be set according to the approximate cutter diameter you will be using and to the hardness of the material being cut. See the chart in figure 13, on page 13. The best cuts are made when the cutter is fed through material at the proper rate of feed.

ELECTRONIC FEEDBACK

The electronic feedback feature of your router introduces the flexibility of adjusting the motor speed to required job conditions. An electronic speed control module senses the load applied to the motor, and increases or decreases motor voltage to compensate for and maintain desired RPM.

FEATURES

KNOW YOUR ROUTER

Before attempting to use your router, familiarize yourself with all operating features and safety requirements. See *Figures 1 and 2*.

Your router is a versatile woodworking tool which will give you years of trouble-free performance. It is engineered with the professional in mind, but its ease of operation allows the amateur to produce work which is beautiful and precise.

As the name implies your router can be used for making plunge cuts in workpieces, routing grooves, edge routing, routing circles, and freehand routing. When used with recommended accessories, such as a UL listed router table or straight guide; it becomes even more versatile. Various types of cutters, both with and without roller bearings as guides also add to the versatility of this tool.

CAUTION: Use router bits for cutters only.

Also make sure all router bits and recommended accessories are in accordance with listed specifications for this tool. For example, do not use router bits that are rated at less than 25,000 RPM.

WARNING:

Do not allow familiarity with your router to make you careless. Remember that a careless fraction of a second is sufficient to inflict severe injury.

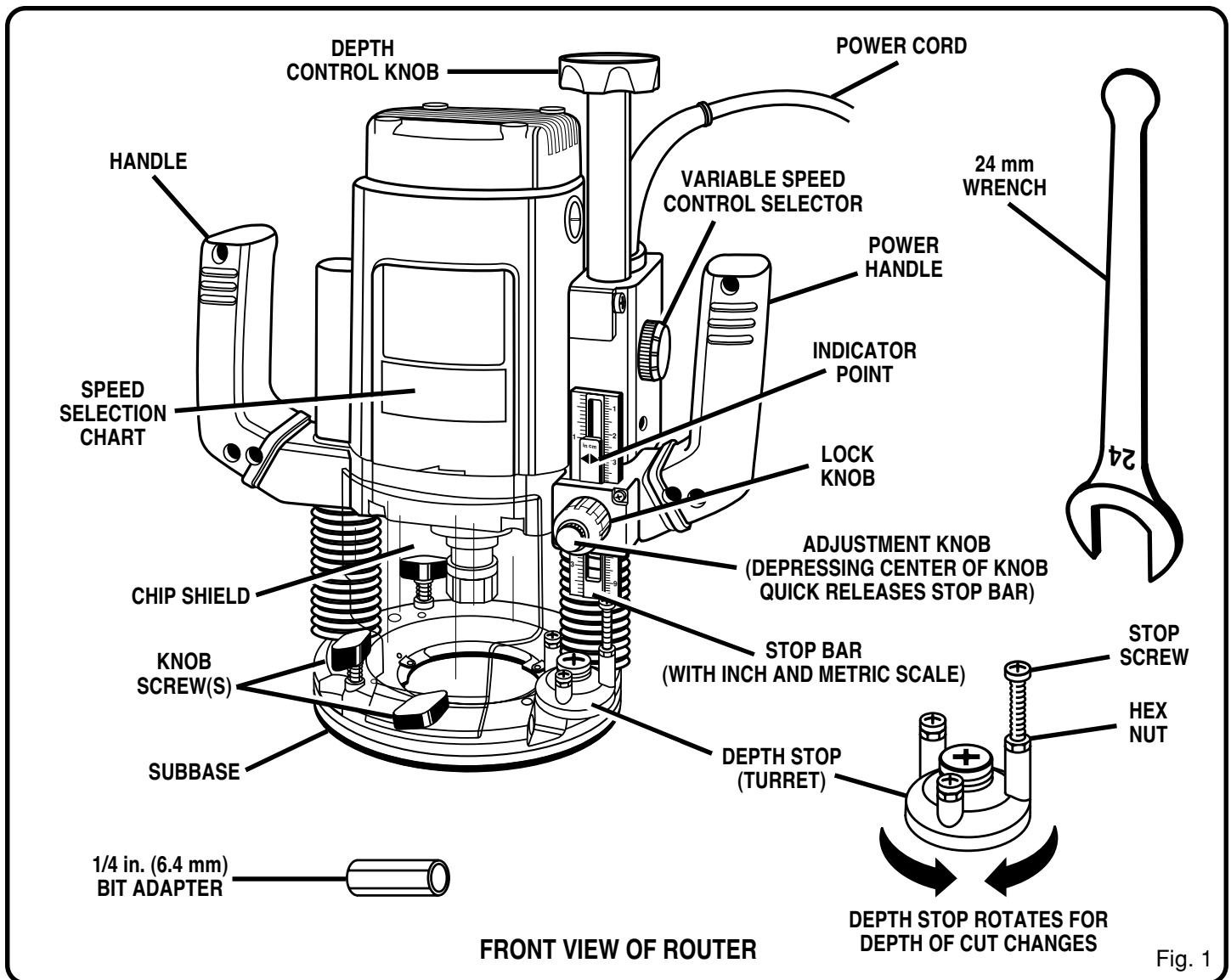

FEATURES

APPLICATIONS

(Use only for the purposes listed below)

- Routing grooves, shaping edges, freehand designs, etc. in wood.
- Chamfering, rabbeting, dadoing, and dovetailing in wood are additional applications.
- Routing edges on laminates.

ELECTRICAL CONNECTION

Your router has a precision built electric motor. It should be connected to a **power supply that is 120 volts, 60 Hz, AC only (normal household current)**. Do not operate this tool on direct current (DC). A substantial voltage drop will cause a loss of power and the motor will overheat. If your tool does not operate when plugged into an outlet, double-check the power supply.

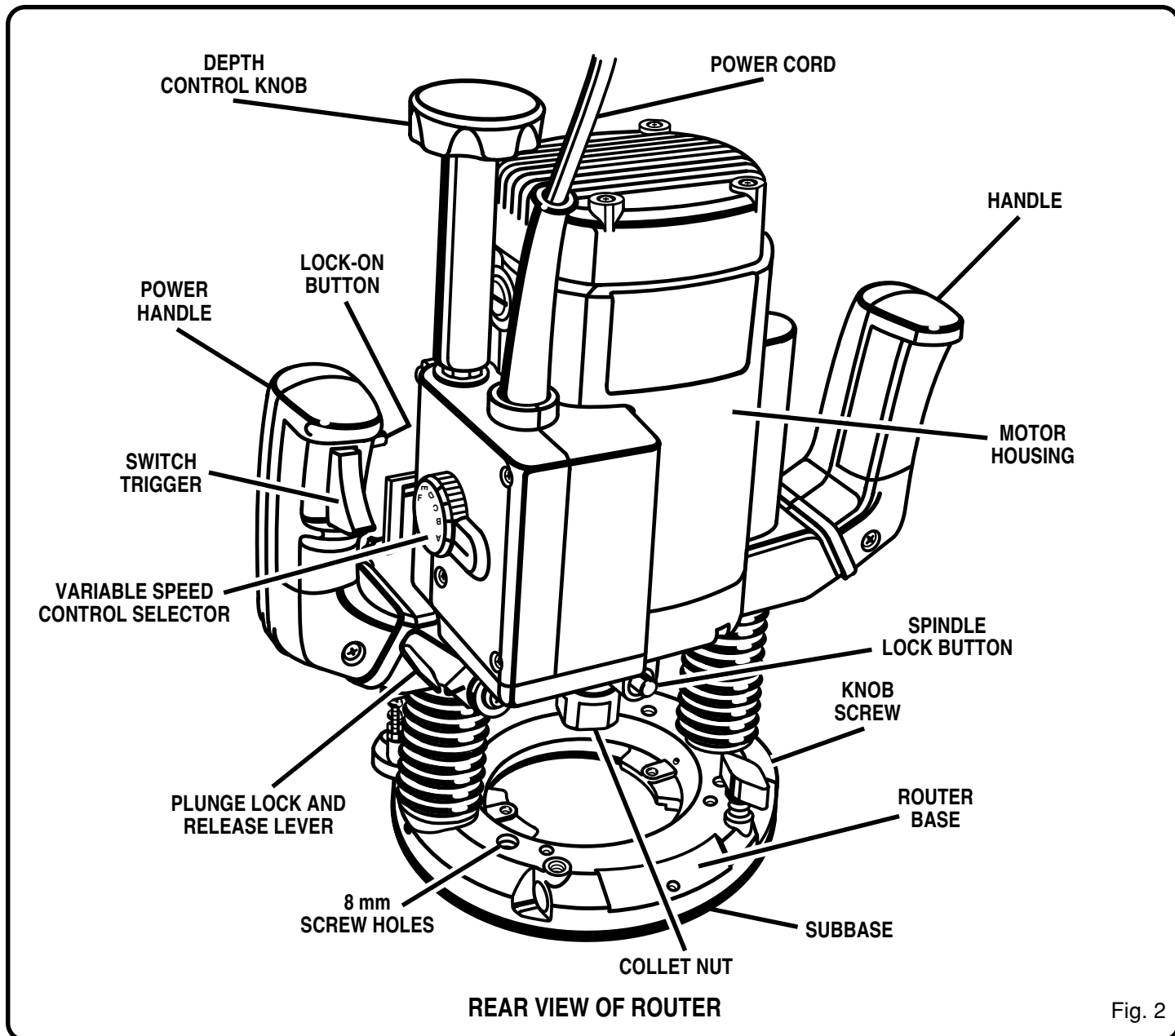

PLUNGE LOCK AND RELEASE FEATURE

See Figure 2.

Your router has a plunge lock and release lever that allows free plunging. Releasing the lever allows smooth, precise plunging action. Locking the lever secures the cutter once the desired depth of cut has been determined.

ADJUSTMENTS

WARNING:

Your router should never be connected to power supply when you are assembling parts, making adjustments, installing or removing cutters, or when not in use. Disconnecting your router will prevent accidental starting that could cause serious injury.

INSTALLING/REMOVING CUTTERS

See Figure 3.

- Unplug your router.

WARNING:

Failure to unplug your router could result in accidental starting causing serious injury.

WARNING:

To prevent damage to the spindle or spindle lock, always allow motor to come to a complete stop before engaging spindle lock.

- Lay your router on its side with the collet facing away from you and the spindle lock button facing up. See Figure 3.
- To activate spindle lock, depress spindle lock button and turn collet nut with wrench until lock mechanism interlocks.
NOTE: Once spindle lock button engages, continue to depress spindle lock button.

WARNING:

If you are changing a cutter immediately after use, be careful not to touch the cutter or collet with your hands or fingers. They will get burned because of the heat buildup from cutting. Always use the wrench provided.

- Remove cutters by turning collet nut counterclockwise enough to allow cutter to slip easily from collet. See Figure 3.
- If installing cutter for the first time, it can be installed once collet nut is loose. If changing cutters, cutter will easily slip from collet after loosening collet nut.
- The 1/2 in. (13 mm) collet is machined to precision tolerances to fit cutters with 1/2 in. (13 mm) diameter shanks.
- Insert shank of cutter into collet until shank bottoms out, then pull it out 1/16 in. (1.6 mm) to allow for expansion when the bit gets hot.
- Tighten the collet nut securely by turning clockwise with the wrench provided. See Figure 3.

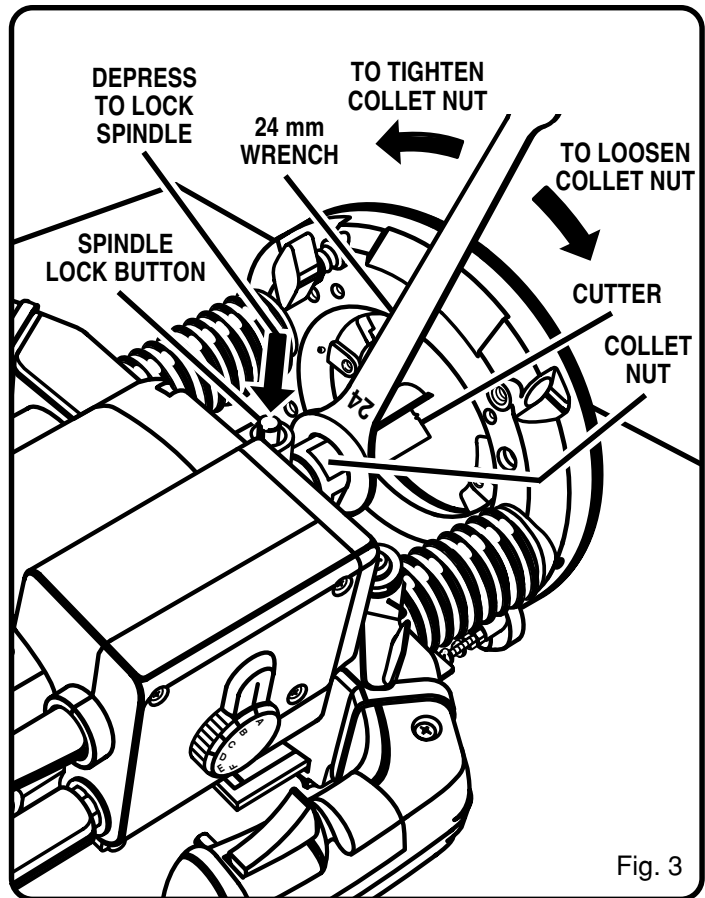

Fig. 3

WARNING:

If collet nut is not tightened securely, cutter may come out during use causing serious personal injury.

- Release spindle lock button.

WARNING:

Do not use cutters with undersized shanks. Undersized shanks will not tighten properly and could be thrown from tool causing injury.

ADJUSTMENTS

INSTALLING/REMOVING CUTTERS WITH A 1/4 in. (6.4 mm) DIAMETER SHANK

As mentioned previously, a 1/4 in. (6.4 mm) bit adapter has also been provided with your router so that cutters with 1/4 in. (6.4 mm) shank bits can be used. See Figure 4.

- If using a cutter with a 1/4 in. (6.4 mm) diameter shank, follow the instructions on the previous page to loosen the collet nut and remove any 1/2 in. (13 mm) diameter shank cutters from the collet.
- Place the 1/4 in. (6.4 mm) bit adapter provided in the collet. See Figure 4.
- Insert shank of cutter into collet until shank bottoms out, then pull it out 1/16 in. (1.6 mm) to allow for expansion when the bit gets hot.
- Tighten the collet nut securely by turning clockwise with the wrench provided. See Figure 3.



WARNING:

If collet nut is not tightened securely, cutter may come out during use causing serious personal injury.

TO SET DEPTH OF CUT

- Unplug your router.



WARNING:

Failure to unplug your router could result in accidental starting causing serious injury.

- Raise the cutter by releasing the plunge lock and release lever. See Figure 5.
- Adjust depth control knob until cutter is inside router subbase. See Figure 6.
- Place your router on a flat surface.
- Lower router until tip of cutter barely touches the workpiece. See Figure 7.
- Tighten the plunge lock and release lever to lock cutter at "zero" depth of cut. **NOTE:** If desired, adjust the depth control knob until it seats against the router housing. This will provide a positive stop at "zero" depth of cut.
- Rotate depth stop to desired position, loosen lock knob, then turn adjustment knob until stop bar touches stop screw on depth stop. See Figure 8.
- Pick a reference point on the scale.
- Next, turn adjustment knob in the opposite direction, lifting stop bar to obtain desired depth of cut. See Figure 8. For example, if setting 1/16 in. (1.6 mm) depth of cut, the scale will move 1/16 in. (1.6 mm) from the reference point.
- Tighten lock knob securely.
- Position your router so that the cutter can extend below the subbase for desired depth setting. See Figure 9.

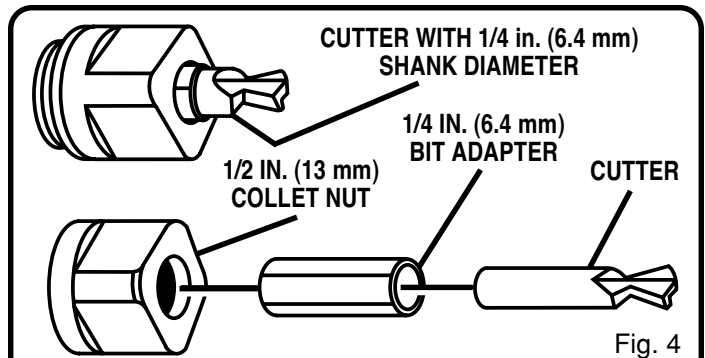

Fig. 4

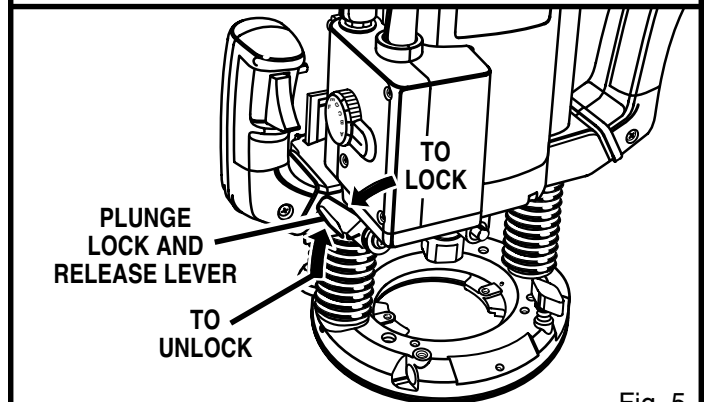

Fig. 5

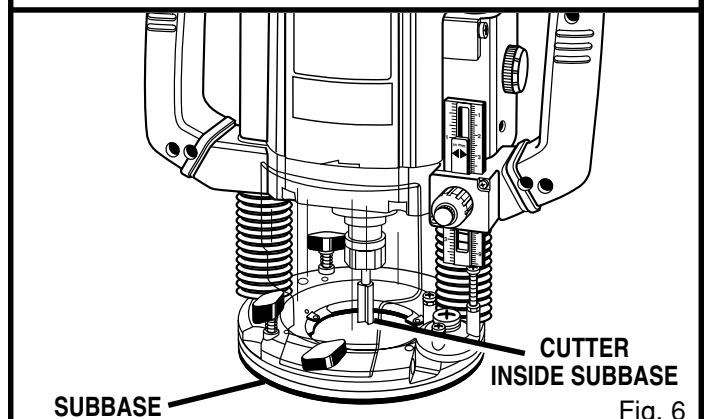

Fig. 6

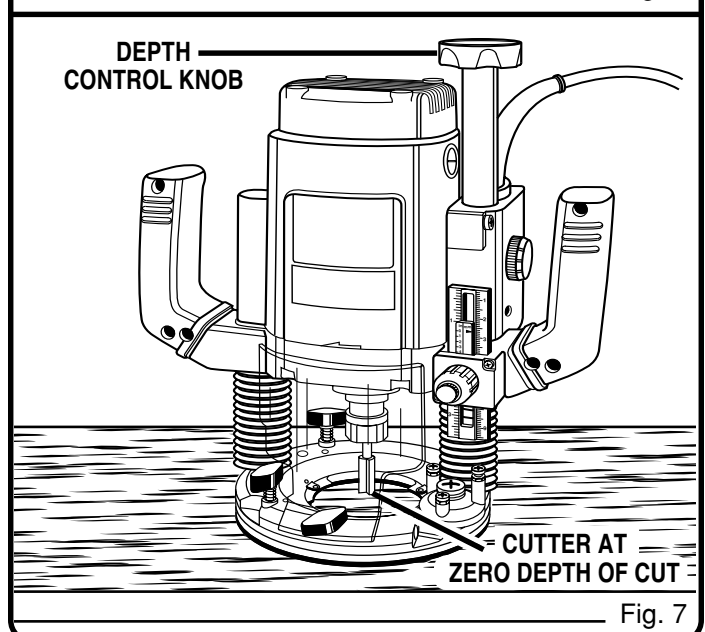

Fig. 7

ADJUSTMENTS

- Release the plunge lock and release lever.
- Grasp the handles and lower router until stop bar contacts stop screw. Tighten the plunge lock and release lever to lock the cutter at the desired depth of cut.

DEPTH STOP SYSTEM

See Figure 10.

The depth stop is located on the base of your router and makes it possible to make deep or heavy cuts in successive passes by use of preset depth of cut changes. Adjustable stops are provided, making depth of cut changes quick and easy. The depth stop, also known as a revolving turret, rotates on a ball detent design in the router base.

A preset cutting depth is achieved by plunging router until stop bar comes in contact with the stop screw on depth stop.

The adjustable stops have screws that may be adjusted approximately 1/2 in. (13 mm).

TO SET DEPTH STOP SETTINGS

- Unplug your router.



WARNING:

Failure to unplug your router could result in accidental starting causing serious injury.

- Loosen lock knob and turn adjustment knob clockwise, raising stop bar to its highest position.
- Determine which adjustable stops will be used to reach desired depth of cut.
- The stop screw on each stop can be adjusted to the desired height by loosening the hex nut with a 3/8 in. (10 mm) open end wrench and turning it in or out with your fingers. Secure stop screw in position by retightening hex nut with wrench. **Do not overtighten hex nut.** Set stops to desired heights, spreading the entire depth of cut over the number of stops used.
- Rotate depth stop until the highest depth stop is aligned with the stop bar.
- Raise cutter by releasing plunge lock and release lever.
- Place router on a flat surface, and lower router until tip of cutter barely touches flat surface.
- Tighten plunge lock and release lever to lock cutter at "zero" depth of cut.
- Turn adjustment knob counterclockwise to lower stop bar against stop, then tighten lock knob securely. The highest stop now becomes "zero" depth of cut setting.
- Release plunge lock and release lever and raise router. Rotate depth stop so that next highest depth stop aligns with stop bar. This locates cutter for the initial pass.
- Tighten plunge lock and release lever, locking cutter at desired depth of cut.
- Rotate depth stop after each pass. Make as many successive passes as needed to obtain desired depth of cut, progressively lowering router to next depth of cut setting with each pass.

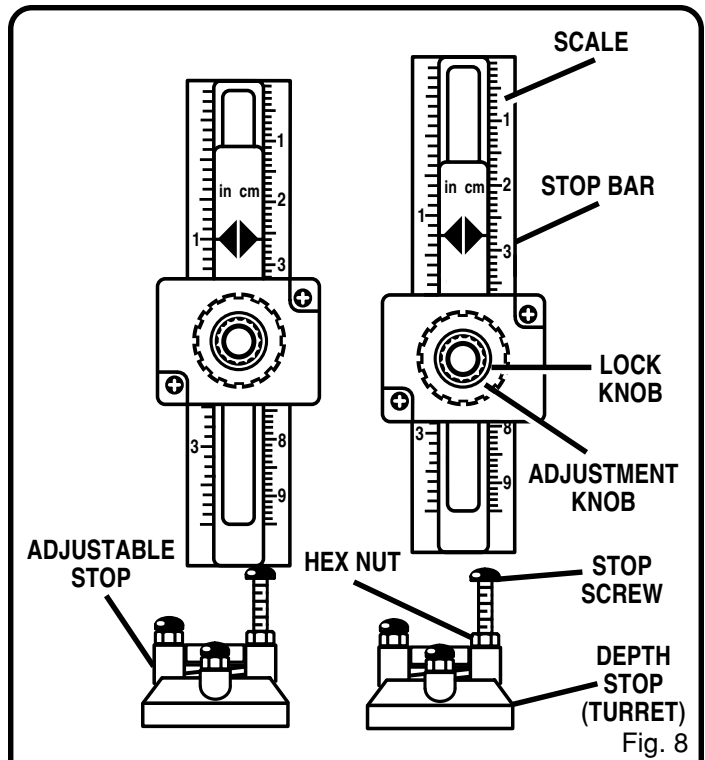

Fig. 8

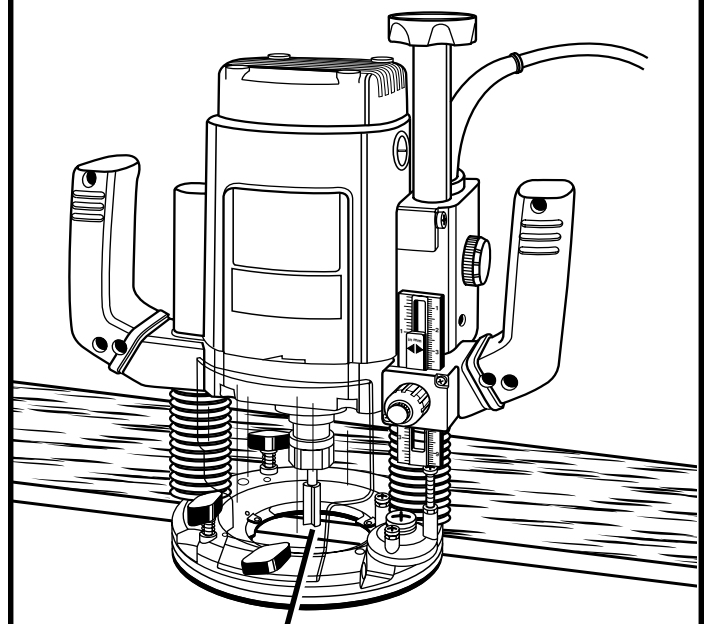

Fig. 9

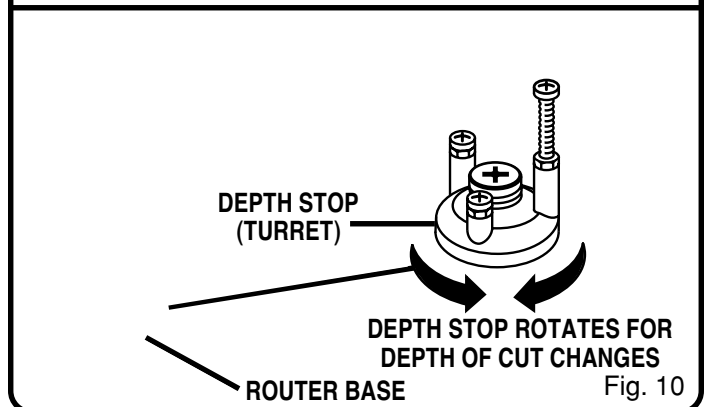

Fig. 10

ADJUSTMENTS

DEPTH OF CUT ADJUSTMENTS

When routing a groove or dado that is too deep to safely cut in one pass, it is best to make the cut in several passes. The proper depth of cut depends on several factors: the horsepower of the router motor, the type of cutter being used, and the type of wood being routed. A lightweight router with low horsepower is designed for making shallow cuts. A router with a high horsepower rating can safely cut much deeper. A small router bit, such as a 1/4 in. (6.4 mm) shank veining bit with a 1/16 in. (1.6 mm) cutting diameter, is designed to remove only small amounts of wood. Large bits, such as a 1/2 in. (13 mm) shank straight-flute bit are made to remove a large amount of wood in a single pass. Router cuts can be made deeper in soft woods, such as white pine, than in tough hardwoods like oak or maple.

Based upon these considerations, choose a depth of cut that will not place excessive strain on the router motor. If you find that extra force is needed to make the pass or that the motor speed slows down considerably, turn off the router and reduce the depth of cut. Then, make the cut in two or more passes. The depth of each pass can be preset by using the three positions on the depth stop. Set the depth of cut, using the lowest stop. Then, rotate the depth stop so that the highest stop screw is under the scale. Rotate the depth stop assembly after each pass. The screws on the stops can be adjusted to the desired height by first loosening the lock nuts, then turning the screws in or out with a phillips head screwdriver. Retighten the lock nut to secure the depth stop screw in position. See Figure 10.

DEPTH CONTROL KNOB

See Figure 11.

Fine adjustments can be made to the depth of cut by use of the depth control knob. Another primary use of the depth control knob is setting depth of cut when router is mounted upside down on a router table. **NOTE:** The weight of the router plus the position it is in when mounted to a router table make it necessary to use the depth control knob.

TO SET DEPTH OF CUT WITH DEPTH CONTROL KNOB

- Unplug your router.



WARNING:

Failure to unplug your router could result in accidental starting causing serious injury.

- Loosen lock knob and turn adjustment knob so that stop bar is not touching stop screws.

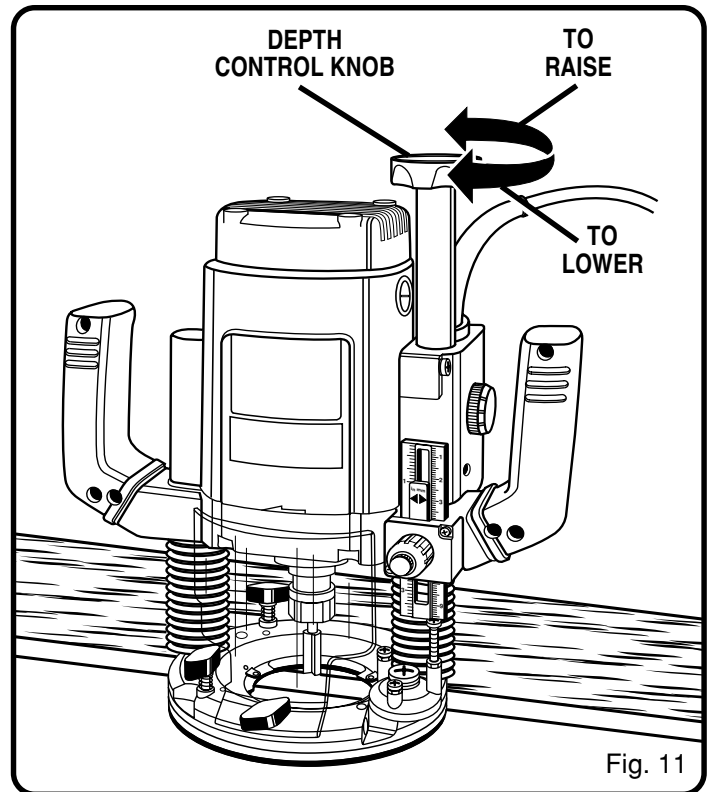

Fig. 11

- Release plunge lock and release lever and allow router to return to its uppermost position against hex nut.
- Plunge router until cutter reaches approximate desired depth of cut. Then tighten plunge lock and release lever, temporarily locking cutter at desired depth of cut.
- Turn depth control knob clockwise until it seats against motor housing of your router. **Do not overtighten.**
- Release plunge lock and release lever and turn depth control knob until cutter reaches desired depth of cut. Turn depth control knob clockwise to lower the router and counterclockwise to raise the router. **Always make sure plunge lock is released and router is free before setting depth of cut with depth control knob.**
- Tighten plunge lock and release lever, locking cutter at desired depth of cut.
- Turn adjustment knob and adjust stop bar until it touches the desired stop screw.
- Tighten lock knob securely.

Depth control knob is spring loaded against hex nut. If you adjust it too far and it pops off threaded rod, refer to **DEPTH CONTROL KNOB ADJUSTMENTS** in maintenance section for proper assembly.

ADJUSTMENTS

SCALE

See Figure 12.

Your router has a dual inch and metric scale provided on the stop bar. Each mark on the inch scale makes 1/16 in. depth of cut changes possible. Each mark on the centimeter scale makes 1 mm depth of cut changes possible. The indicator point located on the housing provides a reference point for the scale.

- Select either the inch or metric indicator point.
- Identify the scale mark currently aligned with the indicator mark.
- Loosen lock knob and turn adjustment knob to change the scale and stop bar position.
- Continue to turn adjustment knob until the indicator point aligns with the new desired depth of cut mark on the scale.
- Tighten lock knob securely to lock stop bar in new position.

The cutter position will now increase or decrease the exact distance the stop bar was adjusted.

If an additional 1/16 in. depth of cut is needed, loosen lock knob and turn adjustment knob further until indicator point aligns with the next 1/16 in. mark on the scale.

Tighten lock knob securely to lock stop bar in new position.

Repeat the steps above as needed if a deeper depth of cut is required.

Remember: The inch marks on the scale indicate a 1/16 in. change in depth setting; each mark on the centimeter scale side of the stop bar equals a 1 mm change in depth setting; the depth control knob can also be used for making precise or fine adjustments to depth of cut; and depressing center of depth adjustment knob quick releases stop bar.

VARIABLE SPEED CONTROL SELECTOR

See Figure 13.

Your router has a variable speed control selector designed to allow operator control of speed and torque limits. You can make speed selections best suited to the type of cut, the material being cut, and the size of bit being used. The variable speed control selector allows you to adjust router speed from 10,000 to 22,000 rpm. There is a six step scale labeled **A** through **F** on the variable speed control selector. To increase the speed and torque of your router, turn the variable speed control selector to a higher setting. Turn to a lower setting to decrease speed and torque.

NOTE: If you do not want to use the variable speed control selector, turn to the highest possible setting **F**.

The speed selection chart shown gives suggested speed settings based on the diameter of the cutter and the type of material being routed. See Figure 13.

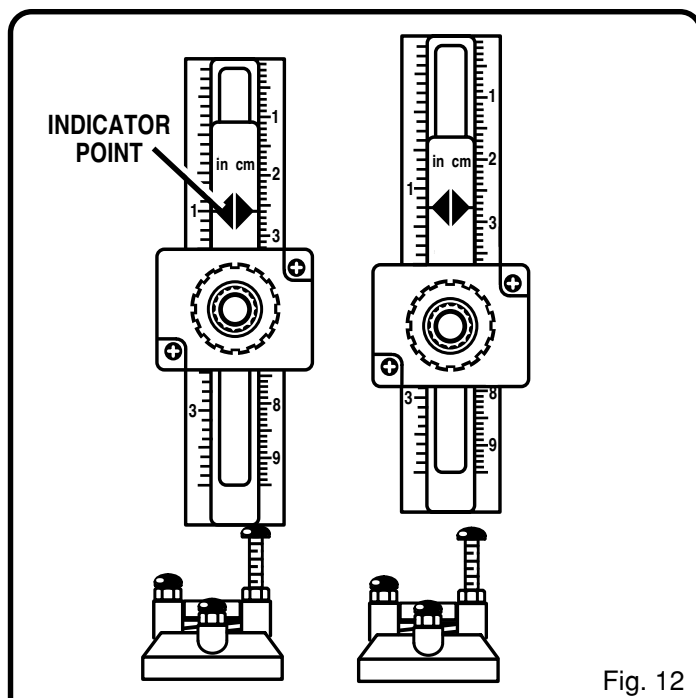

Fig. 12

SPEED SELECTION CHART				
R.P.M. A=10,000 B=11,000 C=13,000 D=16,000 E=19,000 F=23,000				
CUTTER DIA FROM TO	CONTROL SETTING			
	SOFT WOOD	HARD WOOD	PLASTICS	ALUMINUM
1/8" (3mm) 1/4" (6mm)	F	E	C	C
1/4" (6mm) 5/16" (8mm)	E	D	C	B
5/16" (8mm) 3/8" (10mm)	D	C	B	A
3/8" (10mm) 1/2" (12mm)	D	B	A	A
1/2" (12mm) 3/4" (20mm)	C	B	A	A
3/4" (20mm) 1" (25mm)	C	B	A	A
* 1" (25mm) 2" (50mm)	C	B	A	A

*--CHAMFERING ONLY

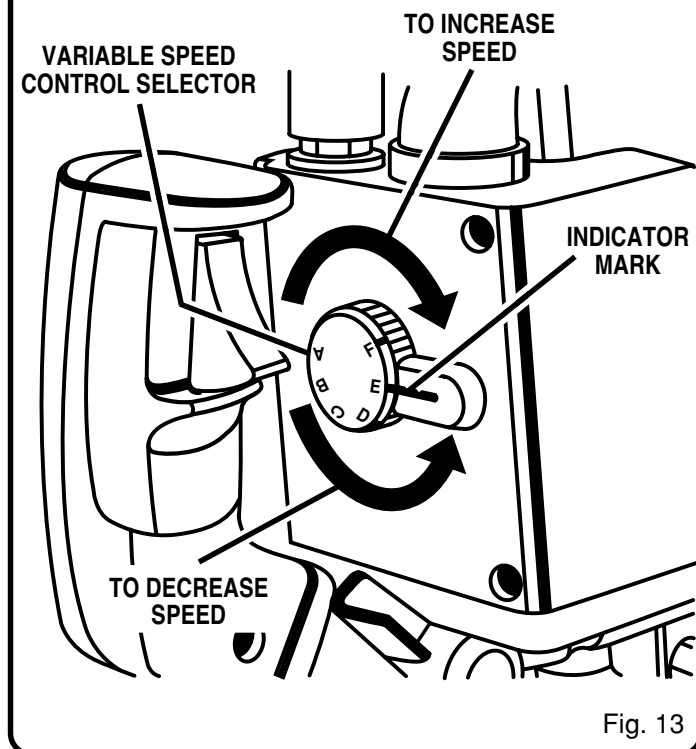

Fig. 13

OPERATION

PRACTICE BEFORE ACTUAL USE

We suggest that you practice with the variable speed feature of your router before installing a cutter and making cuts in wood. **Check the following before connecting your router to power supply:**

- Make sure power supply is 120 volts, 60 Hz, AC only.
- Make sure the trigger is not in the **lock-on** position.
- Make sure there is not a cutter in the collet.
- Make sure the collet does not extend below the subbase.
- Choose the desired speed from the speed selection chart. See Figure 13.
- Turn the variable speed control selector to the desired setting. Align desired setting on the variable speed control selector with indicator mark on the housing.
- Plug your router into power supply source.
- Grasp your router firmly with both hands and depress switch trigger to turn on.

WARNING:

Always wear safety goggles or safety glasses with side shields when operating your router. Failure to do so could result in dust, shavings, chips, loose particles or foreign objects being thrown into your eyes, causing possible serious injury. If operation is dusty, also wear a face or dust mask.

WARNING:

Before connecting your router to power supply, always check to be sure switch is not in **lock-on** position. Failure to do so could result in accidental starting of your router resulting in possible serious injury.

ROUTING

For ease of operation and maintaining proper control, your router has two handles, one on each side of the router base. When using your router hold it firmly with both hands as shown in figure 14.

Before starting router, unplug it and make sure cutter is securely tightened in collet nut and that depth of cut is properly set.

Plug router into power supply, turn it on, and let motor build to its full speed, then gradually plunge or feed cutter into workpiece. **DO NOT** let the cutter contact workpiece before turning on router and allowing it to develop full speed.

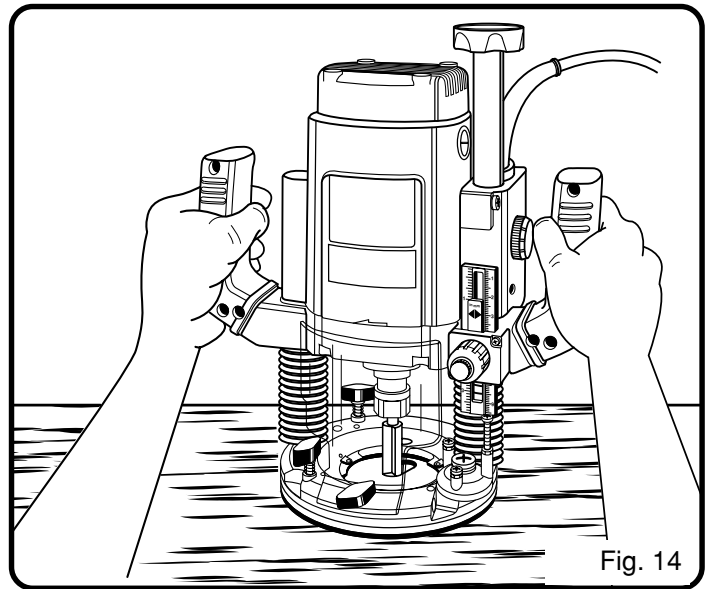

Remain alert and watch what you are doing. **DO NOT** operate router when fatigued or under the influence of drugs, alcohol, or any medication.

FEED DIRECTION

When routing, the cutter rotates clockwise. Therefore, you should feed the router into the workpiece from left to right. When fed from left to right, the rotation of the cutter pulls the router against the workpiece. If fed in the opposite direction, the rotation forces of the spinning bit will tend to throw the router away from the workpiece. This could cause loss of control of your router. See Figure 18.

RATE OF FEED

IMPORTANT: The whole "secret" of professional routing and edge shaping lies in making a careful setup for the cut to be made and in selecting the proper rate of feed.

The proper rate of feed depends on several factors: the hardness and moisture content of the wood, the depth of cut, and the cutting diameter of the bit. When cutting shallow grooves in soft woods such as pine, a faster rate of feed can be used. When making deep cuts in hardwoods such as oak, a slower rate of feed will be required.

The best rate of feed is one that does not slow down the router motor more than one-third of its no-load speed. If the router is fed too fast, it will take large chips out of the wood and leave gouge marks. If the router is fed too slow, it will scorch or burn the wood.

OPERATION

PROPER FEEDING

The right feed is neither too fast nor too slow. It is the rate at which the bit is being advanced firmly to produce a continuous spiral of uniform chips — without hogging into the wood to make large individual chips or, on the other hand, to create only sawdust. If you are making a small diameter, shallow groove in soft, dry wood, the proper feed may be about as fast as you can travel your router along your guide line. On the other hand, if the bit is a large one, the cut is deep or the wood is hard to cut, the proper feed may be a very slow one. Then, again, a cross-grain cut may require a slower pace than an identical with grain cut in the same workpiece.

There is no fixed rule. You will learn by experience from practice and use. The best rate of feed is determined by listening to the sound of the router motor and by feeling the progress of each cut. Always test a cut on a scrap piece of the workpiece wood, beforehand.

SPEED SELECTION

In general, if the material being cut is hard, the cutter size is large, or the depth of cut is deep, then your router should be run at slower speeds. When these situations exist, turn the variable speed control selector until the desired speed is reached. See Figure 13.

NOTE: Carbide cutters cut at higher speeds than steel cutters and should be used when cutting very hard materials. Keep cutters sharp at all times.

FORCE FEEDING

Clean, smooth routing and edge shaping can be done only when the bit is revolving at a relatively high speed and is taking very small bites to produce tiny, cleanly severed chips. If your router is forced to move forward too fast, the RPM of the bit becomes slower than normal in relation to its forward movement. As a result, the bit must take bigger bites as it revolves. “Bigger bites” mean bigger chips, and a rougher finish. Bigger chips also require more power, which could result in the router motor becoming overloaded.

Under extreme force-feeding conditions the relative RPM of the bit can become so slow — and the bites it has to take so large — that chips will be partially knocked off (rather than fully cut off), with resulting splintering and gouging of the workpiece. See Figure 15.

Your Ryobi router is an extremely high-speed tool (10,000 - 22,000 RPM no-load speed), and will make clean, smooth cuts if allowed to run freely without the overload of a forced (too fast) feed. Three things that cause “force feeding” are bit size, depth-of-cut, and workpiece characteristics. The larger the bit or the deeper the cut, the more slowly the router should be advanced. If the wood is very hard, knotty, gummy or damp, the operating pace must be slowed still more.

You can always detect “force feeding” by the sound of the motor. Its high-pitched whine will sound lower and stronger as it loses speed. Also, the strain of holding the tool will be noticeably increased.

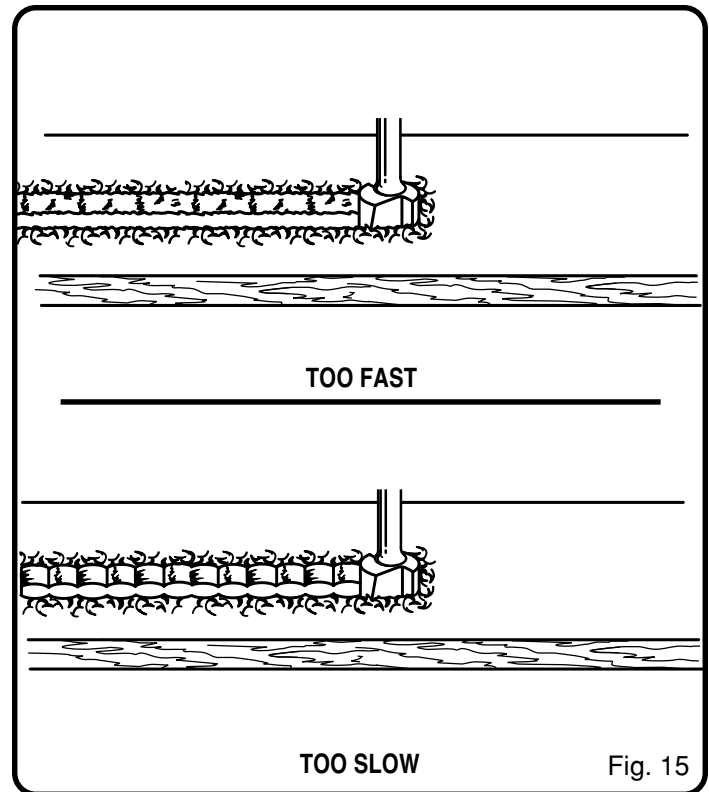

TOO SLOW FEEDING

It is possible to spoil a cut by moving the router forward too slowly. When it is advanced into the work too slowly, a revolving bit does not dig into new wood fast enough to take a bite; instead, it simply scrapes away sawdust-like particles. Scraping produces heat, which can glaze, burn, or mar the cut. In extreme cases, it can even overheat the bit so as to destroy its hardness.

In addition, it is more difficult to control a router when the bit is scraping instead of cutting. With practically no load on the motor the bit will be revolving at close to top RPM, and will have a much greater than normal tendency to bounce off the sides of the cut (especially, if the wood has a pronounced grain with hard and soft areas). As a result, the cut produced may have rippled, instead of straight sides. See Figure 15.

“Too-slow feeding” can also cause your router to take off in a wrong direction from the intended line of cut. **Always grasp and hold your router firmly with both hands when routing.**

You can detect “too-slow feeding” by the runaway too-highly pitched sound of the motor; or by feeling the “wobble” of the bit in the cut.

OPERATION

DEPTH OF CUT

As previously mentioned, the depth of cut is important because it affects the rate of feed which, in turn, affects the quality of a cut (and, also, the possibility of damage to your router motor and bit). A deep cut requires a slower feed than a shallow one, and a too deep cut will cause you to slow the feed so much that the bit is no longer cutting, it is scraping, instead.

Making a deep cut is never advisable. The smaller bits — especially those only 1/16 inch (1.6 mm) in diameter — are easily broken off when subjected to too much side thrust. A large enough bit may not be broken off, but if the cut is too deep a rough cut will result — and it may be very difficult to guide and control the bit as desired. For these reasons, we recommend that several passes be made to reach deeper cuts. See Figure 16.

To make deeper cuts it is therefore necessary to make as many successive passes as required, lowering the bit for each new pass. In order to save time, do all the cutting necessary at one depth setting, before lowering the bit for the next pass. This will also assure a uniform depth when the final pass is completed. See Figure 17.

DIRECTION OF FEED AND THRUST

See Figures 18 and 19.

The router motor and bit revolve in a clockwise direction. This gives the tool a slight tendency to twist (in your hands) in a counterclockwise direction, especially when the motor is starting up.

Because of the extremely high speed of bit rotation during a “proper feeding” operation, there is very little kickback to contend with under normal conditions. However, should the bit strike a knot, hard grain, foreign object, etc. that would affect the normal progress of the cutting action, there will be a slight kickback—sufficient to spoil the trueness of your cut if you are not prepared. Such a kickback is always in the direction opposite to the direction of bit rotation.

To guard against such a kickback, plan your setup and direction of feed so that you will always be thrusting the tool—to hold it against whatever you are using to guide the cut—in the same direction that the leading edge of the bit is moving. In short, the thrust should be in a direction that keeps the sharp edges of the bit continuously biting straight into new (uncut) wood.

ROUTING

Whenever you are routing a groove, your travel should be in a direction that places whatever guide you are using at the right-hand side. In short, when the guide is positioned as shown in the first part of Figure 19, tool travel should be left to right and counterclockwise around curves. When the guide is positioned as shown in the second part of Figure 19, tool travel should be right to left and clockwise around curves. If there is a choice, the first setup is generally the easiest to use. In either case, the sideways thrust you use is against the guide.

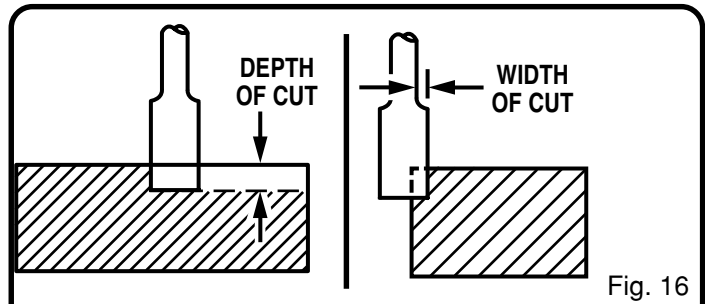

Fig. 16

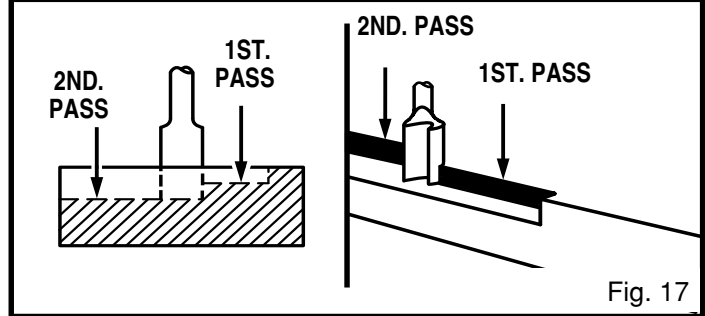

Fig. 17

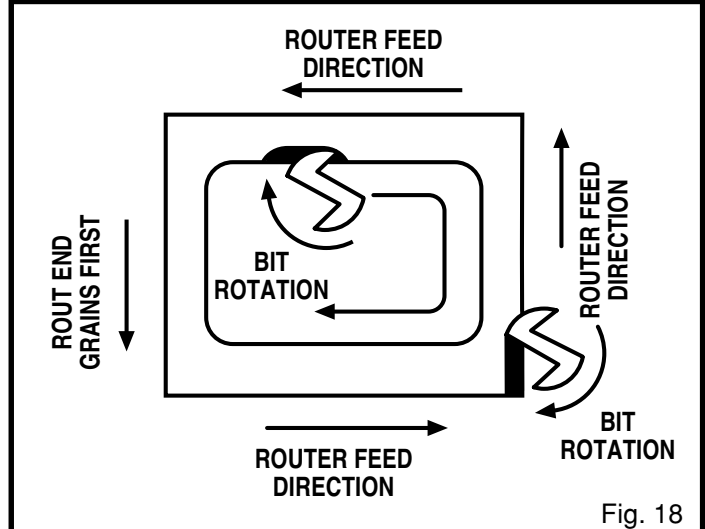

Fig. 18

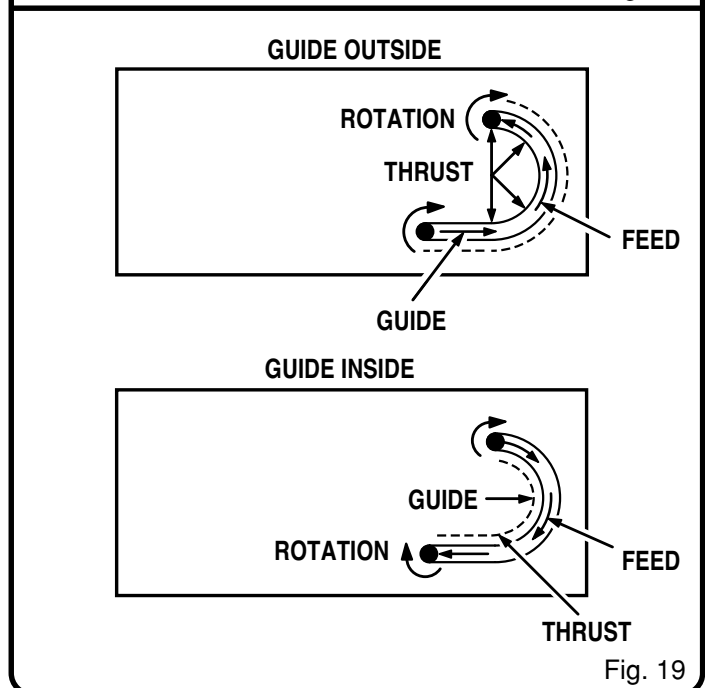

Fig. 19

OPERATION

EDGE ROUTING

Place your router on workpiece, making sure the router bit does not contact workpiece. Turn router on and let motor build to its full speed. Begin your cut, gradually feeding cutter into workpiece.

WARNING:

Keep a firm grip on router with both hands at all times. Failure to do so could result in loss of control leading to possible serious injury.

Upon completion of cut, turn motor off and let it come to a complete stop before removing router from work surface.

WARNING:

Never pull router out of work and place upside down on work surface before the cutter stops.

EDGING WITH PILOT BITS

See Figure 20.

Rabbets and molded edges can be cut using piloted cutters. The pilot extends below the cutter. Some pilots are solid extensions of the cutter. Others are ball bearing guides that are fastened to the end of the cutter. The pilots allow the cutters to turn while the pilot follows the edge of the workpiece.

Arbor-type bits with pilots are excellent for quick, easy, edge shaping. They will follow workpiece edges that are either straight or curved. The pilot prevents the bit from making too deep a cut; and holding the pilot firmly in contact with the workpiece edge throughout prevents the cut from becoming too shallow.

Whenever the workpiece thickness together with the desired depth of cut (as adjusted by router depth setting) are such that only the top part of the edge is to be shaped (leaving at least a 1/16 inch (1.6 mm) thick uncut portion at bottom), the pilot can ride against the uncut portion, which will serve to guide it. See Figure 20. However, if the workpiece is too thin or the bit set too low so that there will be no uncut edge to ride the pilot against, an extra board to act as a guide must be placed under the workpiece. This “guide” board must have exactly the same contour — straight or curved — as the workpiece edge. If it is positioned so that its edge is flush with the workpiece edge, the bit will make a full cut (in as far as the bit radius). On the other hand, if the guide is positioned as shown in Figure 20 (out from the workpiece edge), the bit will make less than a full cut — which will alter the shape of the finished edge.

NOTE: If desired any of the piloted bits can be used without a pilot for edge shaping with guides, as preceding. Also, the size (diameter) of the pilot that is used determines the maximum cut width that can be made with the pilot against the workpiece edge (the small pilot exposes all of the bit; the large one reduces this amount by 1/16 inch (1.6 mm)).

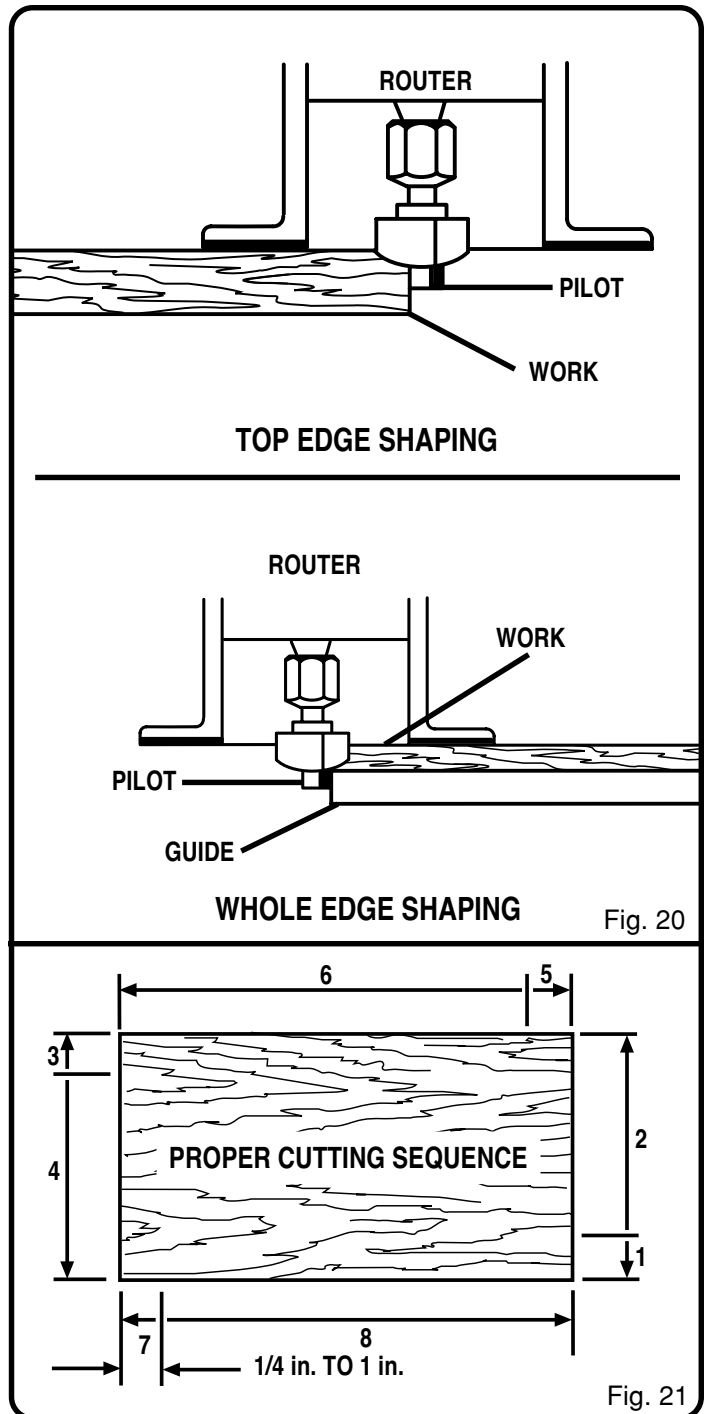

Fig. 20

Fig. 21

When routing all the edges of a panel or board, rout the end grain first. Any splintering that occurs at the corners will then be removed when routing the edge. Start each side 1/4 in. (6.4 mm) away from the end. Feed the cutter into the wood until the pilot contacts the uncut edge. Then, slowly back the router to shape the corner. Next, move the router forward to shape the rest of the edge. Be careful to keep the pilot pressed against the uncut edge. Repeat this procedure on each side of the panel. Figure 21 shows the proper sequence of cuts to make when edge routing four sides of a panel.

OPERATION

ROUTING GROOVES

See Figure 22.

When routing across the face of boards, set router at desired depth of cut, place the edge of router base against workpiece, and turn on your router. Slowly feed the cutter into the workpiece along desired line of cut.

WARNING:

If desired depth of cut is greater than can be safely cut in one pass, make cuts in two or more passes.

When routing straight cuts across stock, clamp a straight edge to the workpiece to use as a guide. Position the straightedge parallel to the line of cut and offset the distance between the cutting edge of the cutter and the edge of the router base. Hold the router base against the straightedge and rout the groove.

When routing a groove wider than the diameter of the cutter, clamp a straightedge on both sides of the cutting line. Position both guides parallel to the desired line of cut and spaced equal distances from the desired edges of the groove. Rout along one guide; then, reverse direction and rout along the other guide. Clean out any remaining waste in the center of the groove freehand.

ROUTER TABLES

WARNING:

Do not use with router tables that fail to conform to safe woodworking practices and offer proper guarding for the cutter. Failure to comply can result in an accident causing possible serious injury.

The use of Ryobi routers in router tables offered by other manufacturers has not been investigated by Ryobi for compliance with applicable safety standards.

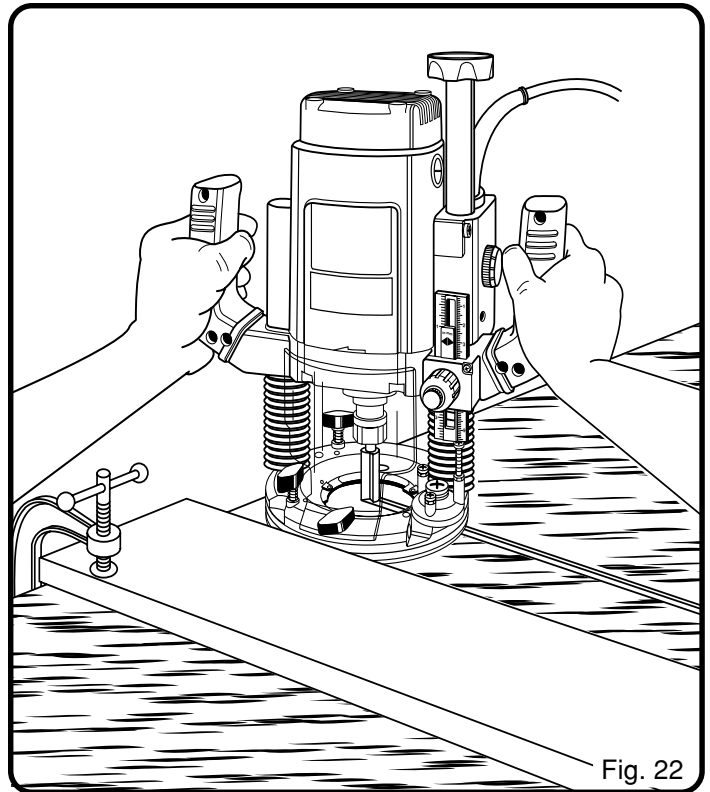

ROUTER TABLE USE

If you mount your RE601 router to a router table or the BT3000 accessory table, use only the four 8 mm tapped screw holes in the router base and the 8 mm (M8 x 25) phillips flat head screws provided with your router.

NOTE: Router subbase must be removed in order to gain access to the four 8 mm tapped holes.

WARNING:

Do not use the four 4 mm subbase screws or the respective 4 mm tapped subbase screw holes for mounting router to a router table. These screws and screw holes will not secure router to router table properly and could result in an accident causing possible serious injury.

OPERATION

WARNING:

Do not use large router bits for freehand routing. Use of large router bits when freehand routing could cause loss of control or create other hazardous conditions that could cause possible serious personal injury. When using a UL listed router table, large router bits should be used for edging only. Do not use router bits that are larger in diameter than the opening in router base for any purpose.

FREEHAND ROUTING

See Figure 23.

When used freehand, your router becomes a flexible and versatile tool. This flexibility makes it possible to easily rout signs, relief sculptures, etc.

There are two basic techniques for freehand routing:

- Routing letters, grooves, and patterns into wood. See Figure 23.
- Routing out the background, leaving the letters or pattern raised above the surface.

When freehand routing, we suggest the following:

- Draw or layout the pattern on workpiece.
- Choose the appropriate cutter. **NOTE:** A core box or V-groove bit is often used for routing letters and engraving objects. Straight bits and ball mills are often used to make relief carvings. Veining bits are used to carve small, intricate details.
- Rout the pattern in two or more passes. Make the first pass at 25% of the desired depth of cut. This will provide better control as well as being a guide for the next pass.

Freehand routing is an excellent example of how to use the plunge routing feature of your router:

- Choose the appropriate cutter, set desired depth of cut, carefully check setup, and secure workpiece.
- Make a test cut in a scrap piece of wood from the same workpiece if possible.
- Release plunge lock and release lever and raise cutter from any preset depth of cut. This also permits raising cutter inside router subbase.

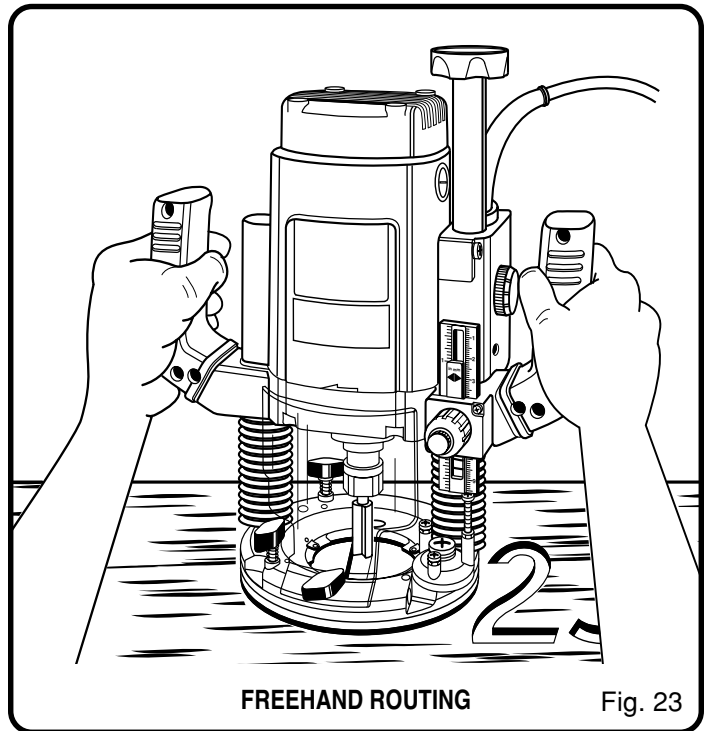

- Place router on workpiece inside pattern to be routed.
- Grasp handles securely and depress switch trigger to start your router.
- Let motor build to full speed, then gradually plunge cutter into workpiece until stop bar comes into contact with stop screw on depth stop.
- Tighten plunge lock and release lever to secure depth of cut setting.
- Begin routing out the pattern, continuing until a complete pass at this depth of cut has been made.
- Several cuts that require repositioning of router may be needed for a particular job. If this situation exists, release plunge lock and release lever and raise cutter inside router subbase after each cut, reposition router for next cut, gradually plunge cutter into workpiece until stop bar contacts stop screw, tighten plunge lock and release lever, and continue routing.

MAINTENANCE

WARNING:

When servicing use only identical Ryobi replacement parts. Use of any other parts may create a hazard or cause product damage.

WARNING:

Unplug your router from its power supply before making any adjustments or performing any maintenance procedure.

DEPTH CONTROL KNOB ADJUSTMENTS

See Figure 24.

The depth control knob is spring loaded against hex nut to prevent router motor from accidentally separating from router base. If depth control knob is turned too far up depth adjustment rod, the spring will cause depth control knob to pop off before hex nut. Do not remove hex nut. It should remain on depth adjustment rod at all times. This is especially important when using router upside down on a router table.

TO REPLACE DEPTH CONTROL KNOB:

- Unplug your router.

WARNING:

Failure to unplug your router could result in accidental starting causing serious injury.

- Turn hex nut counterclockwise until 1/4 in. (6.4 mm) of threads are remaining at the top of depth adjustment rod.
- Place compression spring on top of hex nut as shown in figure 24.
- Place depth control knob on top of compression spring.
- Carefully compress spring by pushing down on top of depth control knob.
- With spring compressed, align hex shaped recess in depth control knob with hex nut.
- Thread depth control knob clockwise onto depth adjustment rod.
- Turn depth control knob until desired depth of cut is reached.

Do not replace depth control knob without compression spring.

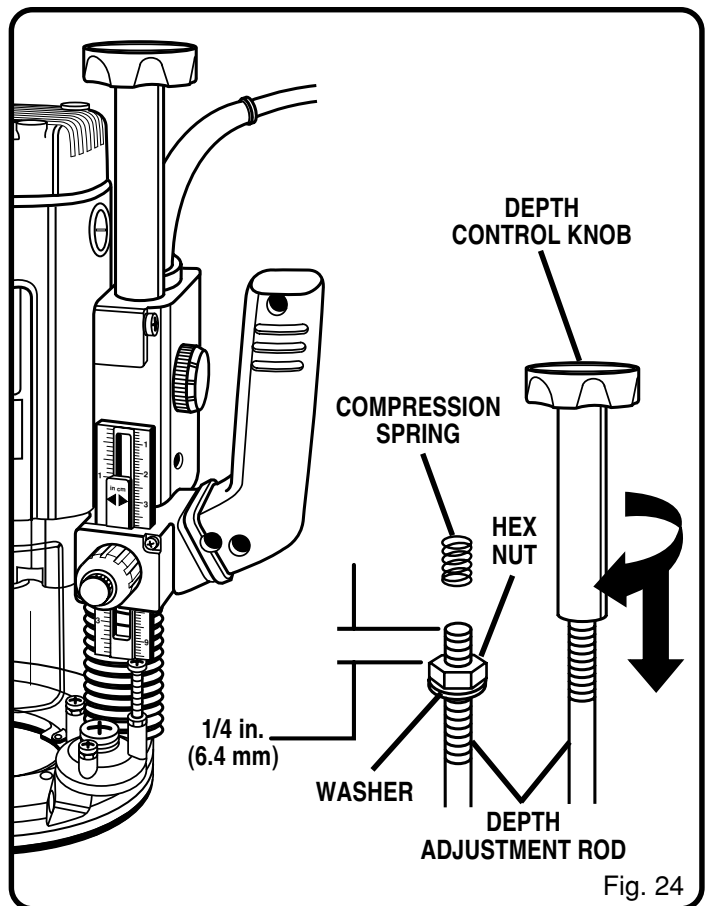

WARNING:

Replacing depth control knob without compression spring could result in depth control knob and hex nut vibrating off depth adjustment rod during use. This situation could cause motor to separate from router base, resulting in possible serious personal injury.

MAINTENANCE



WARNING:

To ensure safety and reliability, all repairs—with the exception of the externally accessible brushes—should be performed by a Ryobi Factory or Authorized Service Center.

BRUSH REPLACEMENT

See Figure 25.

Your router has externally accessible brush assemblies that should be periodically checked for wear.

PROCEED AS FOLLOWS WHEN REPLACEMENT IS REQUIRED:

- Unplug your router.



WARNING:

Failure to unplug your router could result in accidental starting causing serious injury.

- Remove depth control knob and compression spring. See **DEPTH CONTROL KNOB ADJUSTMENTS** for reference.
- Remove brush cap with a screwdriver. Brush assembly is spring loaded and will pop out when you remove brush cap.
- Remove brush assembly.
- Check for wear. If worn, always replace in pairs. **Do not** replace one side without replacing the other.
- Reassemble using new brush assemblies. Make sure curvature of brush matches curvature of motor and that brush moves freely in brush tube.
- Make sure brush cap is oriented correctly (straight) and replace.
- Tighten brush cap securely. **Do not** overtighten.
- Reassemble compression spring and depth control knob.

PROPER CARE OF CUTTERS

Get faster and more accurate cutting results by keeping cutters clean and sharp. Remove all accumulated pitch and gum from cutters after each use.

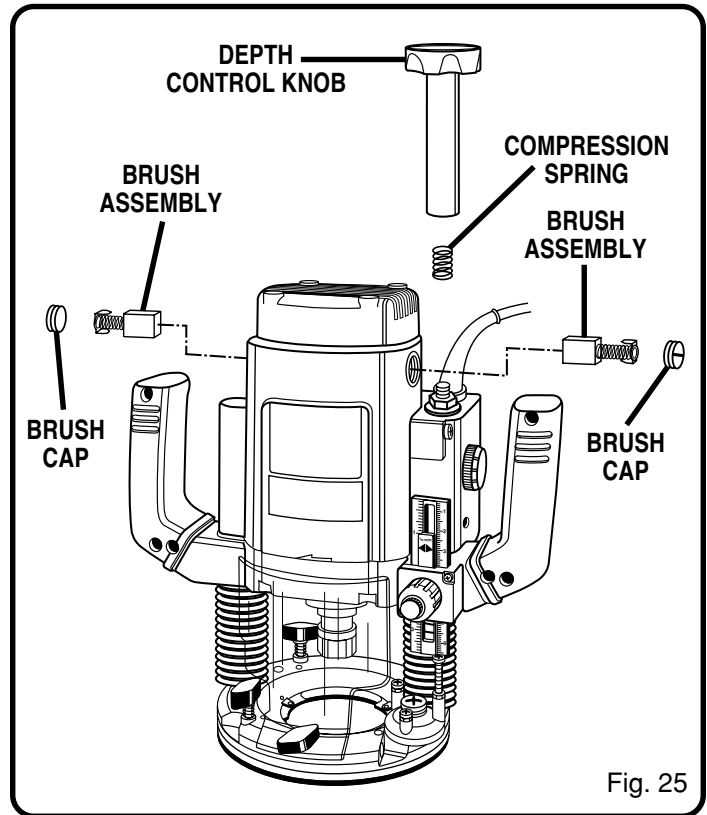

When sharpening cutters, sharpen only the inside of the cutting edge. Never grind the outside diameter. Be sure when sharpening the end of a cutter to grind the clearance angle the same as originally ground.

PROPER CARE OF COLLET

From time to time, it also becomes necessary to clean your collet and collet nut. To do so, simply remove collet nut from collet and clean the dust and chips that have collected. Then return collet nut to its original position. **DO NOT** tighten collet nut on collet without a cutter installed.

LUBRICATION

All of the bearings in this tool are lubricated with a sufficient amount of high grade lubricant for the life of the unit under normal operating conditions. Therefore, no further lubrication is required.

MAINTENANCE

GENERAL

Avoid using solvents when cleaning plastic parts. Most plastics are susceptible to damage from various types of commercial solvents and may be damaged by their use. Use clean cloths to remove dirt, carbon dust, etc.



WARNING:

Do not at any time let brake fluids, gasoline, petroleum-based products, penetrating oils, etc. come in contact with plastic parts. They contain chemicals that can damage, weaken, or destroy plastic.

When electric tools are used on fiberglass boats, sports cars, wallboard, spackling compounds, or plaster, it has been found that they are subject to accelerated wear and possible premature failure, as the fiberglass chips and grindings are highly abrasive to bearings, brushes, commutators, etc. Consequently, it is not recommended that this tool be used for extended work on any fiberglass material, wallboard, spackling compounds, or plaster. During any use on these materials, it is extremely important that the tool is cleaned frequently by blowing with an air jet.



WARNING:

Always wear safety goggles or safety glasses with side shields during power tool operation or when blowing dust. If operation is dusty, also wear a dust mask.

OPTIONAL ACCESSORIES

The following recommended accessories are current and were available at the time this manual was printed:

ITEM NO.	DESCRIPTION
6072483	Template Guide (Non-adaptable) 1/2 in. (13 mm) O.D.
6072493	Template Guide Adapter - Accepts all Ryobi template guides
6072503	Template Guide Adapter - Accepts Porter-Cable, Rockwell, and Black & Decker template guides
6070573	Straight Guide Holder
6150453	Straight Guide (requires straight guide holder #6070573 above)
6072213	1/2 in. (13 mm) to 3/8 in. (10 mm) Bit Adapter
* 6072223	1/2 in. (13 mm) to 1/4 in. (6.4 mm) Bit Adapter
* 6080997	Phillips Flat Head Screws for router table mounting - M8 x 25 - Set of 4
* 6240863	24 mm Wrench

* Included with your router as standard accessories

HELPFUL HINTS

- ✓ Always clamp workpiece securely before routing.
- ✓ A safe operator is one who thinks ahead.
- ✓ Always wear eye protection when routing.
- ✓ Make setup adjustments carefully. Then double check. Measure twice and cut once.
- ✓ Keep cutters clean and properly sharpened.
- ✓ Don't let familiarity make you careless.
- ✓ Study all safety rules and do the job safely.
- ✓ **NEVER** place your hands in jeopardy.
- ✓ Make certain clamps can't loosen while in use.
- ✓ Test difficult setups on scrap—Don't waste lumber.
- ✓ Plan each operation before you begin.
- ✓ Provide for smoother operation by cleaning your router frequently. Shake router or blow with an air jet to remove sawdust buildup.
- ✓ **DO NOT ABUSE POWER TOOLS.** Abusive practices can damage tool as well as workpiece.
- ✓ **THINK SAFETY BY THINKING AHEAD.**

RYOBI® OWNER'S OPERATING MANUAL

Electronic Plunge Router

Heavy Duty Model RE601

Variable Speed / Double Insulated

EXTENSION CORD CAUTION

When using a power tool at a considerable distance from a power source, be sure to use an extension cord that has the capacity to handle the current the tool will draw. An undersized cord will cause a drop in line voltage, resulting in overheating and loss of power. Use the chart to determine the minimum wire size required in an extension cord. Only round jacketed cords should be used.

When working with a tool outdoors, use an extension cord that is designed for outside use. This is indicated by the letters "WA" on the cord's jacket.

Before using any extension cord, inspect it for loose or exposed wires and cut or worn insulation.

**Ampere rating
(on tool data plate) 0-2.0 2.1-3.4 3.5-5.0 5.1-7.0 7.1-12.0 12.1-16.0

Cord Length	Wire Size (A.W.G.)					
25'	16	16	16	16	14	14
50'	16	16	16	14	14	12
100'	16	16	14	12	10	—

⚠ CAUTION: Keep the extension cord clear of the working area. Position the cord so that it will not get caught on workpiece, tools, or other obstructions while you are working with a power tool.

***Used on 12 gauge - 20 amp circuit.*

• SERVICE

Now that you have purchased your tool, should a need ever exist for repair parts or service, simply contact your nearest Ryobi Factory Service Center. Be sure to provide all pertinent facts when you call or visit. Please refer to the Service Center insert or call 1-800-525-2579 in the United States or 1-800-265-6778 in Canada for your nearest Factory or Authorized Service Center.

• MODEL NO.

The model number of your tool will be found on a plate attached to the motor housing. Please record the model number and serial number in the space provided below.

- MODEL NUMBER RE601
- SERIAL NUMBER _____

RYOBI AMERICA CORPORATION

5201 Pearman Dairy Road Anderson SC 29625-8950
 Post Office Box 1207 Anderson SC 29622-1207
 Phone 1-800-525-2579

RYOBI CANADA INC.

P.O. Box 910
 Cambridge, Ontario N1R 6K2
 Phone 1-800-265-6778