

**RYOBI R162K  
ROUTER  
MODEL NOS.  
R1801M, R181FB**

**REPAIR SHEET**

# RYOBI ROUTER MOTOR - MODEL NUMBER R1801M

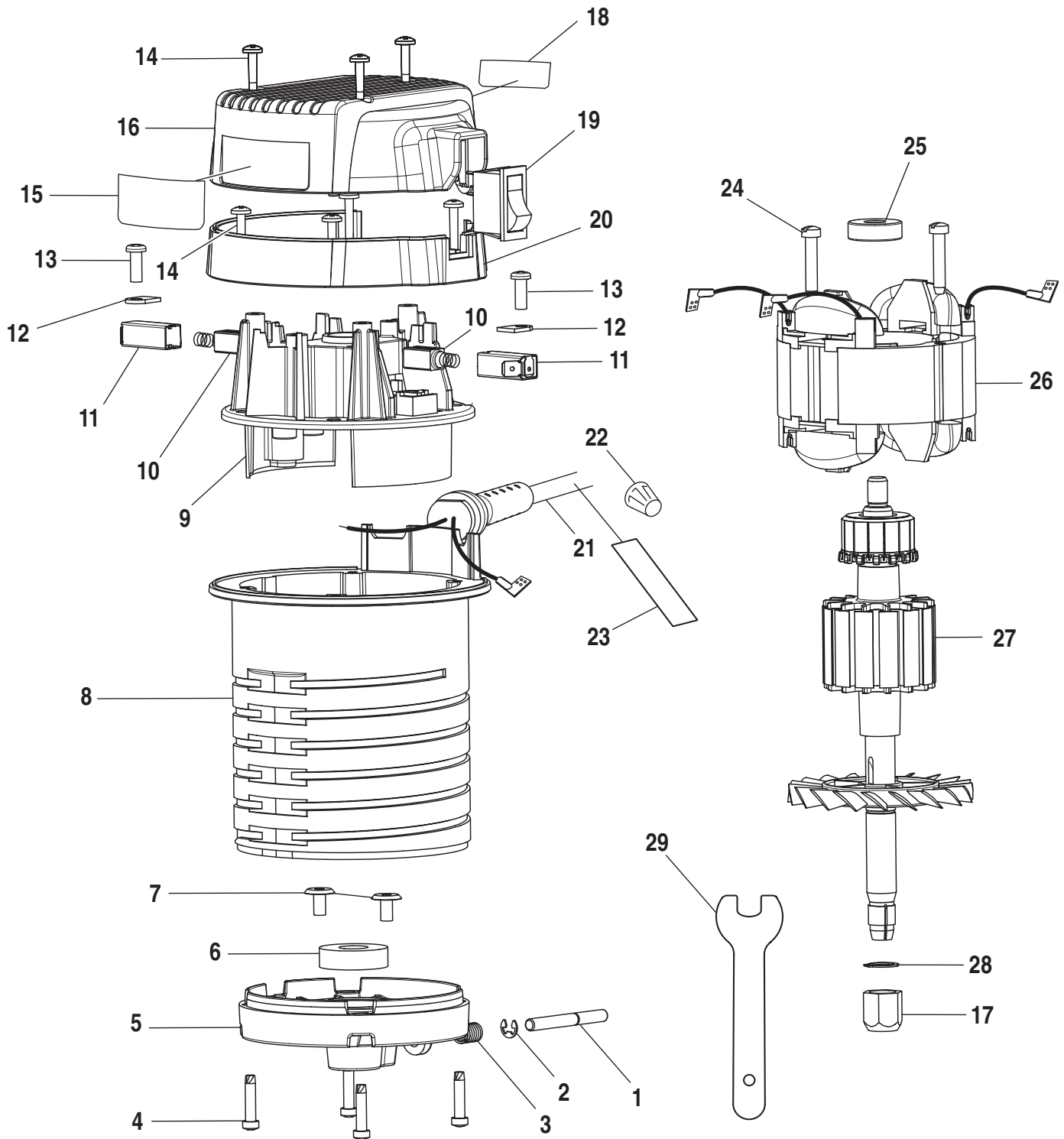

**WARNING:** Improper repair of a double insulated tool can result in damages to the double insulation system possibly causing electrical shock or electrocution. Any repairs requiring disassembly of your tool requires safety testing and should only be performed by a Ryobi Authorized Service Center. For the service center nearest you call 1-800-525-2579.

## RYOBI ROUTER MOTOR – MODEL NUMBER R1801M

The model number will be found on a plate attached to the motor housing. Always mention the model number in all correspondence regarding your **ROUTER** or when ordering repair parts.

### PARTS LIST

KEY NO.	PART NUMBER	DESCRIPTION	QTY.
1	982959-003	SHAFT LOCK PIN .....	1
2	982899-014	E-RING .....	1
3	982716-001	SHAFT LOCK SPRING .....	1
4	643526-006	* SCREW (8-18 X 3/4 in. PAN HD.).....	4
5	982973-003	BEARING FRAME .....	1
6	989919-004	BALL BEARING .....	1
7	998401-001	* SCREW (10-32 x 3/8 in. WAFER HD.).....	2
8	982951-001	MOTOR HOUSING.....	1
9	982950-001	TOP BEARING PLATE .....	1
10	610784-064	BRUSH W/SPRING .....	2
11	611686-003	BRUSH TUBE.....	2
12	617800-002	BRUSH TUBE CLAMP .....	2
13	968702-007	* SCREW (8-16 X 1/2 in. PAN HD.).....	2
14	617966-031	* SCREW (8-10 X 3/4 in. PAN HD.).....	7
15	982722-001	LOGO PLATE.....	1
16	983931-001	UPPER TOP CAP .....	1
17	989985-003	COLLET NUT.....	1
18	983959-001	DATA PLATE .....	1
19	982379-002	ROCKER SWITCH.....	1
20	983304002	LOWER TOP CAP .....	1
21	970777-031	CORD .....	1
22	623173-006	WIRE NUT .....	1
23	983462-001	CORD TAG .....	1
24	983048-171	* SCREW (10-16 X 1 in. FIL. HD.).....	2
25	986294-003	BALL BEARING .....	1
26	982729-006	FIELD ASSEMBLY .....	1
27	982976-001	ARMATURE .....	1
28	622167-012	RETAINING RING .....	1
29	983012-001	WRENCH.....	1
	983000-165	OPERATOR'S MANUAL	
	983000-165R	REPAIR SHEET	
	05-03-04		

**\* Standard Hardware Item – May Be Purchased Locally**

RYOBI ROUTER FIXED BASE – MODEL NUMBER R181FB

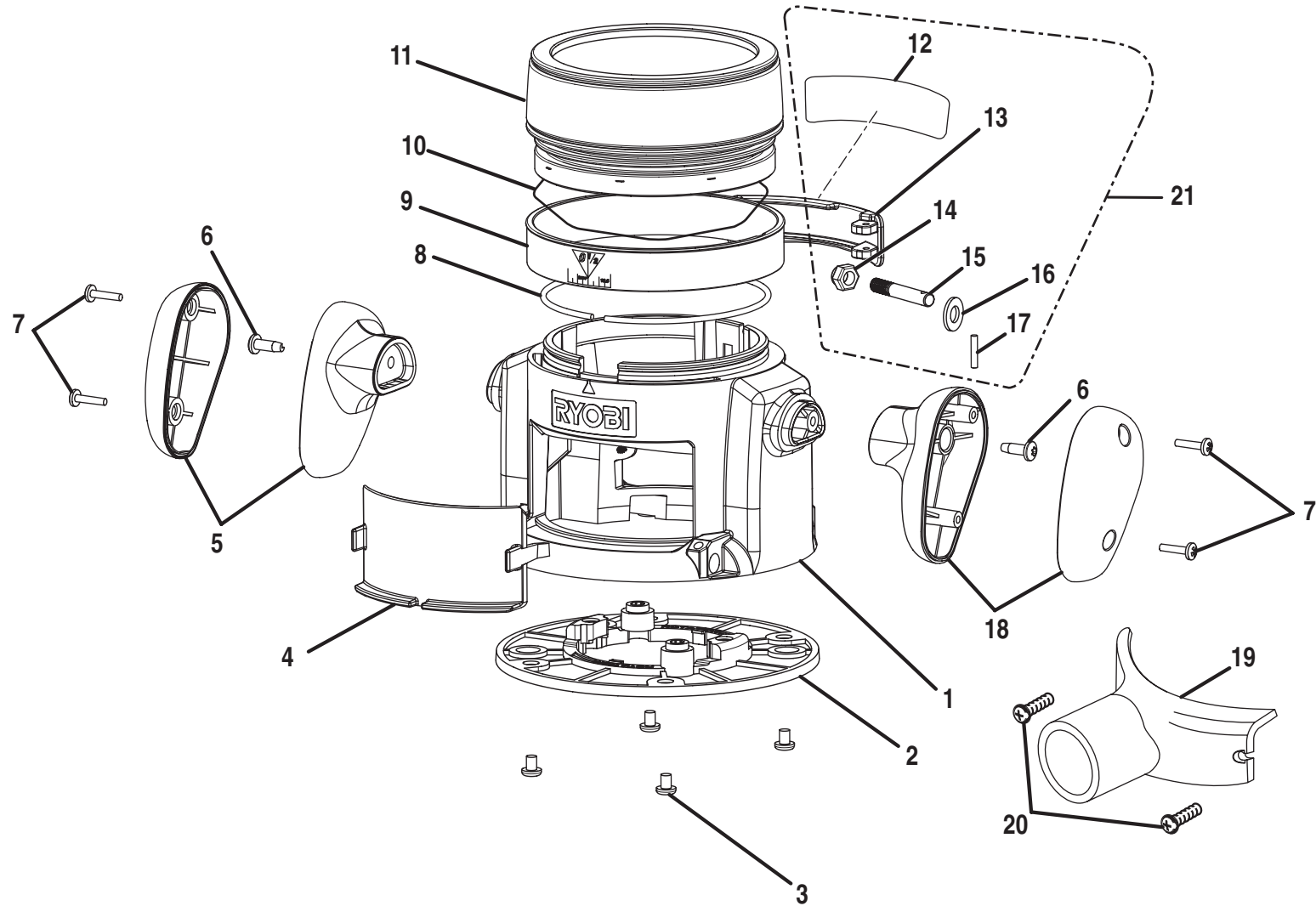

**WARNING:** Improper repair of a double insulated tool can result in damages to the double insulation system possibly causing electrical shock or electrocution. Any repairs requiring disassembly of your tool requires safety testing and should only be performed by a Ryobi Authorized Service Center. For the service center nearest you call 1-800-525-2579.

## RYOBI ROUTER FIXED BASE – MODEL NUMBER R181FB

The model number will be found on a plate attached to the base. Always mention the model number in all correspondence regarding your **ROUTER** or when ordering repair parts.

### PARTS LIST

KEY NO.	PART NUMBER	DESCRIPTION	QTY.
1	983305-201	BASE W/PIN.....	1
2	983306-201	SUBBASE W/INSERTS.....	1
3	998586-001	* SCREW (10-32 X 1/4 in. PAN HD.).....	4
4	983308-001	CHIP SHIELD.....	1
5	982991-001	HANDLE ASSEMBLY.....	1
6	983699-128	* SCREW (10-24 X 9/16 in. TORX PAN HD.).....	2
7	617966-030	* SCREW (8-10 X 5/8 in. PAN HD.).....	4
8	983689-001	SPLINE.....	1
9	983422-001	ZERO RESET RING.....	1
10	984673-001	RESET RING SPRING.....	1
11	983307-001	DEPTH ADJUSTMENT RING.....	1
12	983463-001	INFORMATION PLATE.....	1
13	983451-201	LEVER W/INFORMATION PLATE.....	1
14	703477-057	* HEX LOCK NUT (1/4-20).....	1
15	982972-001	LEVER PIN.....	1
16	706382-357	WASHER.....	1
17	982948-032	NEEDLE ROLLER PIN.....	1
18	983474-001	RIGHT HANDLE SET.....	1
19	983311-001	DUST NOZZLE.....	1
20	643115-005	* SCREW (6-32 x 3/8 in. PAN HD.).....	2
21	974785-003	LOCK LEVER REPAIR KIT (INCLUDES KEY NOS. 12-17).....	1

\* Standard Hardware Item – May Be Purchased Locally