

# RYOBI ROUTER – MODEL NUMBERS R161

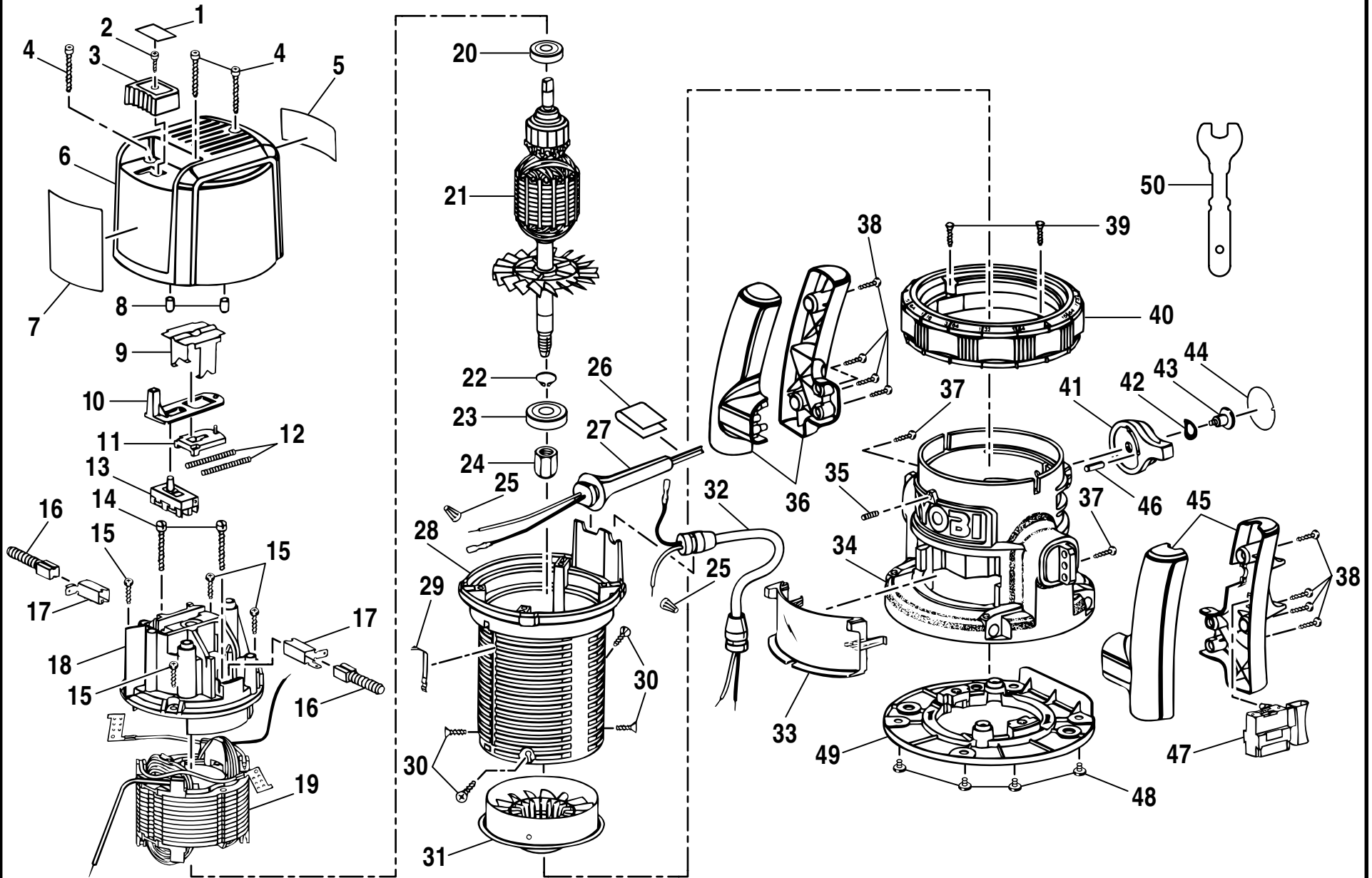

**WARNING:** Improper repair of a double insulated tool can result in damages to the double insulation system possibly causing electrical shock or electrocution. Any repairs requiring disassembly of your tool requires safety testing and should only be performed by a Ryobi Authorized Service Center. For the service center nearest you call 1-800-525-2579 in the United States or 1-866-897-9624 in Canada.

## RYOBI ROUTER – MODEL NUMBERS R161

The model number will be found on a plate attached to the motor housing. Always mention the model number in all correspondence regarding your **ROUTER** or when ordering repair parts.

### PARTS LIST

Key No.	Part Number	Description	Quan.	Key No.	Part Number	Description	Quan.
1	974323-003	LABEL.....	1	28	973657-001	MOTOR HOUSING .....	1
2	999053-003	SCREW (#5-10 X 1/2 IN. FIL. HD.).....	1	29	973688-001	POINTER .....	1
3	973671-003	ACTUATOR BUTTON .....	1	30	612556-003	SCREW (#8-18 X 9/16 IN. FIL. HD. T.C.) .....	4
4	989592-002	SCREW (#8-10 X 1-3/8 IN. FIL. HD.).....	3	31	973659-001	LOWER BEARING PLATE .....	1
5	982747-001	DATA PLATE .....	1	32	973975-002	POWER HANDLE CORD .....	1
6	973658-001	END CAP .....	1	33	973672-002	CHIP SHIELD .....	1
7	982749-001	LOGO PLATE .....	1	34	974908-004	BASE .....	1
8	617834-001	BUMPER .....	2	35	726676-002	SET SCREW (#8-32 X 7/16 IN. FLAT POINT) ...	1
9	989573-001	RETAINER CLIP .....	1	36	975062-001	AUXILIARY HANDLE .....	1
10	973679-003	SHAFT LOCK LEVER .....	1	37	968700-009	SCREW (#6-19 X 5/8 IN. PAN HD.).....	2
11	612858-001	SLIDE LOCK ASSEMBLY .....	1	38	610120-005	SCREW (#6-10 X 3/4 IN. PAN HD.).....	8
12	974951-001	SPRING .....	2	39	974516-001	SCREW (#4-40 X 3/4 IN. PAN HD.).....	2
13	968303-098	SWITCH .....	1	40	974239-004	RING ASSEMBLY .....	1
14	714096-807	SCREW (#10-16 X 1 IN. FIL. HD. T.F.) .....	2	41	973669-001	DEPTH LOCK LEVER .....	1
15	616081-014	SCREW (#8-18 X 11/16 IN. PAN HD.).....	4	42	622347-020	WASHER .....	1
16	968304-026	BRUSH ASSEMBLY .....	2	43	970712-002	SHOULDER SCREW (#10-32 X 5/16 IN. PAN HD.) .....	1
17	611686-003	BRUSH TUBE .....	2	44	973689-001	SHAFT LOCK LABEL .....	1
18	612848-007	TOP BEARING PLATE.....	1	45	975063-001	POWER HANDLE .....	1
19	968307-119	FIELD.....	1	46	623924-007	NEEDLE ROLLER .....	1
20	968305-010	BALL BEARING (NTN#608ZZ/1E).....	1	47	968303-046	SWITCH TRIGGER .....	1
21	968306-125	ARMATURE .....	1	48	998586-001	SCREW (#10-32 X 1/4 IN. PAN HD.).....	4
22	622167-012	RETAINING RING .....	1	49	973668-002	SUBBASE .....	1
23	968305-020	BALL BEARING (NTN#6001LLBC3/1E) .....	1	50	989935-006	WRENCH.....	1
24	989985-003	1/4 IN. COLLET NUT .....	1		972000-891	OWNER'S MANUAL	
25	623173-005	WIRE NUT .....	3		9-01		
26	973252-001	CORD LABEL .....	1				
27	970105-020	CORD .....	1				