

RYOBI OPERATOR'S MANUAL 5-1/2 in. CORDLESS CIRCULAR SAW MODEL NO. R10630

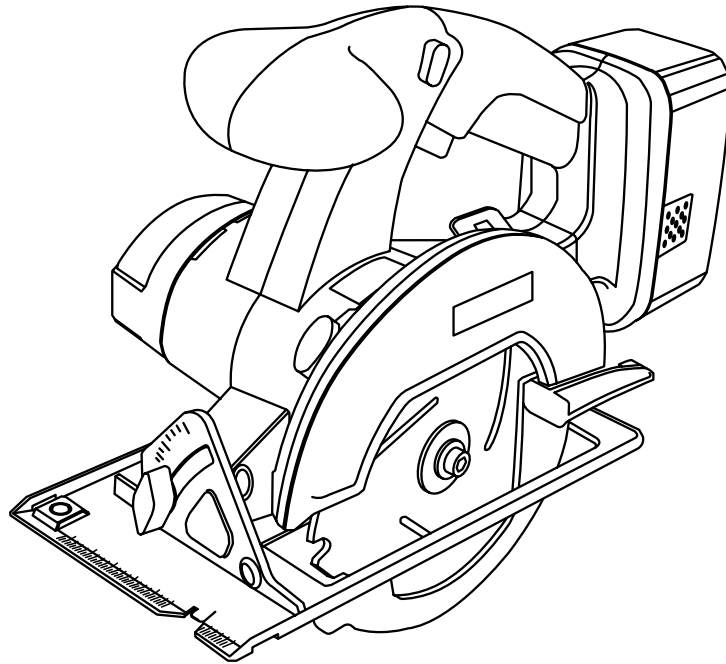

| SPECIFICATIONS: | |
|------------------------|----------------------|
| Blade Diameter | 5-1/2 in. (140 mm) |
| Blade Arbor | 3/8 in. (10 mm) |
| Cutting Depth at 0° | 1-9/16 in. (40 mm) |
| Cutting Depth at 45° | 1-1/8 in. (29 mm) |
| No Load Speed | 4,200 RPM |
| Motor | 18 Volt DC |
| Charge Rate | 1 Hour |
| Charger Rating | 120 Volts, 60 Hz, AC |

THANK YOU FOR BUYING A RYOBI CORDLESS CIRCULAR SAW.

Your new cordless circular saw has been engineered and manufactured to Ryobi's high standard for dependability, ease of operation, and operator safety. Properly cared for, it will give you years of rugged, trouble-free performance.

⚠ CAUTION: Carefully read through this entire operator's manual before using your new cordless circular saw.

Pay close attention to the Rules for Safe Operation, Warnings, and Cautions. If you use your cordless circular saw properly and only for what it is intended, you will enjoy years of safe, reliable service.

Thank you again for buying Ryobi tools.

SAVE THIS MANUAL FOR FUTURE REFERENCE

TABLE OF CONTENTS

| | |
|--|------|
| ■ Table of Contents | 2 |
| ■ Accessories | 2 |
| ■ Unpacking | 2 |
| ■ Rules For Safe Operation | 3-5 |
| A. Important Safety Rules For Battery Tools | 4 |
| B. Important Safety Instructions For Charger | 4 |
| C. Important Safety Instructions For Circular Saws | 5 |
| ■ Features | 6-7 |
| ■ Operation | 8-18 |
| ■ Maintenance | 19 |
| ■ Battery Pack Removal and Preparation For Recycling | 19 |
| ■ Parts Ordering / Service | 20 |



Look for this symbol to point out important safety precautions. It means attention!!!
Your safety is involved.

ACCESSORIES

The following recommended accessories are current and were available at the time this manual was printed.

- 5-1/2 in. (140 mm) Thin Kerf Blade

UNPACKING

Your circular saw has been shipped completely assembled except for the blade. Inspect it carefully to make sure no breakage or damage has occurred during shipping. If any parts are damaged or missing, contact your nearest Ryobi Authorized Service Center to obtain replacement parts before attempting to operate saw. A blade, blade wrench, and this operator's manual are also included.



WARNING:

If any parts are missing, do not operate this tool until the missing parts are replaced. Failure to do so could result in possible serious personal injury.



WARNING:



The operation of any power tool can result in foreign objects being thrown into your eyes, which can result in severe eye damage. Before beginning power tool operation, always wear safety goggles or safety glasses with side shields and a full face shield when needed. We recommend Wide Vision Safety Mask for use over eyeglasses or standard safety glasses with side shields.

RULES FOR SAFE OPERATION

The purpose of safety symbols is to attract your attention to possible dangers. The safety symbols, and the explanations with them, deserve your careful attention and understanding. The safety warnings do not by themselves eliminate any danger. The instructions or warnings they give are not substitutes for proper accident prevention measures.

SYMBOL MEANING



SAFETY ALERT SYMBOL:

Indicates danger, warning, or caution. May be used in conjunction with other symbols or pictographs.



DANGER: Failure to obey a safety warning will result in serious injury to yourself or to others. Always follow the safety precautions to reduce the risk of fire, electric shock and personal injury.



WARNING: Failure to obey a safety warning can result in serious injury to yourself or to others. Always follow the safety precautions to reduce the risk of fire, electric shock and personal injury.



CAUTION: Failure to obey a safety warning may result in property damage or personal injury to yourself or to others. Always follow the safety precautions to reduce the risk of fire, electric shock and personal injury.

NOTE:

Advises you of information or instructions vital to the operation or maintenance of the equipment.



WARNING:

Do not attempt to operate this tool until you have read thoroughly and understand completely all instructions, safety rules, etc. contained in this manual. Failure to comply can result in accidents involving fire, electric shock, or serious personal injury. Save operator's manual and review frequently for continuing safe operation, and instructing others who may use this tool.

READ ALL INSTRUCTIONS

- **KNOW YOUR POWER TOOL.** Read operator's manual carefully. Learn its applications and limitations as well as the specific potential hazards related to this tool.
- **GUARD AGAINST ELECTRICAL SHOCK** by preventing body contact with grounded surfaces. For example: Pipes, radiators, ranges, refrigerator enclosures.
- **KEEP WORK AREA CLEAN.** Cluttered areas and benches invite accidents.
- **AVOID DANGEROUS ENVIRONMENT.** Don't use power tool in damp or wet locations or expose to rain. Keep work area well lit.
- **KEEP CHILDREN AND VISITORS AWAY.** All visitors should wear safety glasses and be kept a safe distance from work area. Do not let visitors contact tool or extension cord.
- **STORE IDLE TOOLS.** When not in use tools should be stored in a dry and high or locked-up place - out of the reach of children.
- **DON'T FORCE TOOL.** It will do the job better and safer at the rate for which it was designed.
- **USE RIGHT TOOL.** Don't force small tool or attachment to do the job of a heavy duty tool. Don't use tool for purpose not intended - for example - A circular saw should never be used for cutting tree limbs or logs.
- **WEAR PROPER APPAREL.** Do not wear loose clothing or jewelry that can get caught in tool's moving parts and cause personal injury. Rubber gloves and nonskid footwear are recommended when working outdoors. Wear protective hair covering to contain long hair and keep it from being drawn into nearby air vents.
- **ALWAYS WEAR SAFETY GLASSES.** Everyday eye-glasses have only impact-resistant lenses; they are **NOT** safety glasses.
- **PROTECT YOUR LUNGS.** Wear a face mask or dust mask if operation is dusty.
- **PROTECT YOUR HEARING.** Wear hearing protection during extended periods of operation.
- **SECURE WORK.** Use clamps or a vise to hold work. It's safer than using your hand and it frees both hands to operate tool.
- **DON'T OVERREACH.** Keep proper footing and balance at all times. Do not use while standing on a ladder or unstable support.
- **MAINTAIN TOOLS WITH CARE.** Keep tools sharp at all times, and clean for best and safest performance. Follow instructions for lubricating and changing accessories.

RULES FOR SAFE OPERATION (Continued)

- **REMOVE ADJUSTING KEYS AND WRENCHES.** Form habit of checking to see that keys and adjusting wrenches are removed from tool before turning it on.
- **NEVER USE IN AN EXPLOSIVE ATMOSPHERE.** Normal sparking of the motor could ignite flammable liquids, gases, or fumes.
- **KEEP HANDLES DRY, CLEAN, AND FREE FROM OIL AND GREASE.** Always use a clean cloth when cleaning. Never use brake fluids, gasoline, petroleum-based products or any strong solvents to clean your tool.
- **STAY ALERT.** Watch what you are doing and use common sense. Do not operate tool when you are tired. Do not rush.
- **CHECK DAMAGED PARTS.** Before further use of the tool, a guard or other part that is damaged should be carefully checked to determine that it will operate properly and perform its intended function. Check for alignment of moving parts, binding of moving parts, breakage of parts, mounting, and any other conditions that may affect its operation. A guard or other part that is damaged should be properly repaired or replaced by an authorized service center unless indicated elsewhere in this operator's manual.
- **DO NOT USE TOOL IF SWITCH DOES NOT TURN IT ON AND OFF.** Have defective switches replaced by an authorized service center.
- **DRUGS, ALCOHOL, MEDICATION.** Do not operate tool while under the influence of drugs, alcohol, or any medication.
- **CUTTING INTO ELECTRICAL WIRING IN WALLS AND FLOORS CAN CAUSE THE BLADE AND METAL PARTS TO BECOME ELECTRICALLY LIVE.** Do not touch metal parts when cutting into walls and floors; grasp only the insulated handle(s) provided on the tool. Make sure hidden electrical wiring, water pipes, and mechanical hazards are not in the blade path when cutting into a wall or floor.
- **INSPECT FOR** and remove all nails from lumber before cutting.

IMPORTANT SAFETY RULES FOR BATTERY TOOLS

- Battery tools do not have to be plugged into an electrical outlet; therefore, they are always in an operating condition. Be aware of possible hazards when carrying your battery tool, when making adjustments to it, or when changing accessories.
- **USE ONLY THE CHARGER PROVIDED WITH YOUR BATTERY TOOL.** Do not substitute any other charger. Use of another charger could cause batteries to explode causing possible serious injury.
- **DO NOT PLACE BATTERY TOOLS OR THEIR BATTERIES NEAR FIRE OR HEAT.** They may explode.

- **DO NOT CHARGE BATTERY TOOL IN A DAMP OR WET LOCATION.**
- Your battery tool should be charged in a location where the temperature is more than 50°F but less than 100°F.
- Under extreme usage or temperature conditions, battery leakage may occur. If liquid comes in contact with your skin, wash immediately with soap and water, then neutralize with lemon juice or vinegar. If liquid gets in your eyes, flush them with clean water for at least 10 minutes, then seek immediate medical attention.
- If carrying your battery tool at your side, make sure it is not running and your finger is not on the switch. Avoid accidental starting.
- **SECURE WORK** before applying power. **NEVER** hold workpiece in your hand or across your legs.
- **WHEN SERVICING USE ONLY IDENTICAL REPLACEMENT PARTS.**

IMPORTANT SAFETY INSTRUCTIONS FOR CHARGER

- **SAVE THESE INSTRUCTIONS.** This manual contains important safety and operating instructions for battery charger part numbers 1400667 and 1400677.
- Before using battery charger, read all instructions and cautionary markings in this manual, on battery charger, and product using battery charger.



WARNING:

To reduce risk of injury, charge only nickel-cadmium type rechargeable batteries. Other types of batteries may burst causing personal injury and damage.

- Do not expose charger to rain or snow.
- Use of an attachment not recommended or sold by the battery charger manufacturer may result in a risk of fire, electric shock, or injury to persons.
- To reduce risk of damage to charger body and cord, pull by charger body rather than cord when disconnecting charger.
- Make sure cord is located so that it will not be stepped on, tripped over, or otherwise subjected to damage or stress.
- An extension cord should not be used unless absolutely necessary. Use of improper extension cord could result in a risk of fire and electric shock. If extension cord must be used, make sure:
 - a. That pins on plug of extension cord are the same number, size and shape as those of plug on charger.
 - b. That extension cord is properly wired and in good electrical condition; and

RULES FOR SAFE OPERATION (Continued)

- c. That wire size is large enough for AC ampere rating of charger as specified below:

Cord Length (Feet) 25' 50' 100'

Cord Size (AWG) 16 16 16

NOTE: AWG = American Wire Gage

- **DO NOT OPERATE CHARGER WITH A DAMAGED CORD OR PLUG.** If damaged, have replaced immediately by a qualified serviceman.
- Do not operate charger if it has received a sharp blow, been dropped, or otherwise damaged in any way; take it to a qualified serviceman.
- Do not disassemble charger; take it to a authorized serviceman when service or repair is required. Incorrect reassembly may result in a risk of electric shock or fire.
- To reduce risk of electric shock, unplug charger from outlet before attempting any maintenance or cleaning. Turning off controls will not reduce this risk.
- Do not use charger outdoors.
- Disconnect charger from power supply when not in use.

IMPORTANT SAFETY INSTRUCTIONS FOR CIRCULAR SAWS

- **KEEP GUARDS IN PLACE AND IN WORKING ORDER.** Never wedge or tie lower blade guard open. Check operation of lower blade guard before each use. Do not use if lower blade guard does not close briskly over saw blade.

WARNING:

If saw is dropped, lower blade guard or bumper may be bent, restricting full return. If lower blade guard or bumper becomes bent or damaged, replace them before reuse.

- **KEEP BLADES CLEAN AND SHARP.** Sharp blades minimize stalling and kickback.
- **KEEP HANDS AWAY FROM CUTTING AREA.** Keep hands away from blade. Do not reach underneath work while blade is rotating. Do not attempt to remove cut material when blade is moving.

WARNING:

Blades coast after turn off.

- **USE RIP FENCE.** Always use a fence or straight edge guide when ripping.
- **SUPPORT LARGE PANELS.** To minimize the risk of blade pinching and kickback, always support large panels as shown in Figure 11, Page 12. When cutting

operation requires the resting of the saw on the workpiece, the saw should be rested on the larger portion and the smaller piece cut off.

■ LOWER BLADE GUARD.

WARNING:

If lower blade guard must be raised to make a cut, always raise it with the retracting handle to avoid serious injury. See Figure 22, Page 17.

- **GUARD AGAINST KICKBACK.** Kickback occurs when the saw stalls rapidly and is driven back towards the operator. Release switch immediately if blade binds or saw stalls. Don't remove saw from work during a cut while the blade is moving. See Pages 12 and 13.
- **BEFORE MAKING A CUT, BE SURE THE DEPTH AND BEVEL ADJUSTMENTS ARE TIGHT.**
- **USE ONLY CORRECT BLADES.** Do not use blades with incorrect size holes. Never use blade washers or bolts that are defective or incorrect. The maximum blade capacity of your saw is 5-1/2 inches (140 mm).
- **NEVER** touch the blade or other moving parts during use.
- **NEVER** start a saw when its blade is touching the workpiece.
- **NEVER** lay a tool down before its moving parts have come to a complete stop.
- **SAVE THESE INSTRUCTIONS.** Refer to them frequently and use them to instruct others who may use this tool. If you loan someone this tool, loan them these instructions also.

WARNING:

Some dust created by power sanding, sawing, grinding, drilling, and other construction activities contains chemicals known to cause cancer, birth defects or other reproductive harm. Some examples of these chemicals are:

- lead from lead-based paints,
- crystalline silica from bricks and cement and other masonry products, and
- arsenic and chromium from chemically-treated lumber.

Your risk from these exposures varies, depending on how often you do this type of work. To reduce your exposure to these chemicals: work in a well ventilated area, and work with approved safety equipment, such as those dust masks that are specially designed to filter out microscopic particles.

SAVE THESE INSTRUCTIONS

FEATURES

KNOW YOUR CORDLESS CIRCULAR SAW

See Figure 1.

Before attempting to use any tool, familiarize yourself with all operating features and safety requirements.

Features include easily operated bevel cut and depth of cut adjustment mechanisms; positive 0° bevel stop; spindle lock; and blade wrench storage.

APPLICATIONS

(Use only for the purpose listed below)

- Cutting all types of wood products (lumber, plywood, paneling).

SWITCH

Your saw is equipped with a lock-off button which reduces the possibility of accidental starting. The lock-off button is located on the handle above the switch trigger. You must depress the lock-off button in order to pull the switch trigger. The lock resets each time the trigger is released.

NOTE: You can depress the lock-off button from either the left or right side.

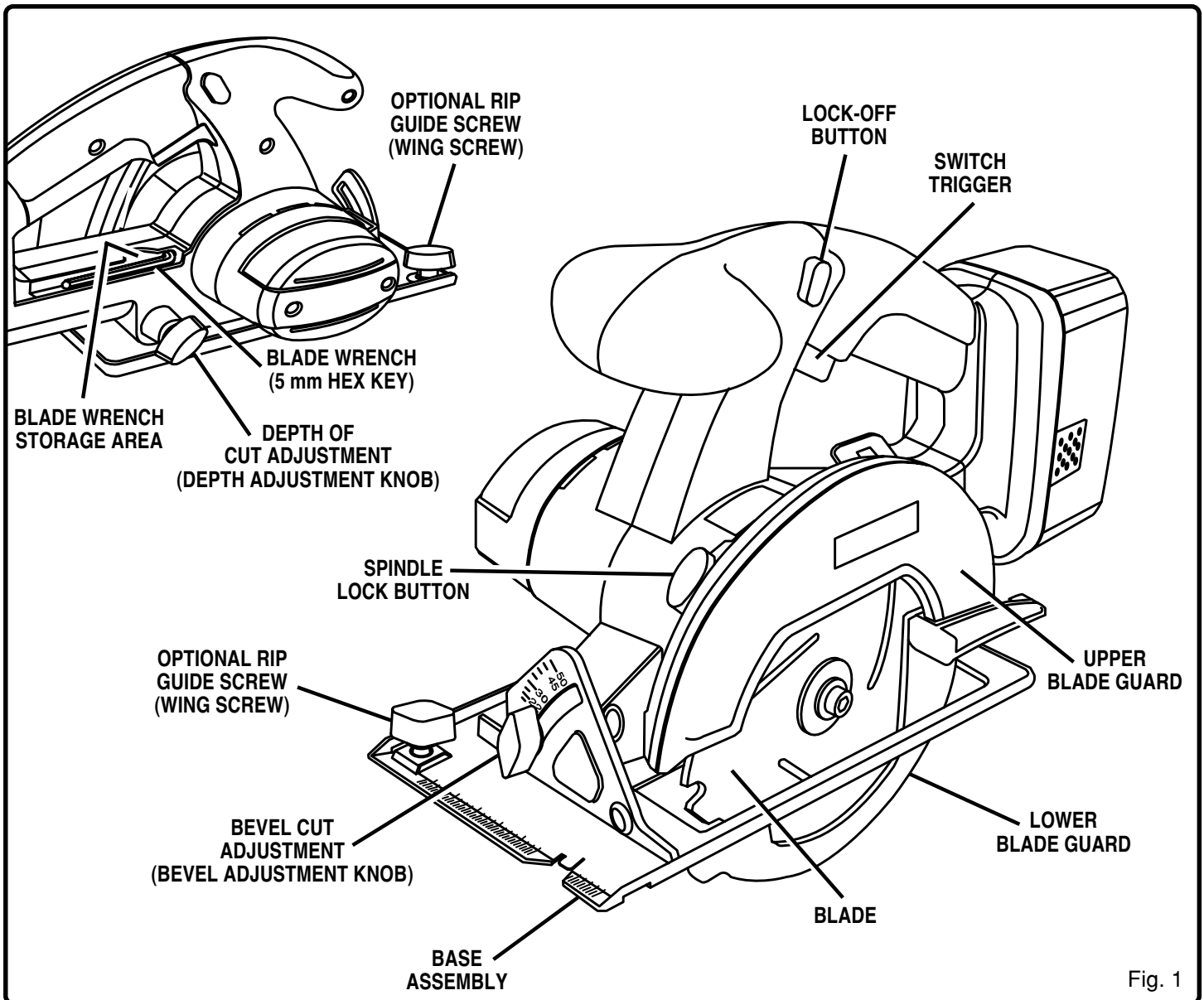
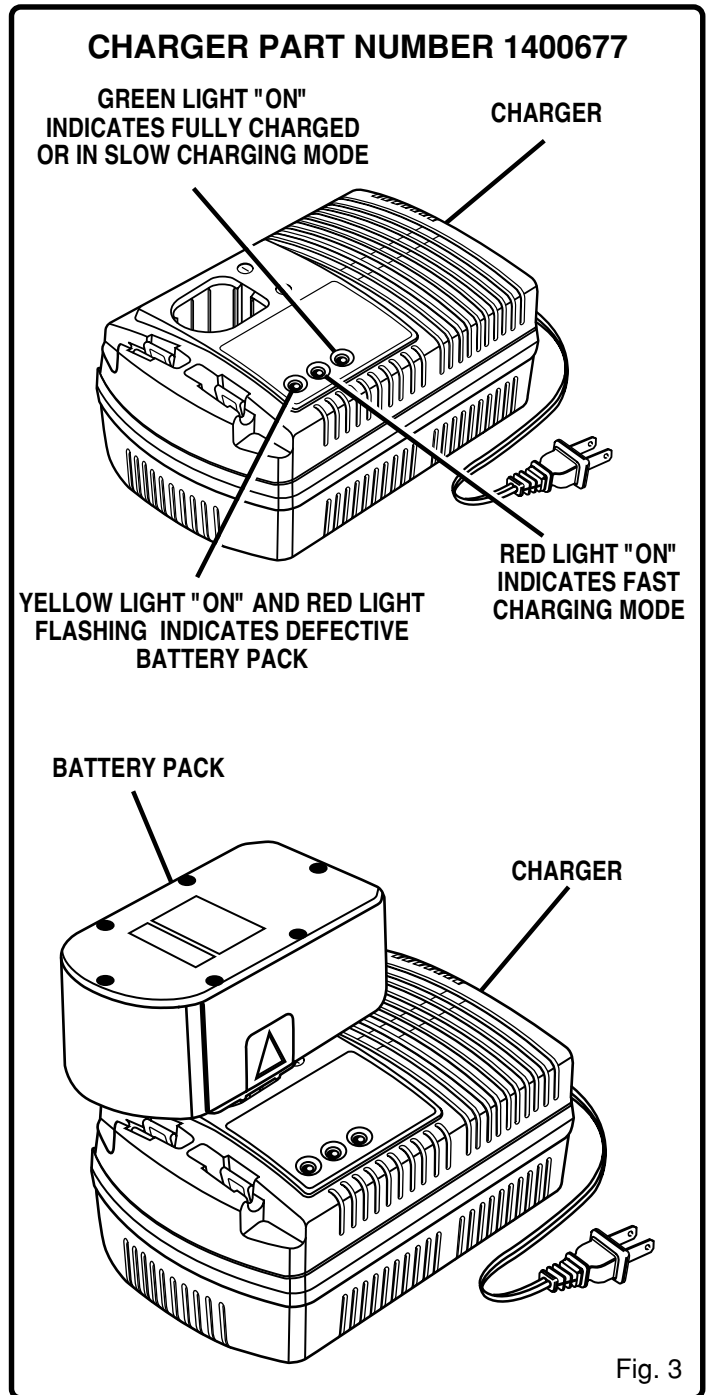
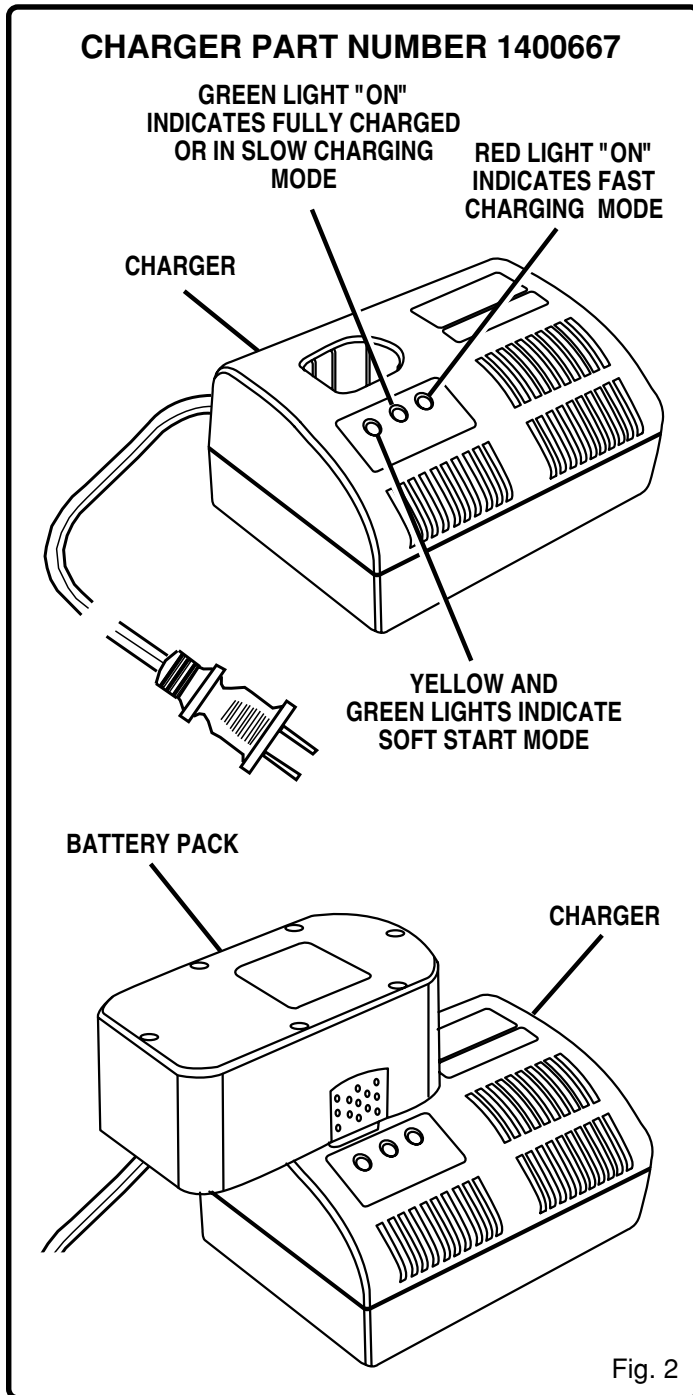

Fig. 1

FEATURES

IMPORTANT CHARGER INFORMATION

The battery pack for your Circular Saw can be charged with charger part number 1400667 or 1400677. As shown below in figures 2 and 3, the difference in these chargers is the LED function. Before using your charger to charge battery pack, it is extremely important that you determine the part number of your charger. Then familiarize yourself with the LED function of the charger you have. The part number will be found on a plate located on the bottom of your charger.



OPERATION



WARNING:

Always wear safety goggles or safety glasses with side shields when operating tools. Failure to do so could result in objects being thrown into your eyes, resulting in possible serious injury.



WARNING:

Do not allow familiarity with your circular saw to make you careless. Remember that a careless fraction of a second is sufficient to inflict severe injury.

CHARGING BATTERY PACK WITH CHARGER PART NUMBER 1400667

The battery pack for this tool has been shipped in a low charge condition to prevent possible problems. Therefore, you should charge it until light on front of charger changes from red to green.

NOTE: Batteries will not reach full charge the first time they are charged. Allow several cycles (cutting followed by recharging) for them to become fully charged.

TO CHARGE

- Connect charger to power supply.
- Charge battery pack only with the charger provided.
- **Make sure power supply is normal house voltage, 120 volts, 60 Hz, AC only.**
- Connect charger to power supply.
- Place battery pack in charger aligning raised rib in charger with groove in battery pack.
- Press down on battery pack to be sure contacts on battery pack engage properly with charger contacts.
- Normally, the yellow and green lights on charger will come on. This indicates charger is in soft start mode and should switch to fast charge mode within 5 minutes. When charger is in fast charge mode the red light will come on. If after a period of 15 minutes the yellow and green lights remain on, remove battery pack, wait 1 minute and reinsert battery pack in charger. If the yellow and green lights continue to remain on after an additional 15 minutes, the battery pack is damaged and will not accept a charge. Return battery pack to your nearest Ryobi Authorized Service Center for checking or replacing.
- When your battery pack becomes fully charged, the red light will turn **OFF** and the green light will turn **ON**.
- After normal usage, 1 hour of charging time is required to be

fully charged. A minimum charge time of 1-1/2 hours is required to recharge a completely discharged tool.

- The battery pack will become slightly warm to the touch while charging. This is normal and does not indicate a problem.
- **Do not** place charger in an area of extreme heat or cold. It will work best at normal room temperature.
- When the batteries become fully charged, unplug your charger from power supply and remove the battery pack.

LED FUNCTION OF CHARGER

LED WILL BE LIGHTED TO INDICATE STATUS OF CHARGER AND BATTERY PACK:

- Red LED Lighted = Fast Charging Mode.
- Green LED Lighted = Fully Charged Or In Slow Charging Mode To Maintain Battery Pack.
- Yellow and Green LED Lighted = Soft Start Mode, or After 1/2 Hour Equals Hot or Defective Battery Pack.

IMPORTANT INFORMATION FOR RECHARGING HOT BATTERIES USING CHARGER PART NUMBER 1400667

See Figure 2.

When using your circular saw continuously, the batteries in your battery pack will become hot. You should let a hot battery pack cool down for approximately 30 minutes before attempting to recharge. When the battery pack becomes discharged and is hot, this will cause the yellow and green lights on your battery charger to come on instead of the red light. The yellow and green lights indicate soft start mode and will switch to green only, indicating slow charge mode. The red light indicates fast charge mode, 1 hour charge time. The green light indicates slow charge mode, requiring overnight charging for batteries to reach full charge. If the green light comes on after letting battery pack cool down, remove it from charger for additional cooling.

Once the battery pack cools down, it will recharge battery pack in fast charging mode as normal.

Do not leave a hot battery pack in charger until it cools down. The green light will not go off when battery pack cools. If fast charge mode is desired, you must physically remove a hot battery pack from the charger, let it cool, then place it back in charger after it has cooled down.

NOTE: This situation only occurs when continuous use of your saw causes the batteries to become hot. **It does not occur under normal circumstances.** Refer to "**CHARGING BATTERY PACK WITH CHARGER PART NUMBER 1400667**" for normal recharging of batteries. If the charger does not charge your battery pack under normal circumstances, return **both** the battery pack and charger to your nearest Ryobi Authorized Repair Center for electrical check.

OPERATION

CHARGING BATTERY PACK WITH CHARGER PART NUMBER 1400677

The battery pack for this tool has been shipped in a low charge condition to prevent possible problems. Therefore, you should charge it prior to use.

NOTE: Batteries will not reach full charge the first time they are charged. Allow several cycles (cutting followed by recharging) for them to fully charge.

TO CHARGE

- Charge battery pack only with the charger provided.
- **Make sure power supply is normal house voltage, 120 volts, 60 Hz, AC only.**
- Connect charger to power supply.
- Place battery pack in charger aligning raised rib in charger with groove in battery pack.
- Press down on battery pack to be sure contacts on battery pack engage properly with charger contacts.
- Red light should turn on. Red light indicates fast charging mode.

If red light is flashing, this indicates battery pack is deeply discharged or hot.

If battery pack is hot, red light should become steady after battery pack has cooled down.

If battery pack is deeply discharged, red light should become steady after voltage has increased, normally within 30 minutes.

If after one hour red light is still flashing, this indicates a defective battery pack and should be replaced.

Green light on indicates battery pack is fully charged or in slow charging mode to maintain battery pack charge.

Yellow light on and red light flashing indicates defective battery pack. Return battery pack to your nearest Ryobi Authorized Service Center for checking or replacing.

- When your battery pack becomes fully charged, the red light will turn **OFF** and the green light will turn **ON**.
- After normal usage, 1 hour of charging time is required to be fully charged. A minimum charge time of 1-1/2 hours is required to recharge a completely discharged tool.

- The battery pack will become slightly warm to the touch while charging. This is normal and does not indicate a problem.
- **DO NOT** place charger in an area of extreme heat or cold. It will work best at normal room temperature.
- When the batteries become fully charged, unplug your charger from power supply and remove the battery pack.

LED FUNCTION OF CHARGER

LED WILL BE LIGHTED TO INDICATE STATUS OF CHARGER AND BATTERY PACK:

- Red LED Lighted = Fast Charging Mode.
- Green LED Lighted = Fully Charged Or In Slow Charging Mode To Maintain Battery Pack Charge.
- Red LED Flashing = Hot or Deeply Discharged Battery Pack. Also Defective Battery Pack After 1 hour.
- Yellow LED Lighted and Red LED Flashing = Defective Battery Pack.

IMPORTANT INFORMATION FOR RECHARGING HOT BATTERIES USING CHARGER PART NUMBER 1400677

See Figure 3.

When using your saw continuously, the batteries in your battery pack will become hot. You should let a hot battery pack cool down for approximately 30 minutes before attempting to recharge. When the battery pack becomes discharged and is hot, this will cause the red light on your battery charger to flash. When battery pack cools down, red light will glow continuously indicating fast charging mode, 1 hour charge time. Once the battery pack cools down, it will recharge battery pack in fast charging mode as normal.

NOTE: This situation only occurs when continuous use of your saw causes the batteries to become hot. **It does not occur under normal circumstances.** Refer to "**CHARGING BATTERY PACK WITH CHARGER PART NUMBER 1400677**" for normal recharging of batteries. If the charger does not charge your battery pack under normal circumstances, return **both** the battery pack and charger to your nearest Ryobi Authorized Service Center for electrical check.

OPERATION

WARNING:

Always remove battery pack from your saw when you are assembling parts, making adjustments, assembling or removing blades, cleaning, or when not in use. Removing battery pack will prevent accidental starting that could cause serious personal injury.

TO REMOVE BATTERY PACK

- Locate latches on end of battery pack and depress to release battery pack from your saw. *See Figure 4.*
- Remove battery pack from your saw.

WARNING:

Failure to remove battery pack from saw could result in accidental starting causing possible serious personal injury.

TO INSTALL BATTERY PACK

See Figure 4.

- Place battery pack in your saw. Align raised rib inside saw with groove on battery pack.
- Make sure the latches on each side of your battery pack snap in place and battery pack is secured in saw before beginning operation.

CAUTION:

When placing battery pack in your saw, be sure raised rib inside saw aligns with groove on battery pack and latches snap in place properly. Improper assembly of battery pack can cause damage to internal components.

WARNING:

A 5-1/2 in. (140 mm) blade is the maximum blade capacity of your saw. Never use a blade that is too thick to allow outer blade washer to engage with the flats on the spindle. Larger blades will come in contact with the blade guard, while thicker blades will prevent blade screw from securing blade on spindle. Either of these situations could result in a serious accident.

TO ASSEMBLE OR REMOVE BLADE

TO ASSEMBLE BLADE:

- Remove battery pack from saw.

WARNING:

Failure to remove battery pack from saw could result in accidental starting causing possible serious personal injury.

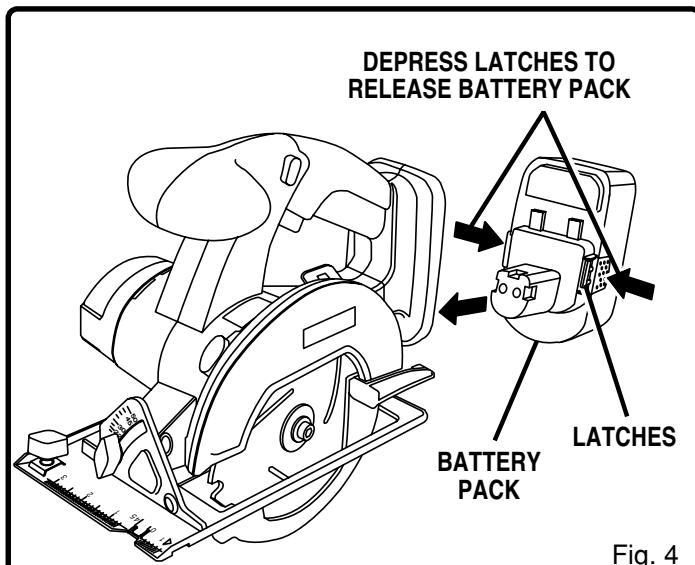

Fig. 4

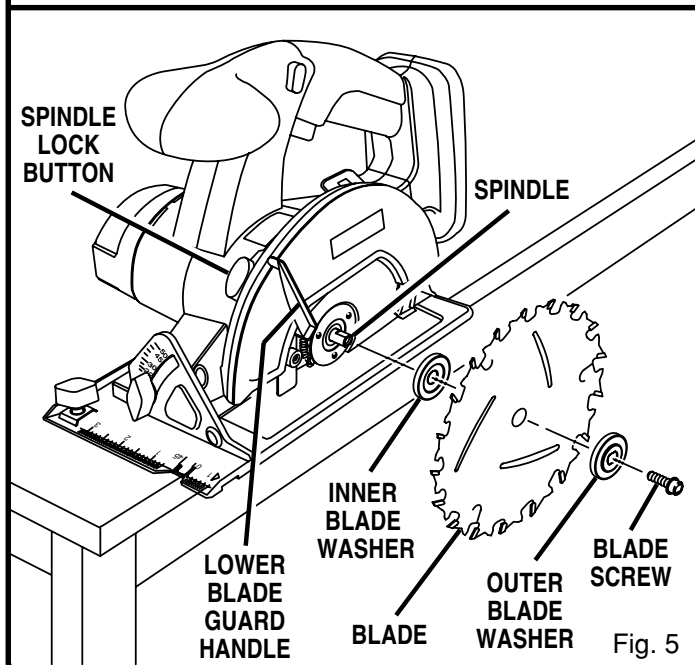

Fig. 5

- Locate latches on end of battery pack and depress to release battery pack from your saw. *See Figure 4.*
- Remove blade wrench (5 mm hex key) from storage area. *See Figure 1.*
- Depress spindle lock button and remove blade screw and outer blade washer. *See Figure 5.*
NOTE: Turn blade screw clockwise to remove.
- Wipe a drop of oil onto inner blade washer and outer blade washer where they contact blade.

WARNING:

If inner blade washer has been removed, replace it before placing blade on spindle. Failure to do so could cause an accident since blade will not tighten properly.

OPERATION

- Fit saw blade inside lower blade guard and onto spindle.
NOTE: The saw teeth point upward at the front of saw as shown in figure 5.

- Replace outer blade washer.

- Depress spindle lock button, then replace blade screw. Tighten blade screw securely.

NOTE: Turn blade screw counterclockwise to tighten.

- Return blade wrench to storage area.

REMEMBER: Never use a blade that is too thick to allow the outer blade washer to engage with the flats on the spindle.

TO REMOVE BLADE:

- Remove battery pack from saw.

WARNING:

Failure to remove battery pack from saw could result in accidental starting causing possible serious personal injury.

- Remove blade wrench from storage area. *See Figure 1.*
- Position your saw as shown in figure 6, depress spindle lock button, and remove blade screw.

NOTE: Turn blade screw clockwise to remove.

- Remove outer blade washer. *See Figure 5.*

NOTE: Blade can be removed at this point.

SAW BLADES

The best of saw blades will not cut efficiently if they are not kept clean, sharp, and properly set. Using a dull blade will place a heavy load on your saw and increase the danger of kickback. Keep extra blades on hand, so that sharp blades are always available.

Gum and wood pitch hardened on blades will slow your saw down. Use gum and pitch remover, hot water, or kerosene to remove these accumulations. **DO NOT USE GASOLINE.**

BLADE GUARD SYSTEM

The lower blade guard attached to your cordless circular saw is there for your protection and safety. It should never be altered for any reason. If it becomes damaged or begins to return slow or sluggish, do not operate your saw until the damage has been repaired or replaced. Always leave guard in operating position when using saw.

DANGER:

When sawing through workpiece, lower blade guard does not cover blade on the underside of workpiece. Since blade is exposed on underside of workpiece, keep hands and fingers away from cutting area. Any part of your body coming in contact with moving blade will result in serious injury. *See Figure 7.*

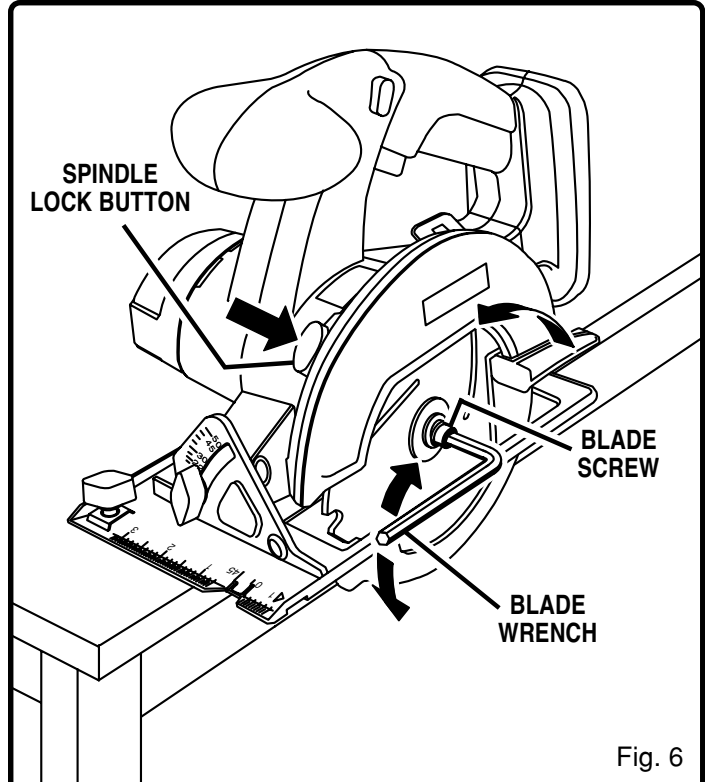

Fig. 6

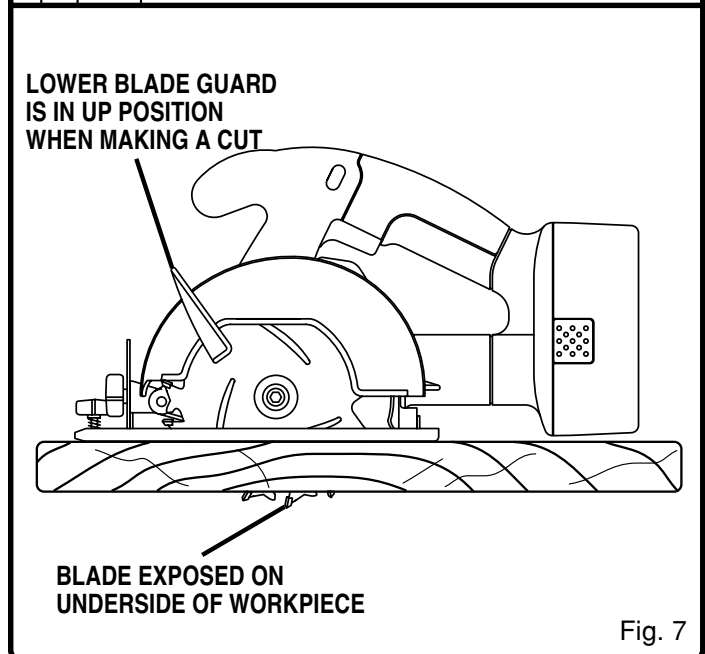

Fig. 7

Never use saw when guard is not operating correctly. Guard should be checked for correct operation before each use. If you drop your saw, check the lower blade guard and bumper for damage at all depth settings before reuse.

NOTE: The guard is operating correctly when it moves freely and readily returns to the closed position. If for any reason your lower blade guard does not close freely, take it to the nearest Ryobi authorized service center for service before using.

OPERATION

KICKBACK

See Figure 8.

The best guard against kickback is to avoid dangerous practices.

Kickback occurs when the blade stalls rapidly and the saw is driven back towards you. Blade stalling is caused by any action which pinches the blade in the wood.



DANGER:

Release switch immediately if blade binds or saw stalls. Kickback could cause you to lose control of your saw. Loss of control can lead to serious injury.

KICKBACK IS CAUSED BY:

- Incorrect blade depth setting. See Figure 8.
- Sawing into knots or nails in workpiece.
- Twisting blade while making a cut.
- Making a cut with a dull, gummed up, or improperly set blade.
- Incorrectly supporting workpiece. See Figure 9.
- Forcing a cut.
- Cutting warped or wet lumber.
- Tool misuse or incorrect operating procedures.

TO LESSEN THE CHANCE OF KICKBACK:

- Always keep the correct blade depth setting – the correct blade depth setting for all cuts should not exceed 1/4 in. below the material to be cut. See Figure 10. One blade tooth below the material to be cut works best for most efficient cutting action.
- Inspect the workpiece for knots or nails before beginning a cut. Never saw into a knot or nail.
- Make straight cuts. Always use a straight edge guide when rip cutting. This helps prevent twisting the blade in the cut.
- Always use clean, sharp and properly set blades. Never make cuts with dull blades.
- To avoid pinching the blade, support the workpiece properly before beginning a cut. The right and wrong ways to support large pieces of work are shown in figures 9 and 11.

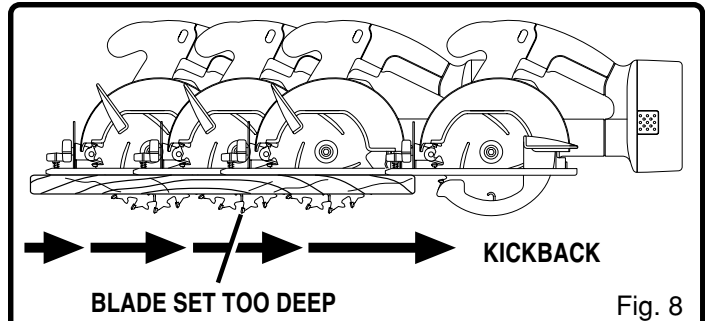

Fig. 8

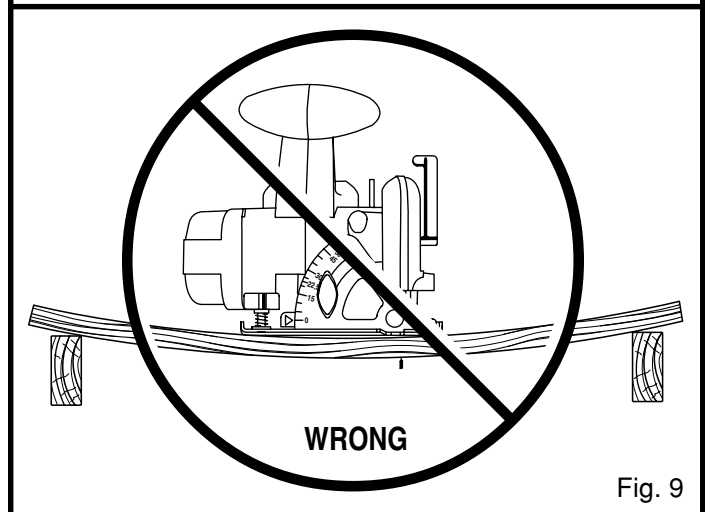

Fig. 9

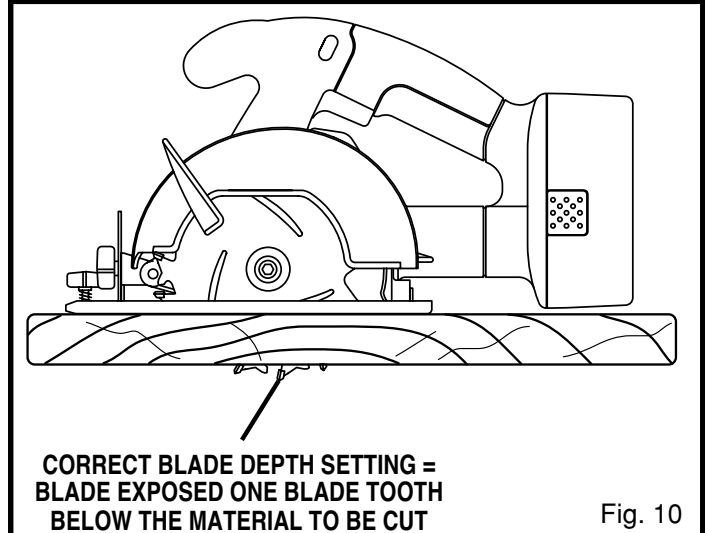

Fig. 10

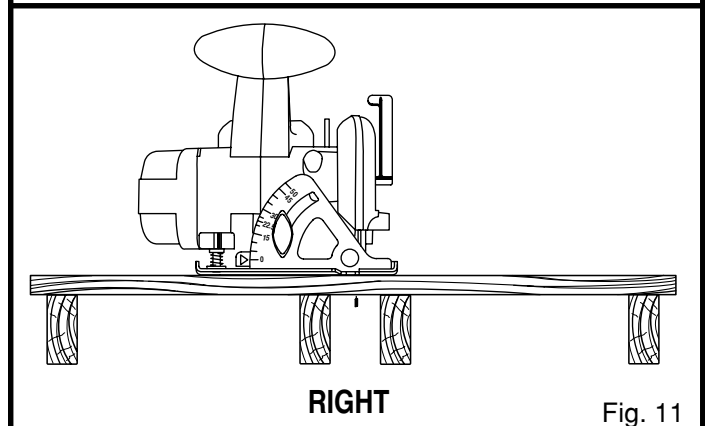

Fig. 11

OPERATION

- When making a cut use steady, even pressure. Never force cuts.
- Do not cut warped or wet lumber.
- Always hold your saw firmly with both hands and keep your body in a balanced position so as to resist the forces of kickback should it occur.

When using your saw, always stay alert and exercise control. Do not remove your saw from workpiece while the blade is moving.

DEPTH OF CUT ADJUSTMENT

Always keep correct blade depth setting. The correct blade depth setting for all cuts should not exceed 1/4 inch (6.4 mm) below the material to be cut. More blade depth will increase the chance of kickback and cause the cut to be rough. One blade tooth below the material to be cut works best for most efficient cutting action.

TO ADJUST BLADE DEPTH

- Remove battery pack from saw.

WARNING:

Failure to remove battery pack from saw could result in accidental starting causing possible serious personal injury.

- Loosen depth adjustment knob. *See Figure 12.*
- Hold base flat against the workpiece and raise or lower saw until the required depth is reached.
- Tighten depth adjustment knob securely.

STARTING A CUT

Know the right way to use your saw.

See Figure 13.

Never use your saw as shown in figure 14.

Never place your hand on the workpiece behind your saw while making a cut.

WARNING:

To make sawing easier and safer, always maintain proper control of your saw. Loss of control of your saw could cause an accident resulting in possible serious injury.

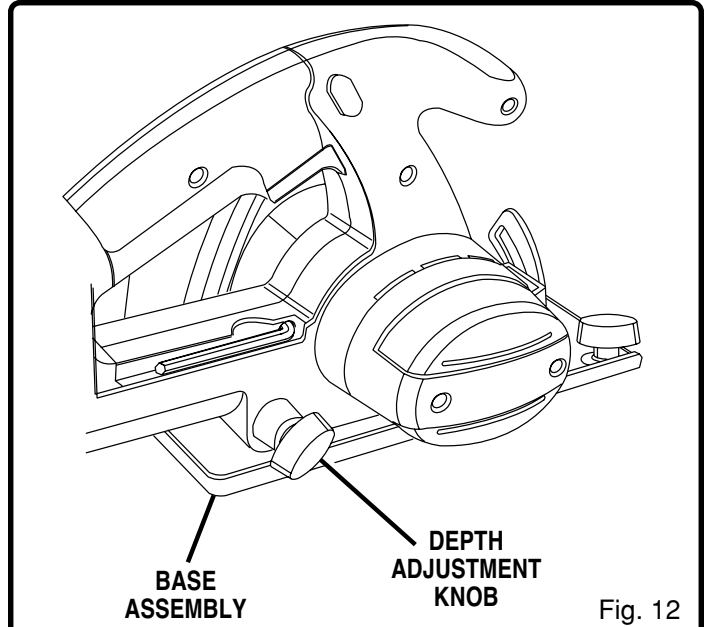

Fig. 12

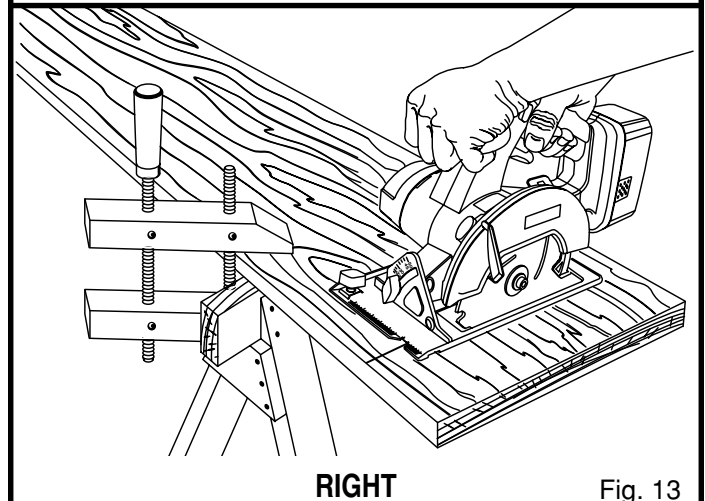

Fig. 13

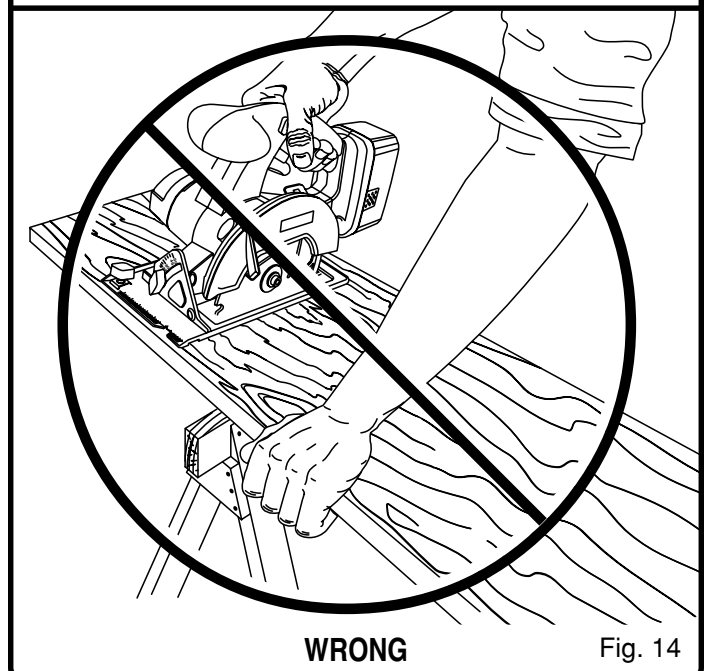

Fig. 14

OPERATION

TO HELP MAINTAIN CONTROL:

- Always support your workpiece near the cut.
- Support your workpiece so the cut will be on your left.
- Clamp your workpiece so it will not move during the cut.

Place your workpiece with its good side down.

NOTE: The good side is the side on which appearance is important.

Before beginning a cut, draw a guideline along the desired line of cut. Then place front edge of base on that part of your workpiece that is solidly supported. See Figure 13.

Never place your saw on that part of the workpiece that will fall off when the cut is made. See Figure 15.

Hold your saw firmly with both hands.

See Figure 16.

Depress the lock-off button and squeeze the switch trigger to start your saw. **Always** let the blade reach full speed, then guide your saw into the workpiece.

WARNING:

The blade coming in contact with the workpiece before it reaches full speed could cause your saw to "kickback" towards you resulting in serious injury.

When making a cut use steady, even pressure. Forcing causes rough cuts, could shorten the life of your saw and could cause "kickback."

DANGER:

When sawing through work, the lower blade guard does not cover the blade, exposing it on the underside of work. Keep your hands and fingers away from cutting area. Any part of your body coming in contact with the moving blade will result in serious injury.

After you complete your cut release the trigger and allow the blade to come to a complete stop. **Do not remove your saw from workpiece while the blade is moving.**

CAUTION:

To make sawing easier and safer, always maintain proper control of your saw. Loss of control of your saw could cause an accident resulting in possible serious injury.

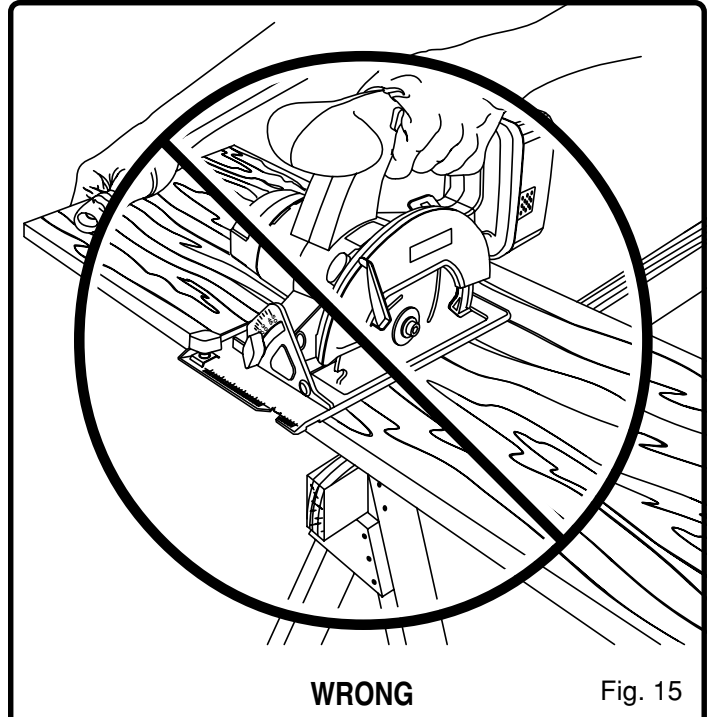

WRONG

Fig. 15

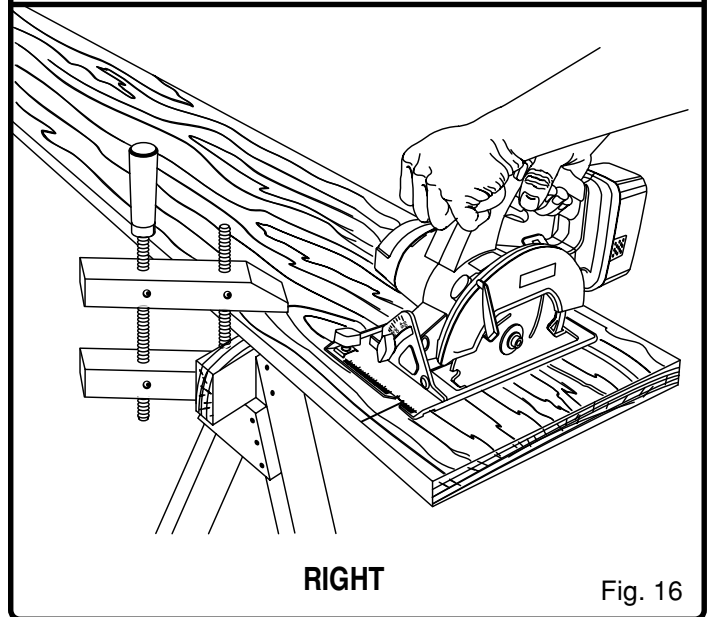

RIGHT

Fig. 16

OPERATION

TO CROSS CUT OR RIP CUT

When making a cross cut or rip cut, align your line of cut with the outer blade guide notch on the saw base as shown in figure 17.

Since blade thicknesses vary, always make a trial cut in scrap material along a guideline to determine how much, if any, the guideline must be offset to produce an accurate cut.

NOTE: The distance from the line of cut to the guideline is the amount you should offset the guideline.

WIDTH OF CUT SCALE

See Figure 18.

A width of cut scale has been provided on the base of your saw. When making straight cross cuts or rip cuts, the scale can be used to measure up to four inches to the right side of the blade. It can be used to measure up to one inch to the left side of the blade.

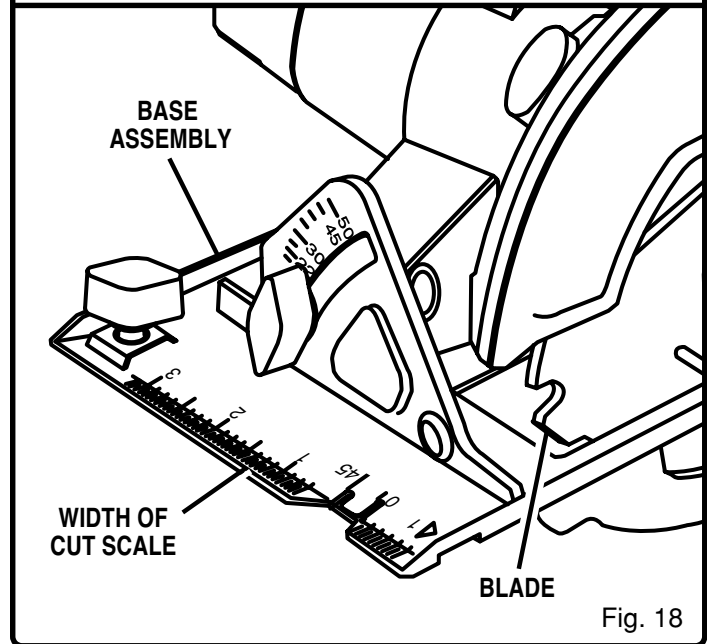
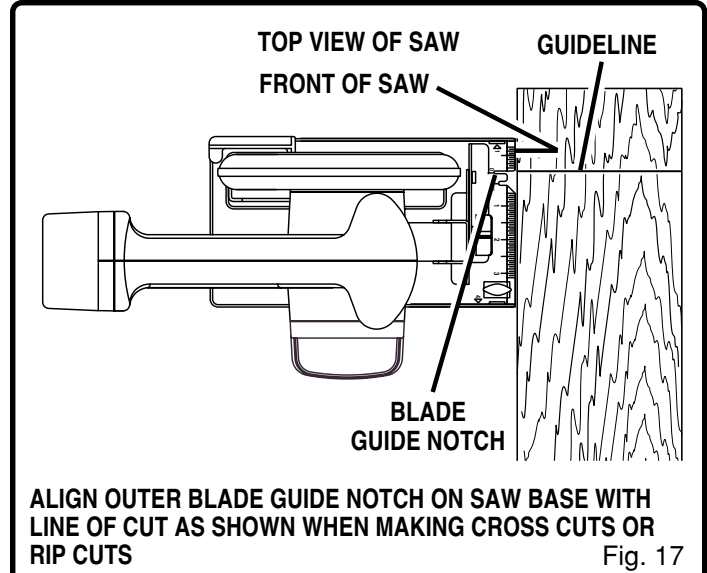

OPERATION

TO BEVEL CUT

The angle of cut of your saw may be adjusted to any desired setting between zero and 50°. **NOTE:** When making cuts at 50°, blade should be set at full depth of cut.

When making 45° bevel cuts, there is a notch in the saw base to help you line up the blade with the line of cut.

See Figure 19.

Align your line of cut with the inner blade guide notch on the saw base when making 45° bevel cuts.

Since blade thicknesses vary and different angles require different settings, always make a trial cut in scrap material along a guideline to determine how much you should offset the guideline on the board to be cut.

When making a bevel cut hold your saw firmly with both hands as shown in figure 20.

Rest the front edge of the base on the workpiece. Depress the lock-off button and squeeze the switch trigger to start your saw. **Always** let the blade reach full speed, then guide your saw into the workpiece.

WARNING:

The blade coming in contact with the workpiece before it reaches full speed could cause saw to "kickback" toward you resulting in serious injury.

After you complete your cut release the trigger and allow the blade to come to a complete stop. **After** the blade has stopped, lift your saw from the workpiece.

TO ADJUST BEVEL SETTING

- Remove battery pack from saw.

WARNING:

Failure to remove battery pack from saw could result in accidental starting causing possible serious personal injury.

- Loosen bevel adjustment knob. See Figure 19.
- Raise motor housing end of saw until you reach desired angle setting on bevel scale. See Figure 19.
- Tighten bevel adjustment knob securely.

WARNING:

Attempting bevel cut without knob securely tightened can result in serious injury.

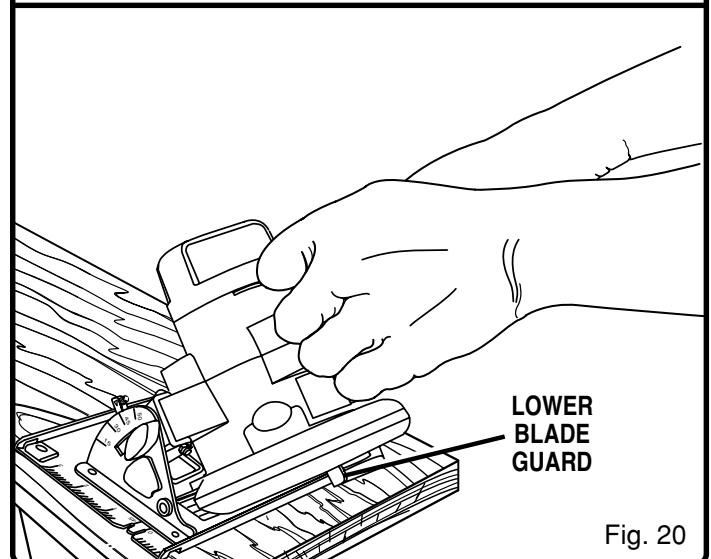
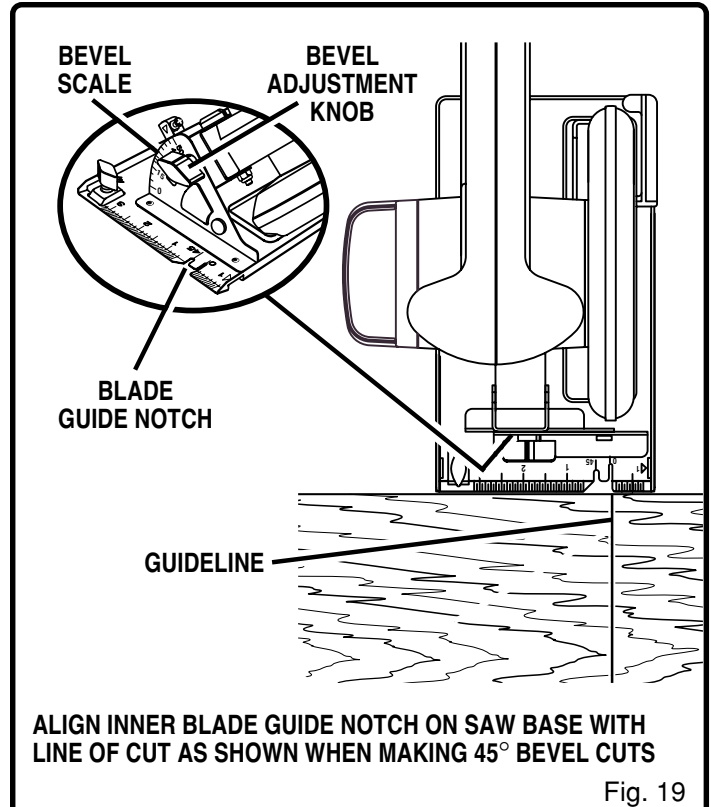

OPERATION

POSITIVE 0° BEVEL STOP

See Figure 21.

Your saw has a positive 0° bevel stop, that has been factory adjusted to assure 0° angle of your saw blade when making 90° cuts. However, misalignment can occur during shipping.

TO CHECK

- Remove battery pack from saw.

WARNING:

Failure to remove battery pack from saw could result in accidental starting causing possible serious personal injury.

- Place your saw in an upside down position on workbench. See Figure 21.
- Using a carpenter's square, check squareness of saw blade to the base of your saw.

TO ADJUST

- Remove battery pack from saw.

WARNING:

Failure to remove battery pack from saw could result in accidental starting causing possible serious personal injury.

- Loosen bevel adjustment knob.
- Loosen hex nut securing adjustment screw.
- Turn screw and adjust base until square with saw blade.
- Tighten hex nut and bevel adjustment knob securely.

WARNING:

Attempting to make cuts without bevel adjustment knob securely tightened can result in serious injury.

TO POCKET CUT

See Figure 22.

WARNING:

Always adjust bevel setting to zero before making a pocket cut. Attempting a pocket cut at any other setting can result in loss of control of your saw possibly causing serious injury.

Adjust the bevel setting to zero, set blade to correct blade depth setting, and swing the lower blade guard up using the lower blade guard handle.

Always raise the lower blade guard with the handle to avoid serious injury.

While holding lower blade guard by the handle, firmly rest the

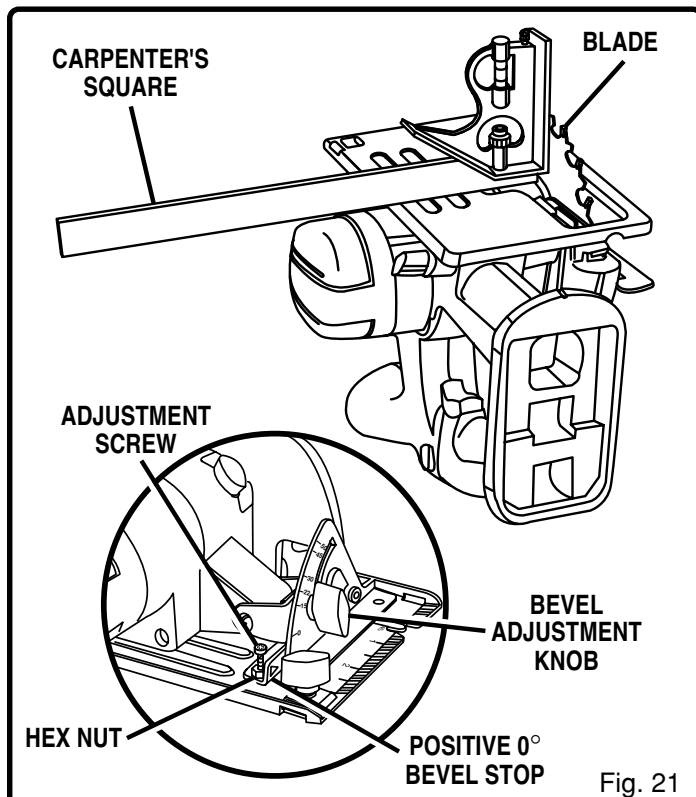

Fig. 21

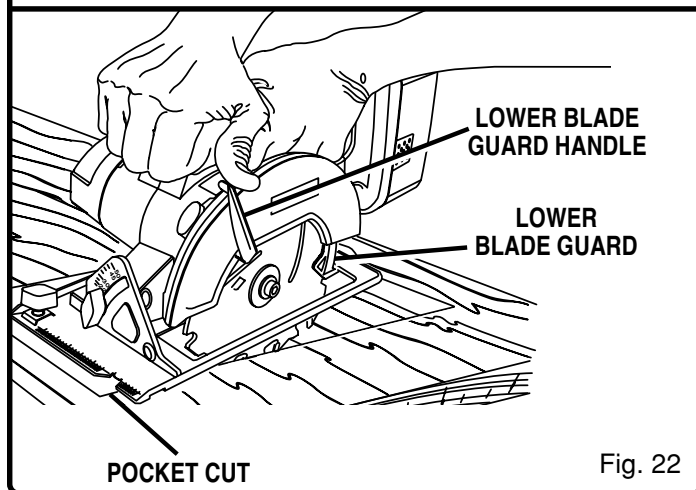

Fig. 22

front of the base flat against the workpiece with the rear of the handle raised so the blade does not touch the workpiece. See Figure 22.

Depress the lock-off button and squeeze the switch trigger to start your saw. **Always let the blade reach full speed then slowly lower blade into the workpiece until base is flat against workpiece.**

After you complete your cut release the trigger and allow the blade to come to a complete stop. After the blade has stopped, remove it from the workpiece. Corners may then be cleared out with a hand saw or sabre saw.

WARNING:

Never tie the lower blade guard in a raised position. Leaving the blade exposed could lead to serious injury.

OPERATION

TO RIP CUT

OPTIONAL RIP GUIDE (EDGE GUIDE)

See Figure 23.

Use a guide when making long or wide rip cuts with your saw. An optional rip guide with a five inch scale is available or you can make an efficient rip guide by clamping a straight edge to your workpiece. Secure the workpiece. Using C-clamps, firmly clamp a straight edge to the workpiece and guide the saw along the straight edge to achieve a straight rip cut. Do not bind the blade in the cut. If using the optional rip guide, see the following instructions and figure 24.

TO ASSEMBLE OPTIONAL RIP GUIDE

See Figure 24.

- Remove battery pack from saw.

WARNING:

Failure to remove battery pack from saw could result in accidental starting causing possible serious personal injury.

- Place rip guide through holes in saw base as shown in figure 24.
- Adjust rip guide to the width needed.
- Tighten rip guide screw (wing screw) securely.

When using a rip guide, position the face of the rip guide firmly against the edge of workpiece. This makes for a true cut without pinching the blade. The guiding edge of workpiece must be straight for your cut to be straight. Use caution to prevent the blade from binding in the cut.

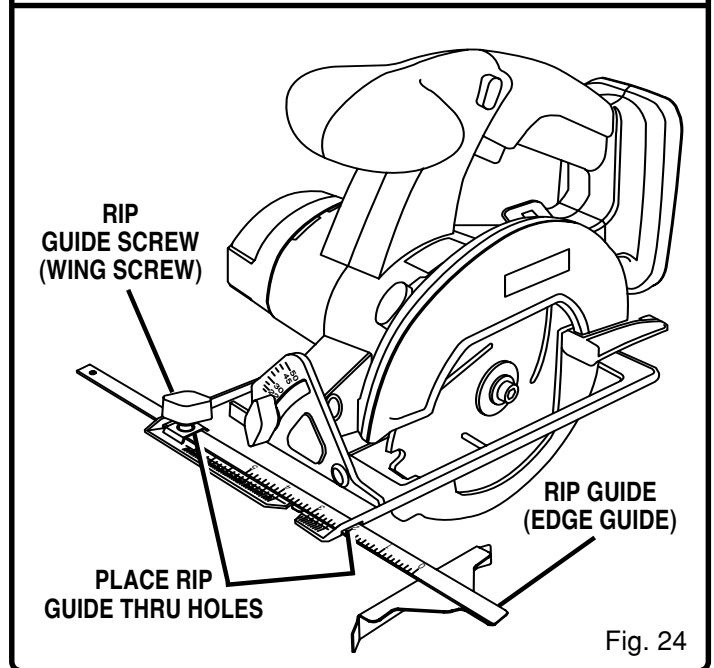
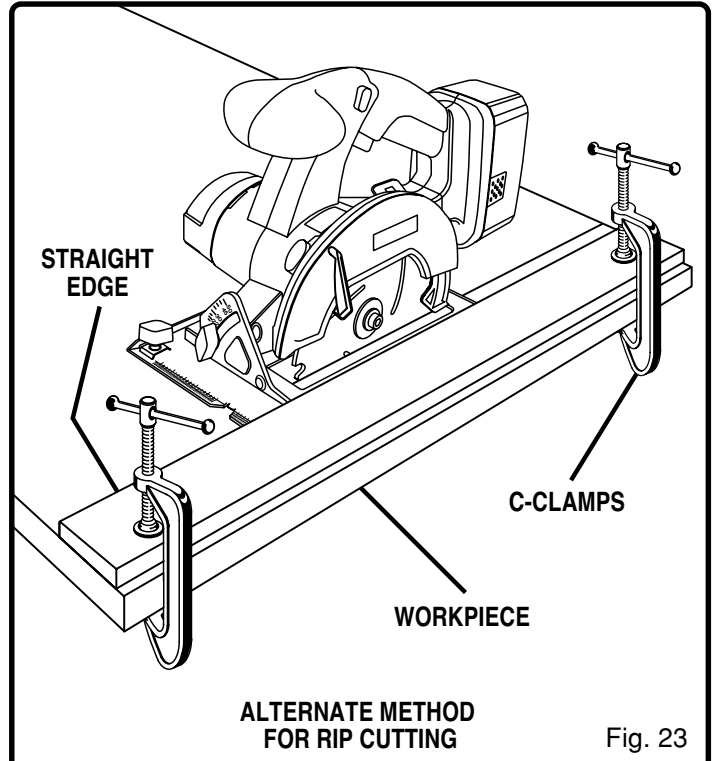

MAINTENANCE



WARNING:

When servicing, use only identical replacement parts. Use of any other part may create a hazard or cause product damage.



WARNING:

Do not at any time let brake fluids, gasoline, petroleum-based products, penetrating oils, etc. come in contact with plastic parts. They contain chemicals that can damage, weaken or destroy plastic.

DO NOT abuse power tools. Abusive practices can damage tool as well as workpiece.



WARNING:

Do not attempt to modify this tool or create accessories not recommended for use with this tool. Any such alteration or modification is misuse and could result in a hazardous condition leading to possible serious personal injury.

BATTERIES

Your saw's battery pack is equipped with nickel-cadmium rechargeable batteries. Length of service from each charging will depend on the type of work you are doing.

The batteries in this tool have been designed to provide maximum trouble free life. However, like all batteries, they will eventually wear out. **DO NOT** disassemble battery pack and attempt to replace the batteries. Handling of these batteries, especially when wearing rings and jewelry, could result in a serious burn.

To obtain the longest possible battery life, we suggest the following:

- Store and charge your batteries in a cool area. Temperatures above normal room temperature will shorten battery life.
- Never store batteries in a discharged condition. Recharge them immediately after they are discharged.
- All batteries gradually lose their charge. The higher the temperature the quicker they lose their charge. If you store your tool for long periods of time without using it, recharge the batteries every month or two. This practice will prolong battery.

BATTERY PACK REMOVAL AND PREPARATION FOR RECYCLING



To preserve natural resources, please recycle or dispose of batteries properly.

This product contains nickel-cadmium batteries. Local, state or federal laws may prohibit disposal of nickel-cadmium batteries in ordinary trash.

Consult your local waste authority for information regarding available recycling and/or disposal options.



WARNING:

Upon removal, cover the battery pack's terminals with heavy duty adhesive tape. Do not attempt to destroy or disassemble battery pack or remove any of its components. Nickel-cadmium batteries must be recycled or disposed of properly. Also, never touch both terminals with metal objects and/or body parts as short circuit may result. Keep away from children. Failure to comply with these warnings could result in fire and/or serious injury.

RYOBI CORDLESS CIRCULAR SAW - MODEL NUMBER R10630

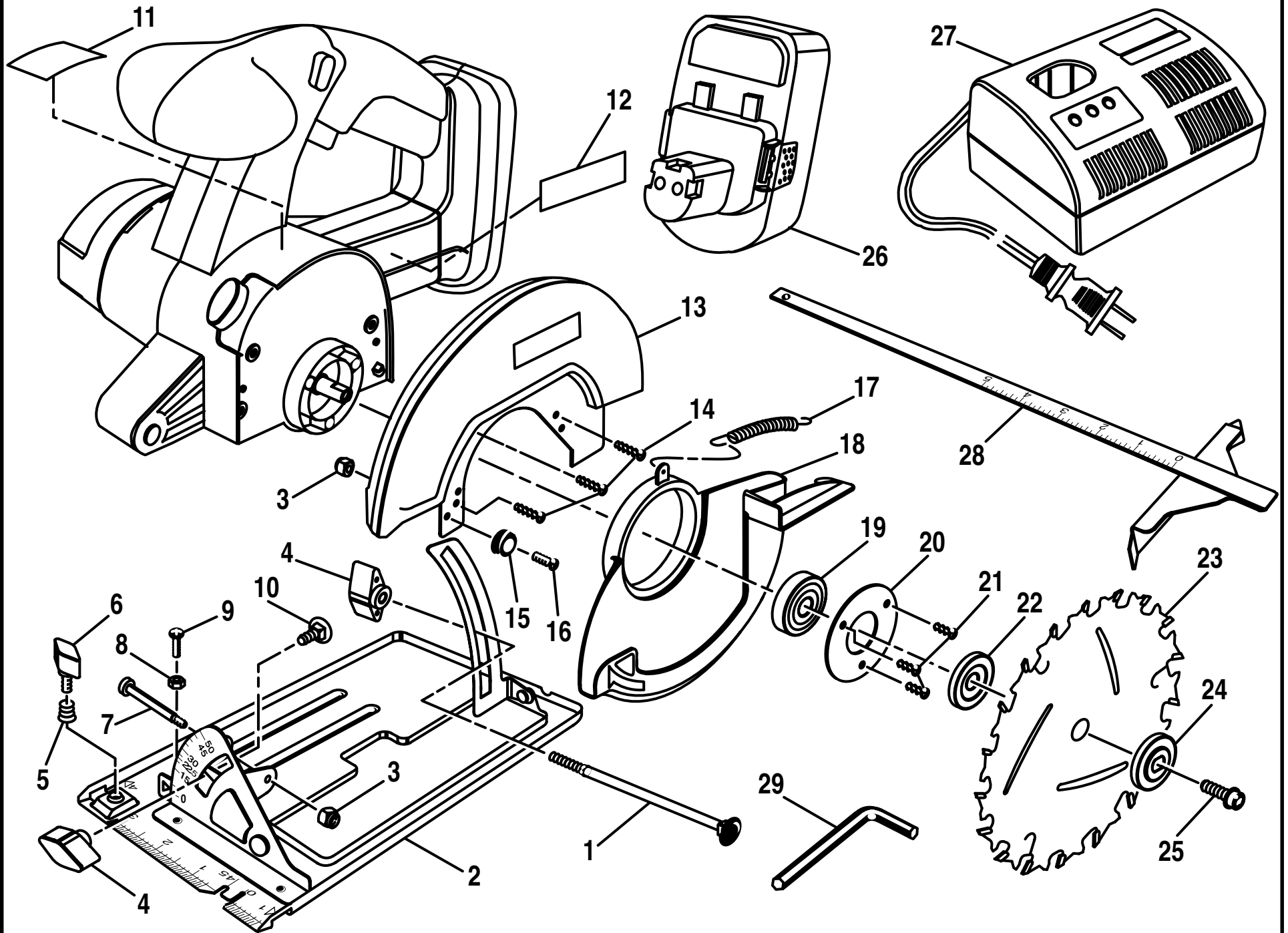

RYOBI CORDLESS CIRCULAR SAW - MODEL NUMBER R10630

The model number will be found on a plate attached to the motor housing. Always mention the model number in all correspondence regarding your **CORDLESS CIRCULAR SAW** or when ordering repair parts.

SEE BACK PAGE FOR PARTS ORDERING INSTRUCTIONS

PARTS LIST

| Key No. | Part Number | Description | Quan. | Key No. | Part Number | Description | Quan. |
|---------|-------------|-----------------------------------|-------|---------|-------------|-----------------------------------|-------|
| 1 | 975546-000 | Carriage Bolt (M6 x 102 mm) | 1 | 16 | 975541-000 | Bumper Screw | 1 |
| 2 | 975547-000 | Base Assembly | 1 | 17 | 975540-000 | Spring | 1 |
| 3 | 975544-000 | Lock Nut | 2 | 18 | 975539-000 | Lower Blade Guard | 1 |
| 4 | 975548-000 | Knob | 2 | 19 | 975538-000 | Ball Bearing (NTN #6200LB) | 1 |
| 5 | 975552-000 | Spring | 1 | 20 | 975537-000 | Bearing Retainer | 1 |
| 6 | 975551-000 | Rip Guide Screw | 1 | 21 | 975536-000 | Bearing Retainer Screw | 3 |
| 7 | 975549-000 | Base Screw | 1 | 22 | 975534-000 | Inner Blade Washer | 1 |
| 8 | 975559-000 | Hex Nut | 1 | 23 | 975419-001 | Saw Blade | 1 |
| 9 | 975558-000 | Screw | 1 | 24 | 975533-000 | Outer Blade Washer | 1 |
| 10 | 975550-000 | Carriage Bolt (M6 x 13 mm) | 1 | 25 | 975532-000 | Blade Screw | 1 |
| 11 | 980057-000 | Data Plate | 1 | 26 | 980011-000 | Battery Pack | 1 |
| 12 | 975557-000 | Warning Label | 1 | 27 | 977405-000 | Charger | 1 |
| 13 | 975545-000 | Upper Blade Guard | 1 | 28 | 975554-000 | Optional Rip Guide | 1 |
| 14 | 975543-000 | Upper Blade Guard Screw | 3 | 29 | 975553-000 | Blade Wrench (5 mm Hex Key) | 1 |
| 15 | 975542-000 | Bumper | 1 | 30 | 980058-000 | Carrying Case - Not Shown | 1 |
| | | | | | 972000-573 | Operator's Manual | |

RYOBI OPERATOR'S MANUAL **5-1/2 in. CORDLESS CIRCULAR SAW** **MODEL NO. R10630**

- **SERVICE**

Now that you have purchased your tool, should a need ever exist for repair parts or service, simply contact your nearest Ryobi Authorized Service Center. Be sure to provide all pertinent facts when you call or visit. Please refer to the Service Center insert or call 1-800-525-2579 in the United States or 1-800-265-6778 in Canada for your nearest Ryobi Authorized Service Center. You can also check our web site at www.ryobi.com for a complete list of Authorized Service Centers.

- **MODEL NO. AND SERIAL NO.**

The model number of this tool will be found on a plate attached to the motor housing. Please record the model number and serial number in the space provided below.

- **HOW TO ORDER REPAIR PARTS**

WHEN ORDERING REPAIR PARTS,
ALWAYS GIVE THE FOLLOWING INFORMATION:

- MODEL NUMBER **R10630**
- SERIAL NUMBER _____

RYOBI TECHNOLOGIES INC.

1428 Pearman Dairy Road Anderson, SC 29622
Post Office Box 1207 Anderson, SC 29622-1207
Phone 1-800-525-2579

RYOBI TECHNOLOGIES INC.

Post Office Box 910
Cambridge, Ontario N1R 6K2
Phone 1-800-265-6778