



OPERATOR'S MANUAL

5-1/2 in., 18 VOLT

LASER CIRCULAR SAW

P500

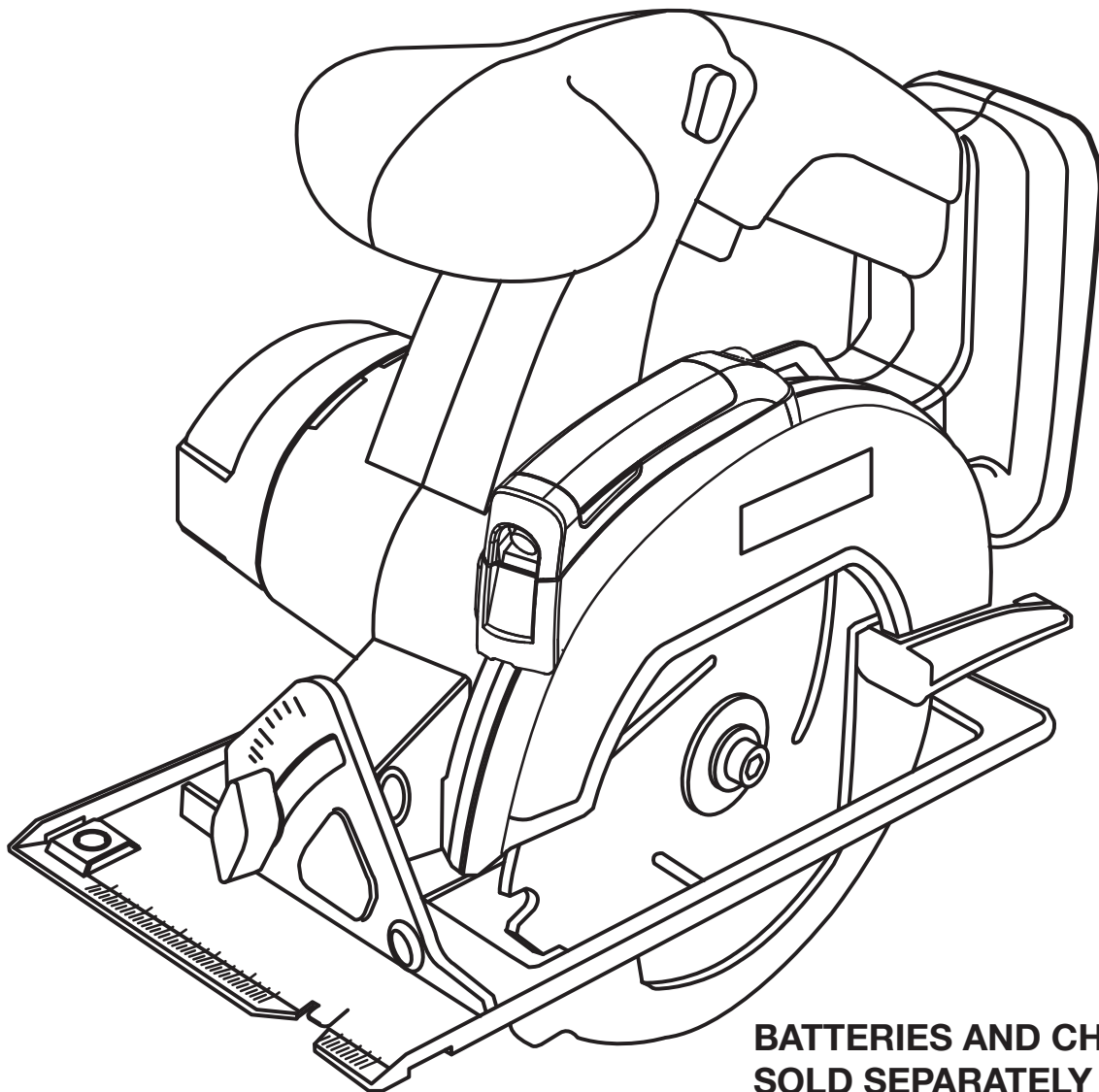

**BATTERIES AND CHARGERS
SOLD SEPARATELY**

Your laser circular saw has been engineered and manufactured to Ryobi's high standard for dependability, ease of operation, and operator safety. When properly cared for, it will give you years of rugged, trouble-free performance.

⚠ WARNING: To reduce the risk of injury, the user must read and understand the operator's manual before using this product.

Thank you for buying a Ryobi product.

SAVE THIS MANUAL FOR FUTURE REFERENCE

TABLE OF CONTENTS

■ Introduction	2
■ General Safety Rules	3
■ Specific Safety Rules	4-5
■ Safety Rules for Charger	6
■ Symbols	7-8
■ Features	9-10
■ Assembly	10-11
■ Operation	12-20
■ Adjustments	21
■ Maintenance	22-23
■ Accessories	23
■ Parts Ordering / Service	24

INTRODUCTION

This tool has many features for making its use more pleasant and enjoyable. Safety, performance, and dependability have been given top priority in the design of this product making it easy to maintain and operate.

GENERAL SAFETY RULES

WARNING!

READ AND UNDERSTAND ALL INSTRUCTIONS. Failure to follow all instructions listed below, may result in electric shock, fire and/or serious personal injury.

SAVE THESE INSTRUCTIONS

WORK AREA

- **Keep your work area clean and well lit.** Cluttered benches and dark areas invite accidents.
- **Do not operate power tools in explosive atmospheres, such as in the presence of flammable liquids, gases, or dust.** Power tools create sparks which may ignite the dust or fumes.
- **Keep bystanders, children, and visitors away while operating a power tool.** Distractions can cause you to lose control.

ELECTRICAL SAFETY

- **A battery operated tool with integral batteries or a separate battery pack must be recharged only with the specified charger for the battery.** A charger that may be suitable for one type of battery may create a risk of fire when used with another battery.
- **Use battery operated tool only with specifically designated battery pack.** Use of any other batteries may create a risk of fire.
- **Use battery only with charger listed.**

MODEL	BATTERY PACK (P100)	CHARGER (P110)
P500	130255004 130224028	1423701,140237023 or 140237021

- **Do not abuse the cord. Never use the cord to carry the charger. Keep cord away from heat, oil, sharp edges, or moving parts. Replace damaged cords immediately.** Damaged cords may create a fire.

PERSONAL SAFETY

- **Stay alert, watch what you are doing and use common sense when operating a power tool. Do not use tool while tired or under the influence of drugs, alcohol, or medication.** A moment of inattention while operating power tools may result in serious personal injury.
- **Dress properly. Do not wear loose clothing or jewelry. Contain long hair. Keep your hair, clothing, and gloves away from moving parts.** Loose clothes, jewelry, or long hair can be caught in moving parts.
- **Avoid accidental starting. Be sure switch is in the locked or off position before inserting battery pack.** Carrying tools with your finger on the switch or inserting the battery pack into a tool with the switch on invites accidents.
- **Remove adjusting keys or wrenches before turning the tool on.** A wrench or a key that is left attached to a rotating part of the tool may result in personal injury.

- **Do not overreach. Keep proper footing and balance at all times.** Proper footing and balance enable better control of the tool in unexpected situations.
- **Use safety equipment. Always wear eye protection.** Dust mask, non-skid safety shoes, hard hat, or hearing protection must be used for appropriate conditions.
- **Do not wear loose clothing or jewelry. Contain long hair.** Loose clothes, jewelry, or long hair can be drawn into air vents.
- **Do not use on a ladder or unstable support.** Stable footing on a solid surface enables better control of the tool in unexpected situations.

TOOL USE AND CARE

- **Use clamps or other practical way to secure and support the workpiece to a stable platform.** Holding the work by hand or against your body is unstable and may lead to loss of control.
- **Do not force tool. Use the correct tool for your application.** The correct tool will do the job better and safer at the rate for which it is designed.
- **Do not use tool if switch does not turn it on or off.** A tool that cannot be controlled with the switch is dangerous and must be repaired.
- **Disconnect battery pack from tool or place the switch in the locked or off position before making any adjustments, changing accessories, or storing the tool.** Such preventive safety measures reduce the risk of starting the tool accidentally.
- **Store idle tools out of reach of children and other untrained persons.** Tools are dangerous in the hands of untrained users.
- **When battery pack is not in use, keep it away from other metal objects like: paper clips, coins, keys, nails, screws, or other small metal objects that can make a connection from one terminal to another.** Shorting the battery terminals together may cause sparks, burns, or a fire.
- **Maintain tools with care. Keep cutting tools sharp and clean.** Properly maintained tools with sharp cutting edges are less likely to bind and are easier to control.
- **Check for misalignment or binding of moving parts, breakage of parts, and any other condition that may affect the tool's operation. If damaged, have the tool serviced before using.** Many accidents are caused by poorly maintained tools.
- **Use only accessories that are recommended by the manufacturer for your model.** Accessories that may be suitable for one tool may create a risk of injury when used on another tool.
- **Keep the tool and its handle dry, clean and free from oil and grease.** Always use a clean cloth when cleaning. Never use brake fluids, gasoline, petroleum-based products, or any strong solvents to clean your tool. Following this rule will reduce the risk of loss of control and deterioration of the enclosure plastic.

GENERAL SAFETY RULES

SERVICE

- **Tool service must be performed only by qualified repair personnel.** Service or maintenance performed by unqualified personnel may result in a risk of injury.
- **When servicing a tool, use only identical replacement parts. Follow instructions in the Maintenance section of this manual.** Use of unauthorized parts or failure to follow Maintenance Instructions may create a risk of shock or injury.

SPECIFIC SAFETY RULES

- **DANGER! Keep hands away from cutting area and blade. Keep your second hand on the auxiliary handle or motor housing.** If both hands are holding the saw, they cannot be cut by the blade.
 - **Keep your body positioned to either side of the saw blade, but not in line with the saw blade. KICKBACK** could cause the saw to jump backwards. (See “Causes And Operator Prevention Of Kickback” later.)
 - **Do not reach underneath the work.** The guard cannot protect you from the blade below the work.
 - **Check lower guard for proper closing before each use. Do not operate saw if lower guard does not move freely and close instantly. Never clamp or tie the lower guard into the open position.** If saw is accidentally dropped, lower guard may be bent. Raise the lower guard with the retracting handle. Make sure it moves freely and does not touch the blade or any other part, in all angles and depths of cut.
 - **Check the operation and condition of the lower guard spring. If the guard and the spring are not operating properly, they must be serviced before use.** Lower guard may operate sluggishly due to damaged parts, gummy deposits, or a buildup of debris.
 - **Lower guard should be retracted manually only for special cuts, such as "Pocket Cuts" and "Compound Cuts." Raise lower guard by retracting handle. As soon as blade enters the material, lower guard must be released.** For all other sawing, the lower guard should operate automatically.
 - **Always observe that the lower guard is covering the blade before placing saw down on bench or floor.** An unprotected, coasting blade will cause the saw to walk backwards, cutting whatever is in its path. Be aware of the time it takes for the blade to stop after switch is released.
 - **NEVER hold piece being cut in your hands or across your leg.** It is important to support the work properly to minimize body exposure, blade binding, or loss of control.
 - **Hold tool by insulated gripping surfaces when performing an operation where the cutting tool may contact hidden wiring or its own cord.** Contact with a “live” wire will make exposed metal parts of the tool “live” and shock the operator.
 - **When ripping, always use a rip fence or straight edge guide.** This improves the accuracy of the cut and reduces the chance for blade binding.
 - **Always use blades with correct size and shape (diamond vs. round) arbor holes.** Blades that do not match the mounting hardware of the saw will run eccentrically, causing loss of control.
 - **Never use damaged or incorrect blade washers or bolts.** The blade washers and bolts were specially designed for the saw for optimum performance and safety of operation.
- Causes and Operator Prevention of Kickback:**
Kickback is a sudden reaction to a pinched, bound, or misaligned saw blade, causing an uncontrolled saw to lift up and out of the workpiece toward the operator.
When the blade is pinched or bound tightly by the kerf closing down, the blade stalls and the motor reaction drives the unit rapidly back toward the operator.
If the blade becomes twisted or misaligned in the cut, the teeth at the back edge of the blade can dig into the top surface of the wood causing the blade to climb out of the kerf and jump back toward the operator.
Kickback is the result of tool misuse and/or incorrect operating procedures or conditions and can be avoided by taking proper precautions, as given below:
- **Maintain a firm grip with both hands on the saw and position your body and arm to allow you to resist KICKBACK forces.** KICKBACK forces can be controlled by the operator, if proper precautions are taken.
 - **When blade is binding, or when interrupting a cut for any reason, release the trigger and hold the saw motionless in the material until the blade comes to a complete stop. Never attempt to remove the saw from the work or pull the saw backward while the blade is in motion, or KICKBACK may occur.** Investigate and take corrective actions to eliminate the cause of blade binding.
 - **When restarting a saw in the workpiece, center the saw blade in the kerf and check that saw teeth are not engaged into the material.** If saw blade is binding, it may walk up or KICKBACK from the workpiece as the saw is restarted.

SPECIFIC SAFETY RULES

- **Support large panels to minimize the risk of blade pinching and KICKBACK.** Large panels tend to sag under their own weight. Supports must be placed under the panel on both sides, near the line of cut and near the edge of the panel.
- **Do not use dull or damaged blade.** Unsharpened or improperly set blades produce narrow kerf which causes excessive friction, blade binding and KICKBACK.
- **Blade depth and bevel adjusting locking levers must be tight and secure before making cut.** If blade adjustment shifts while cutting, it may cause binding and KICKBACK.
- **Use extra caution when making a “Pocket Cut” into existing walls or other blind areas.** The protruding blade may cut objects that can cause KICKBACK.
- **Know your power tool. Read operator’s manual carefully. Learn its applications and limitations, as well as the specific potential hazards related to this tool.** Following this rule will reduce the risk of electric shock, fire, or serious injury.
- **Always wear safety glasses. Everyday eyeglasses have only impact-resistant lenses; they are NOT safety glasses.** Following this rule will reduce the risk of serious personal injury.
- **Protect your lungs. Wear a face or dust mask if the operation is dusty.** Following this rule will reduce the risk of serious personal injury.
- **Protect your hearing. Wear hearing protection during extended periods of operation.** Following this rule will reduce the risk of serious personal injury.
- **Inspect tool cords periodically and, if damaged, have repaired at your nearest authorized service center. Constantly stay aware of cord location.** Following this rule will reduce the risk of electric shock or fire.
- **Check damaged parts. Before further use of the tool, a guard or other part that is damaged should be carefully checked to determine that it will operate properly and perform its intended function. Check for alignment of moving parts, binding of moving parts, breakage of parts, mounting, and any other conditions that may affect its operation. A guard or other part that is damaged should be properly repaired or replaced by an authorized service center.** Following this rule will reduce the risk of shock, fire, or serious injury.
- **Make sure your extension cord is in good condition. When using an extension cord, be sure to use one heavy enough to carry the current your product will draw. A wire gage size (A.W.G.) of at least 12 is recommended for an extension cord 50 feet or less in length. A cord exceeding 100 feet is not recommended. If in doubt, use the next heavier gage. The smaller the gage number, the heavier the cord. An undersized cord will cause a drop in line voltage resulting in loss of power and overheating.**
- **Inspect for and remove all nails from lumber before using this tool.** Following this rule will reduce the risk of serious personal injury.

Laser Guide Warnings:

The laser guide radiation used in the Ryobi circular saw is Class II with maximum <math><1\text{mW}</math> and 650nm wavelengths. These lasers do not normally present an optical hazard although staring at the beam may cause flash blindness.

- **Avoid** direct eye exposure when using the laser guide.
- The laser shall be used and maintained in accordance with the manufacturer’s instructions.
- Never aim the beam at a person or object other than the workpiece.
- Always ensure the laser beam is aimed at a sturdy workpiece without reflective surfaces. Shiny reflective sheet metal or similar shiny materials are not suitable for laser use.
- All repairs should be made by an authorized service representative or the laser manufacturer.
- **Save these instructions.** Refer to them frequently and use them to instruct others who may use this tool. If you loan someone this tool, loan them these instructions also.

SAFETY RULES FOR CHARGER

WARNING!

READ AND UNDERSTAND ALL INSTRUCTIONS.

Failure to follow all instructions listed below, may result in electric shock, fire and/or serious personal injury.

- **Before using battery charger**, read all instructions and cautionary markings in this manual, on battery charger, battery, and product using battery to prevent misuse of the products and possible injury or damage.

CAUTION:

To reduce the risk of electric shock or damage to the charger and battery, charge only nickel-cadmium rechargeable batteries as specifically designated on your charger. Other types of batteries may burst, causing personal injury or damage.

- **Do not use charger outdoors or expose to wet or damp conditions.** Water entering charger will increase the risk of electric shock.
- **Use of an attachment not recommended or sold by the battery charger manufacturer may result in a risk of fire, electric shock, or injury to persons.** Following this rule will reduce the risk of electric shock, fire, or serious personal injury.
- **Do not abuse cord or charger.** Never use the cord to carry the charger. Do not pull the charger cord rather than the plug when disconnecting from receptacle. Damage to the cord or charger could occur and create an electric shock hazard. Replace damaged cords immediately.
- **Make sure cord is located so that it will not be stepped on, tripped over, come in contact with sharp edges or moving parts or otherwise subjected to damage or stress.** This will reduce the risk of accidental falls, which could cause injury, and damage to the cord, which could result in electric shock.
- **Keep cord and charger from heat to prevent damage to housing or internal parts.**
- **Do not let gasoline, oils, petroleum-based products, etc. come in contact with plastic parts.** They contain chemicals that can damage, weaken, or destroy plastic.

WARNING:

Some dust created by power sanding, sawing, grinding, drilling, and other construction activities contains chemicals known to cause cancer, birth defects or other reproductive harm. Some examples of these chemicals are:

- lead from lead-based paints,
- crystalline silica from bricks and cement and other masonry products, and
- arsenic and chromium from chemically-treated lumber.

Your risk from these exposures varies, depending on how often you do this type of work. To reduce your exposure to these chemicals: work in a well ventilated area, and work with approved safety equipment, such as those dust masks that are specially designed to filter out microscopic particles.

- **An extension cord should not be used unless absolutely necessary.** Use of improper extension cord could result in a risk of fire and electric shock. If extension cord must be used, make sure:

- a. That pins on plug of extension cord are the same number, size and shape as those of plug on charger.
- b. That extension cord is properly wired and in good electrical condition; and
- c. That wire size is large enough for AC ampere rating of charger as specified below:











Cord Length (Feet)	25'	50'	100'
Cord Size (AWG)	16	16	16

NOTE: AWG = American Wire Gauge

- **Do not operate charger with a damaged cord or plug**, which could cause shorting and electric shock. If damaged, have the charger replaced by an authorized serviceman.
- **Do not operate charger if it has received a sharp blow, been dropped, or otherwise damaged in any way.** Take it to an authorized serviceman for electrical check to determine if the charger is in good working order.
- **Do not disassemble charger.** Take it to an authorized serviceman when service or repair is required. Incorrect reassembly may result in a risk of electric shock or fire.
- **Unplug charger from outlet before attempting any maintenance or cleaning to reduce the risk of electric shock.**
- **Disconnect charger from the power supply when not in use.** This will reduce the risk of electric shock or damage to the charger if metal items should fall into the opening. It also will help prevent damage to the charger during a power surge.
- **Risk of electric shock.** Do not touch uninsulated portion of output connector or uninsulated battery terminal.
- **Save these instructions.** Refer to them frequently and use them to instruct others who may use this tool. If you loan someone this tool, loan them these instructions also to prevent misuse of the product and possible injury.



SYMBOLS

Some of the following symbols may be used on this tool. Please study them and learn their meaning. Proper interpretation of these symbols will allow you to operate the tool better and safer.

SYMBOL	NAME	DESIGNATION/EXPLANATION
V	Volts	Voltage
A	Amperes	Current
Hz	Hertz	Frequency (cycles per second)
W	Watt	Power
min	Minutes	Time
~	Alternating Current	Type of current
==	Direct Current	Type or a characteristic of current
n_0	No Load Speed	Rotational speed, at no load
	Class II Construction	Double-insulated construction
.../min	Per Minute	Revolutions, strokes, surface speed, orbits etc., per minute
	Wet Conditions Alert	Do not expose to rain or use in damp locations.
	Read The Operator's Manual	To reduce the risk of injury, user must read and understand operator's manual before using this product.
	Eye Protection	Always wear safety goggles or safety glasses with side shields and a full face shield when operating this product.
	Safety Alert	Precautions that involve your safety.
	No Hands Symbol	Failure to keep your hands away from the blade will result in serious personal injury.
	No Hands Symbol	Failure to keep your hands away from the blade will result in serious personal injury.
	No Hands Symbol	Failure to keep your hands away from the blade will result in serious personal injury.
	No Hands Symbol	Failure to keep your hands away from the blade will result in serious personal injury.
	Hot Surface	To reduce the risk of injury or damage, avoid contact with any hot surface.

SYMBOLS

The following signal words and meanings are intended to explain the levels of risk associated with this product.

SYMBOL	SIGNAL	MEANING
	DANGER:	Indicates an imminently hazardous situation, which, if not avoided, will result in death or serious injury.
	WARNING:	Indicates a potentially hazardous situation, which, if not avoided, could result in death or serious injury.
	CAUTION:	Indicates a potentially hazardous situation, which, if not avoided, may result in minor or moderate injury.
	CAUTION:	(Without Safety Alert Symbol) Indicates a situation that may result in property damage.

SERVICE

Servicing requires extreme care and knowledge and should be performed only by a qualified service technician. For service we suggest you return the product to your nearest **AUTHORIZED SERVICE CENTER** for repair. When servicing, use only identical replacement parts.



WARNING:

To avoid serious personal injury, do not attempt to use this product until you read thoroughly and understand completely the operator's manual. Save this operator's manual and review frequently for continuing safe operation and instructing others who may use this product.



WARNING:



The operation of any power tool can result in foreign objects being thrown into your eyes, which can result in severe eye damage. Before beginning power tool operation, always wear safety goggles or safety glasses with side shields and a full face shield when needed. We recommend Wide Vision Safety Mask for use over eyeglasses or standard safety glasses with side shields. Always use eye protection which is marked to comply with ANSI Z87.1.

SAVE THESE INSTRUCTIONS

FEATURES

PRODUCT SPECIFICATIONS

Motor 18 Volt DC
 Blade Diameter 5-1/2 in.
 Blade Arbor 3/8 in.
 Cutting Depth at 0° 1-9/16 in.
 Cutting Depth at 45° 1-1/8 in.

Charger Input 120 V, 60 Hz, AC Only
 Charge Rate 1 Hour
 No Load Speed 4200/min.
 Laser Guide Class II, <1mW max, 650 nm

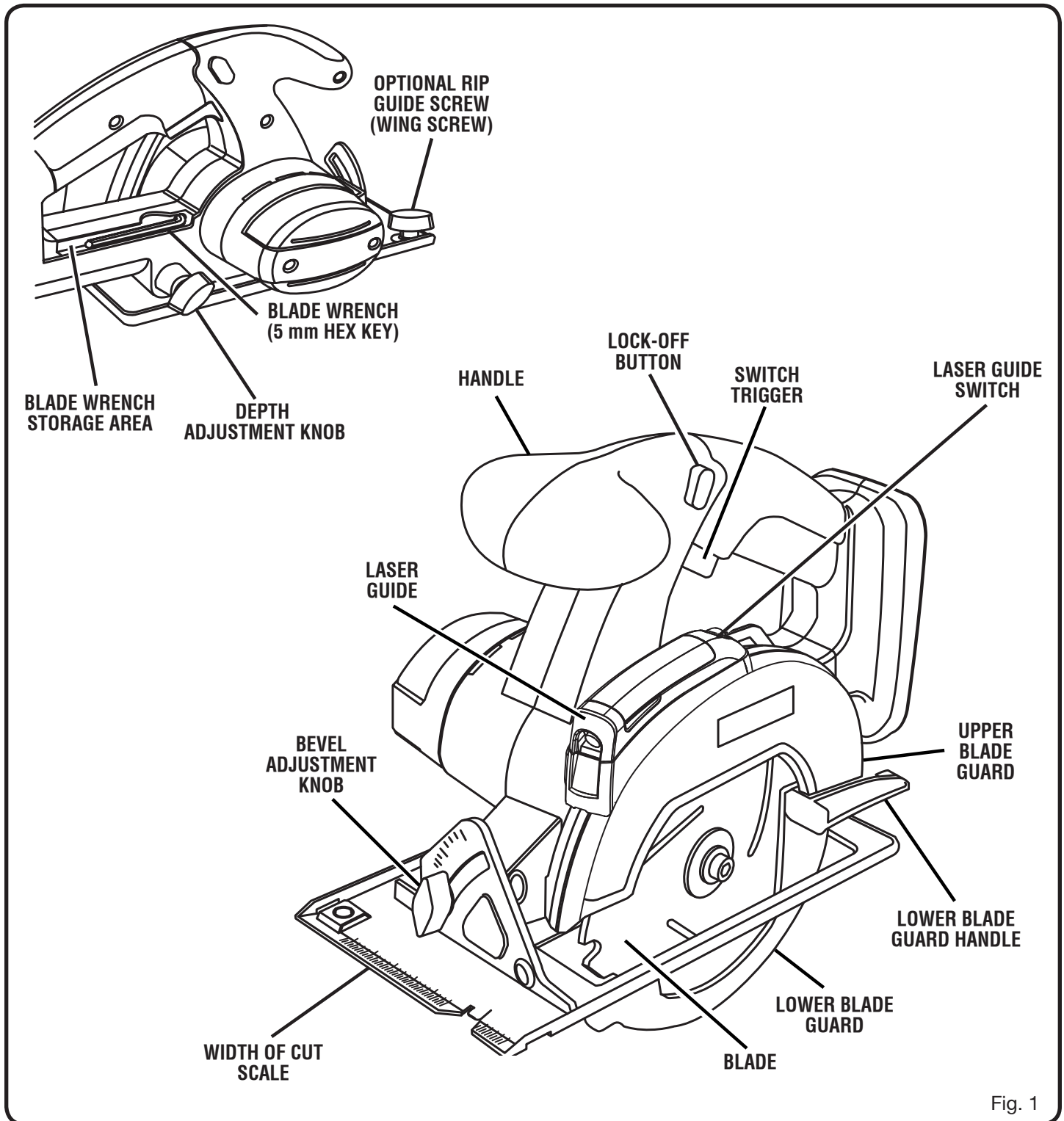

Fig. 1

FEATURES

KNOW YOUR LASER CIRCULAR SAW

See Figure 1.

Before attempting to use this product, familiarize yourself with all operating Features and Safety Rules.

SWITCH TRIGGER

The saw has a conveniently located switch trigger on the underside of the handle.

SPINDLE LOCK

The spindle lock allows you to secure the blade when turning the blade screw.

NOTE: Do not run the circular saw with spindle lock engaged.

BLADE WRENCH STORAGE

Convenient wrench storage for quick blade changes.

LOCK-OFF BUTTON

The lock-off button reduces the possibility of accidental starting.

BEVEL ADJUSTMENT KNOB

The bevel adjustment feature allows you to make bevel cuts of 45° and 90°.

WIDTH OF CUT SCALE

When making straight cross cuts or rip cuts, the scale can be used to measure up to four inches to the right side of the blade. It can be used to measure up to one inch to the left side of the blade.

LASER GUIDE

The laser guide will generate a red colored line on the work surface when turned on.

ASSEMBLY

UNPACKING

This product requires assembly.

- Carefully remove the tool and any accessories from the box. Make sure that all items listed in the packing list are included.
- Inspect the tool carefully to make sure no breakage or damage occurred during shipping.
- Do not discard the packing material until you have carefully inspected and satisfactorily operated the tool.
- If any parts are damaged or missing, please call 1-800-525-2579 for assistance.

PACKING LIST

Circular Saw with Laser
5-1/2 in. Blade
Blade Wrench
AAA batteries (2)
Lanyard (not included in combo)
Operator's Manual
Warranty Registration Card



WARNING:

If any parts are missing do not operate this tool until the missing parts are replaced. Failure to do so could result in possible serious personal injury.



WARNING:

Do not attempt to modify this tool or create accessories not recommended for use with this tool. Any such alteration or modification is misuse and could result in a hazardous condition leading to possible serious personal injury.



WARNING:

To prevent accidental starting that could cause serious personal injury, always remove the battery pack from the tool when assembling parts.

ASSEMBLY

ATTACHING THE BLADE

See Figure 2.

WARNING:

A 5-1/2 in. blade is the maximum blade capacity of the saw. Never use a blade that is too thick to allow outer blade washer to engage with the flats on the spindle. Larger blades will come in contact with the blade guard, while thicker blades will prevent blade screw from securing blade on spindle. Either of these situations could result in a serious accident.

- Remove the battery pack from the saw.
- Remove the blade wrench (5 mm hex key) from the storage area.
- Depress the spindle lock button and remove the blade screw and outer blade washer.

NOTE: Turn the blade screw clockwise to remove.

CAUTION:

To prevent damage to the spindle or spindle lock, always allow motor to come to a complete stop before engaging spindle lock.

- Wipe a drop of oil onto the inner blade washer and outer blade washer where they contact the blade.

WARNING:

If inner blade washer has been removed, replace it before placing blade on spindle. Failure to do so could cause an accident since blade will not tighten properly.

- Fit the saw blade inside the lower blade guard and onto the spindle.
NOTE: The saw teeth point upward at the front of the saw.
- Replace the outer blade washer.
- Depress the spindle lock button, then replace the blade screw. Tighten the blade screw securely by turning it clockwise.
- Return the blade wrench to the storage area.

NOTE: Never use a blade that is too thick to allow the outer blade washer to engage with the flats on the spindle.

REMOVING THE BLADE

See Figure 3.

- Remove the battery pack from the saw.
- Remove the blade wrench from the storage area.

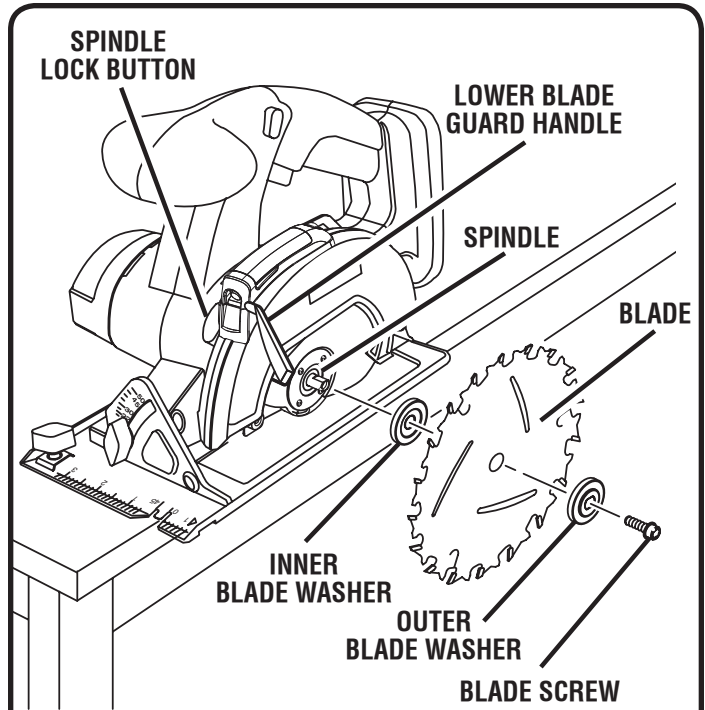

Fig. 2

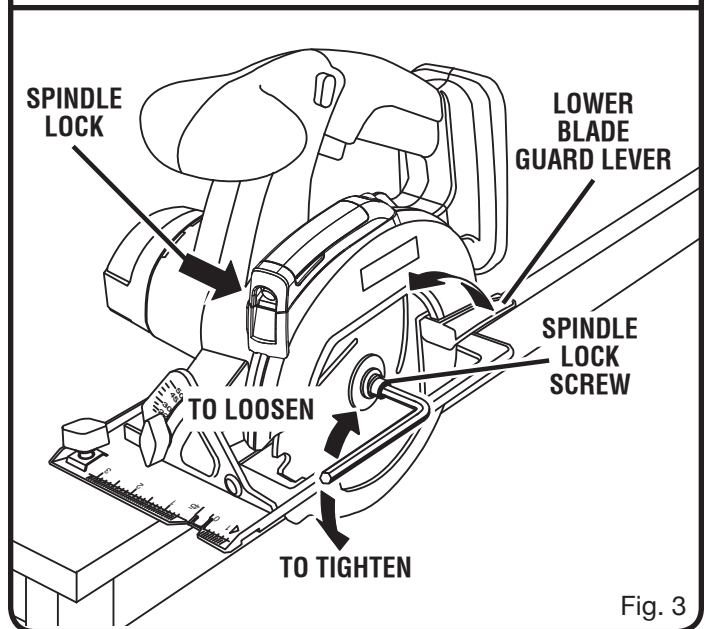

Fig. 3

- Position the saw as shown, depress the spindle lock button, and remove the blade screw by turning it clockwise.
- Remove the outer blade washer.
- Remove the blade.

OPERATION

WARNING:

Do not allow familiarity with tools to make you careless. Remember that a careless fraction of a second is sufficient to inflict serious injury.

WARNING:

Always wear safety goggles or safety glasses with side shields when operating tools. Failure to do so could result in objects being thrown into your eyes, resulting in possible serious injury.

APPLICATIONS

You may use this tool for the following purposes:

- Cutting all types of wood products (lumber, plywood, paneling)
- Cross Cutting/Rip Cutting
- Bevel Cutting
- Pocket Cutting

CAUTION:

To prevent damage to the battery pack, remove the battery pack from the charger immediately if no LED comes on. Return the battery pack and charger to your nearest service center for checking or replacing. Also, if you are removing the battery pack from the charger and no LEDs are on, return both the battery pack and the charger to your nearest service center. Do not insert another battery pack into the charger. A damaged charger may damage a battery pack.

LED FUNCTIONS OF CHARGER

LED WILL BE ON TO INDICATE STATUS OF CHARGER AND BATTERY PACK:

- Red LED on = Fast charging mode.
- Green LED on = Fully charged and in trickle charge mode.
- Green LED on = When battery pack is inserted into charger, indicates hot battery pack or that battery pack is out of or below normal temperature range.
- Yellow and Green LEDs on = Deeply discharged or defective battery pack.
- No LED on = Defective charger or battery pack.

CHARGING THE BATTERY PACK

Battery packs for this tool are shipped in a low charge condition to prevent possible problems. Therefore, you should charge it until the green LED on the front of the charger comes on.

NOTE: Batteries will not reach full charge the first time they are charged. Allow several cycles (operation followed by recharging) for them to become fully charged.

CHARGING A COOL BATTERY PACK

If battery pack is within normal temperature range, the red LED on charger will come on.

NOTE: If the charger does not charge the battery pack under normal circumstances, return both the battery pack and charger to your nearest Ryobi Authorized Service Center for electrical check.

- Charge the battery pack only with a recommended charger.
- Make sure the power supply is normal household voltage, **120 volts, 60 Hz, AC only**.
- Connect the charger to the power supply.
- Place the battery pack in the charger aligning raised rib on the battery pack with the groove in the charger. *See Figure 4.*
- Press down on the battery pack to be sure contacts on the battery pack engage properly with contacts in the charger.
- Normally the red LED on charger will come on. This indicates the charger is in fast charging mode.
- Red LED should remain on for approximately 1 hour then the green LED will come on. Green LED on indicates battery pack is fully charged and charger is in maintenance charge mode.

NOTE: The green LED will remain on until the battery pack is removed from the charger or charger is disconnected from the power supply.

- If both yellow and green LEDs come on, this indicates a deeply discharged or defective battery pack. Allow the battery pack to remain in the charger for 15 to 30 minutes. When the battery pack reaches normal voltage range, the red LED should come on. If the red LED does not come on after 30 minutes, this may indicate a defective battery pack and should be replaced.
- After normal usage, a minimum of 1 hour of charging time is required to fully recharge battery pack.
- The battery pack will become slightly warm to the touch while charging. This is normal and does not indicate a problem.
- Do not place the charger and battery pack in an area of extreme heat or cold. They will work best at normal room temperature.
NOTE: The charger and battery pack should be placed in a location where the temperature is more than 50°F but less than 100°F.
- When batteries become fully charged, unplug the charger from the power supply and remove the battery pack.

OPERATION

CHARGING A HOT BATTERY PACK

When using the tool continuously, the batteries in the battery pack will become hot. You should let a hot battery pack cool down for approximately 30 minutes before attempting to recharge. When the battery pack becomes discharged and is hot, this will cause the green LED to come on instead of the red LED. After 30 minutes, reinsert the battery pack in the charger. If the green LED continues to remain on, return battery pack to your nearest Ryobi Authorized Service Center for checking or replacing.

NOTE: This situation only occurs when continuous use of the tool causes the batteries to become hot. It does not occur under normal circumstances. Refer to “**CHARGING A COOL BATTERY PACK**” for normal recharging of batteries. If the charger does not charge your battery pack under normal circumstances, return both the battery pack and charger to your nearest Ryobi Authorized Service Center for electrical check.

INSTALLING THE BATTERY PACK

See Figure 5.

NOTE: The battery pack is shipped in a low charge condition. Therefore, it must be charged prior to use. Refer to page 12, “**CHARGING BATTERY PACK**” for charging instructions.

- Place the battery pack in the saw. Align the raised rib on the battery pack with the groove inside the saw, then slide the battery pack into the saw.
- Make sure the latches on each side of your battery pack snap into place and the battery pack is secured in the saw before beginning operation.

CAUTION:

When placing battery pack in the tool, be sure raised rib on battery pack aligns with the bottom of the tool and latches into place properly. Improper installation of the battery pack can cause damage to internal components.

REMOVING THE BATTERY PACK

See Figure 5.

- Locate the latches on the side of the battery pack and depress them to release the battery pack from the saw.
- Remove battery pack from your saw.

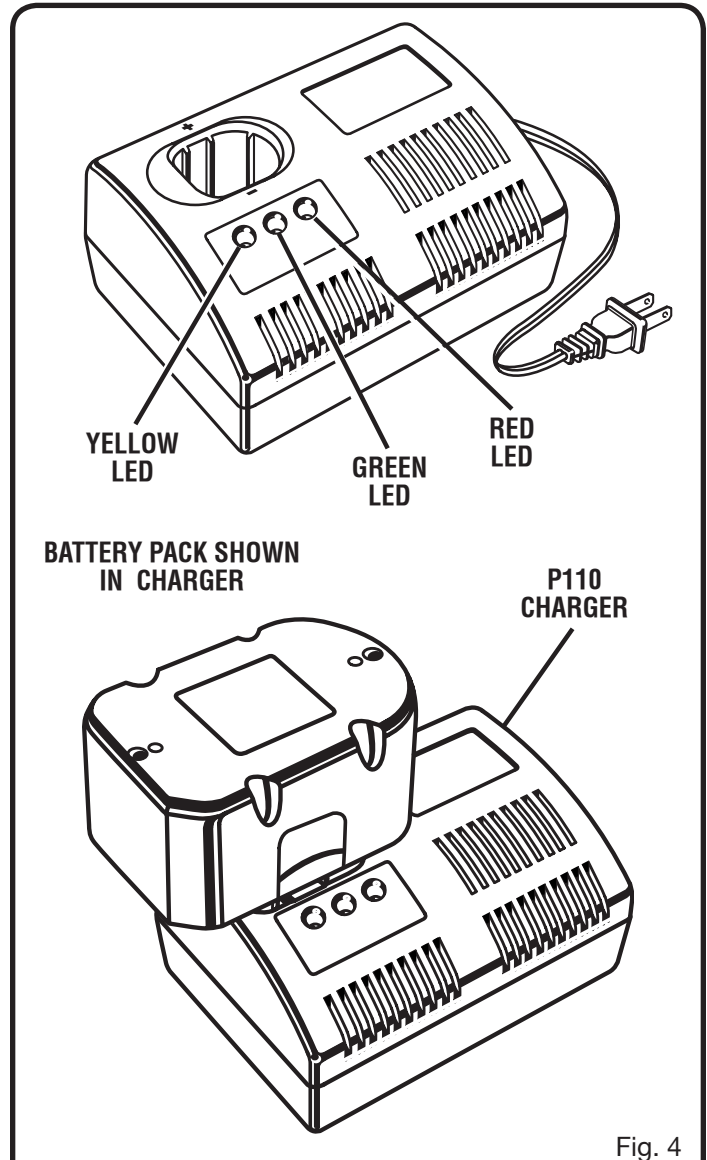

Fig. 4

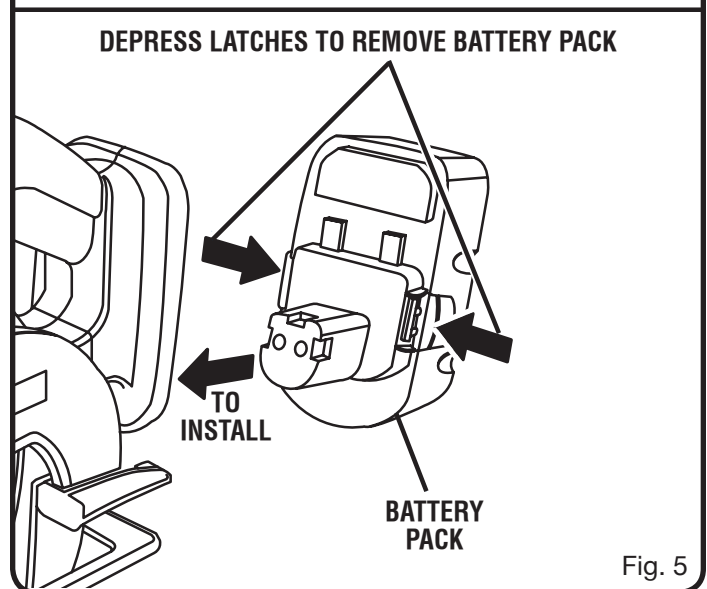

Fig. 5

OPERATION

WARNING:

Battery tools are always in operating condition. Therefore, switch should always be locked when not in use or carrying at your side.

KICKBACK

See Figures 6 - 9.

Kickback occurs when the blade stalls rapidly and the saw is driven back towards you. Blade stalling is caused by any action which pinches the blade in the wood.

DANGER:

Release switch immediately if blade binds or saw stalls. Kickback could cause you to lose control of the saw. Loss of control can lead to serious injury.

To guard against kickback, avoid dangerous practices such as the following.

- Setting blade depth incorrectly.
- Sawing into knots or nails in workpiece.
- Twisting the blade while making a cut.
- Making a cut with a dull, gummed up, or improperly set blade.
- Supporting the workpiece incorrectly.
- Forcing a cut.
- Cutting warped or wet lumber.
- Operating the tool incorrectly or misusing the tool.

To lessen the chance of kickback, follow these safety practices.

- Keep the blade at the correct depth setting. The depth setting should not exceed 1/4 in. below the material being cut.
- Inspect the workpiece for knots or nails before cutting. Never saw into a knot or nail.
- Make straight cuts. Always use a straight edge guide when rip cutting. This helps prevent twisting the blade.
- Use clean, sharp, and properly set blades. Never make cuts with dull blades.
- Support the workpiece properly before beginning a cut.
- Use steady, even pressure when making a cut. Never force a cut.
- Do not cut warped or wet lumber.
- Hold the saw firmly with both hands and keep your body in a balanced position so as to resist the forces if kickback should occur.

WARNING:

When using the saw, always stay alert and exercise control. Do not remove the saw from the workpiece while the blade is moving.

KICKBACK - BLADE SET TOO DEEP

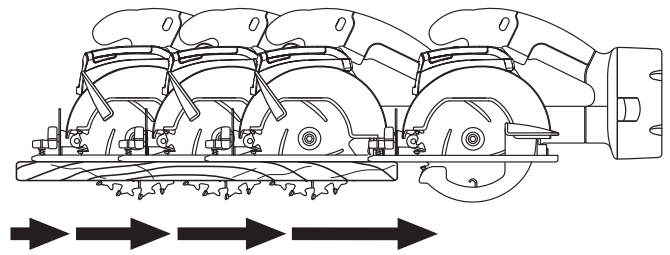

Fig. 6

INCORRECT SUPPORT

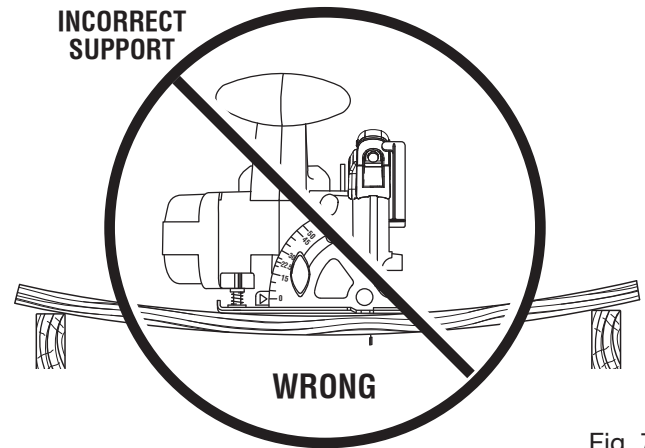

Fig. 7

CORRECT BLADE DEPTH SETTING = BLADE EXPOSED 1/4 in. (6.35 mm) OR LESS ON UNDERSIDE OF WORKPIECE

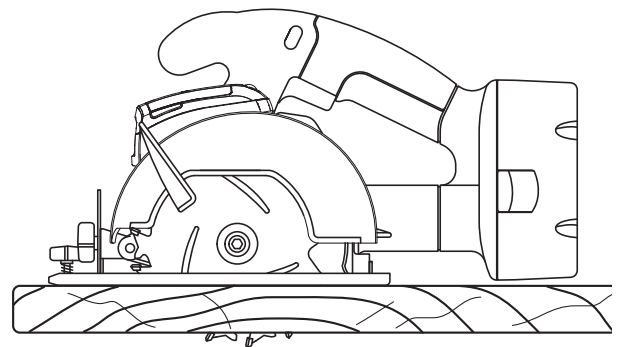

Fig. 8

CORRECT SUPPORT

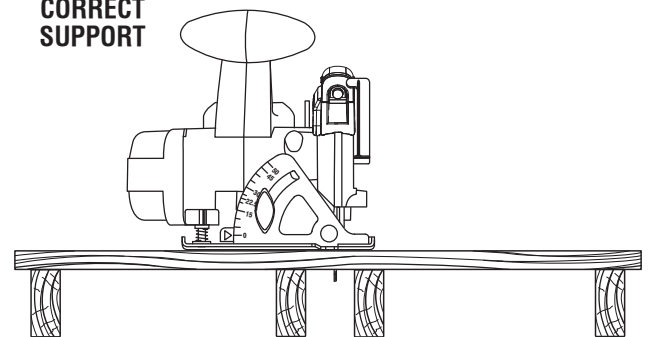

Fig. 9

OPERATION

SAW BLADES

The best of saw blades will not cut efficiently if they are not kept clean, sharp, and properly set. Using a dull blade will place a heavy load on the saw and increase the danger of kickback. Keep extra blades on hand, so that sharp blades are always available.

Gum and wood pitch hardened on blades will slow the saw down. Remove saw blade from the saw and use gum and pitch remover, hot water, or kerosene to remove these accumulations. **DO NOT USE GASOLINE.**

BLADE GUARD SYSTEM

See Figure 10.

The lower blade guard attached to your circular saw is there for your protection and safety. Do not alter it for any reason. If it becomes damaged, do not operate the saw until you have the guard repaired or replaced. Always leave guard in operating position when using the saw.

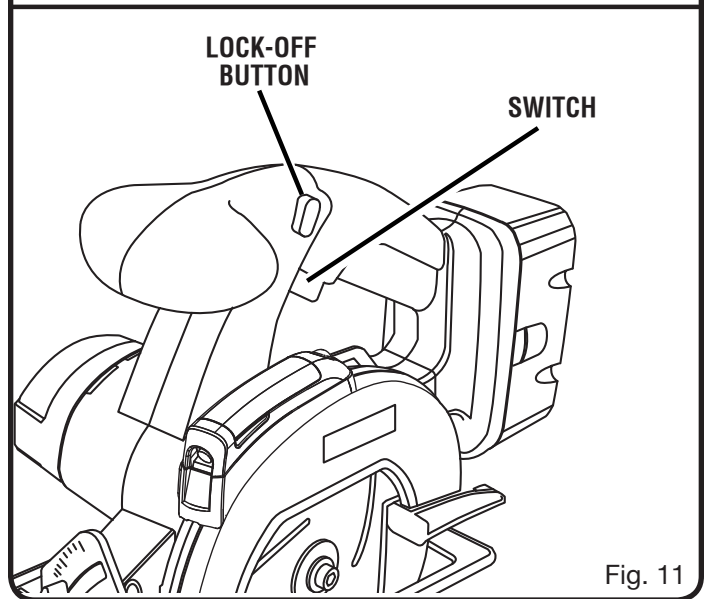
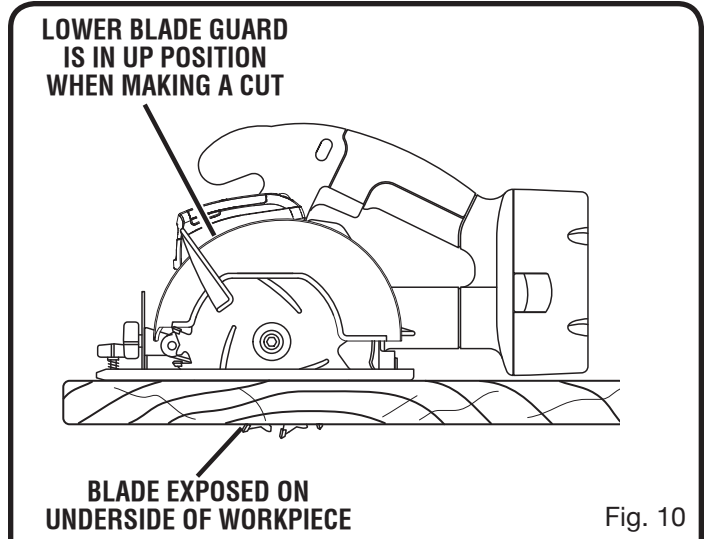

⚠ DANGER:

When sawing through work, lower blade guard does not cover blade on the underside of work. Since blade is exposed on underside of work, keep hands and fingers away from cutting area. Any part of your body coming in contact with moving blade will result in serious injury.

⚠ CAUTION:

Never use saw when guard is not operating correctly. Check the guard for correct operation before each use. The guard is operating correctly when it moves freely and readily returns to the closed position. If you drop the saw, check the lower blade guard and bumper for damage at all depth settings before reuse.

STARTING/STOPPING THE SAW

See Figure 11.

To start the saw: Depress the switch trigger.

Always let the blade reach full speed, then guide the saw into the workpiece.

⚠ WARNING:

The blade coming in contact with the workpiece before it reaches full speed could cause the saw to “kickback” towards you resulting in serious injury.

To stop the saw: Release the switch trigger.

After you release the switch trigger, allow the blade to come to a complete stop. **Do not remove the saw from the workpiece while the blade is moving.**

LOCK-OFF BUTTON

See Figure 11.

The lock-off button reduces the possibility of accidental starting. The lock-off button is located on the handle above the switch trigger. The lock-off button must be depressed before you pull the switch trigger. The lock resets each time the trigger is released.

NOTE: You can depress the lock-off button from either the left or right side.

OPERATION

ADJUSTING BLADE DEPTH

See Figure 12.

Always keep correct blade depth setting. The correct blade depth setting for all cuts should not exceed 1/4 in. below the material being cut. More blade depth will increase the chance of kickback and cause the cut to be rough. For more depth of cut accuracy, a scale is located on the upper blade guard.

- Loosen the depth adjustment knob.
- Determine the desired depth of cut.
- Locate the depth of cut scale on the back of the upper blade guard.
- Hold the base flat against the workpiece and raise or lower the saw until the indicator mark on bracket aligns with the notch on the blade guard.
- Tighten the depth adjustment knob securely.

USING THE LASER GUIDE

See Figure 13.

WARNING:

Do not stare into the laser beam or turn the laser on when the tool is not in use. Failure to do so could result in possible serious personal injury. The laser unit comes from the factory already installed and aligned. If the laser becomes misaligned after time refer to the "Adjustments" section.

NOTE: Make a trial cut on a piece of scrap to ensure laser is aligned. Adjusting the laser may be necessary.

- Mark the line to be cut on the workpiece.
- Adjust the depth and angle of the cut as needed.
- Switch on the laser beam.
- Install the battery pack into the tool and start the motor.

NOTE: Do not touch the blade to the workpiece until the saw has reached maximum speed.

- Slowly push the saw forward into the workpiece.

NOTE: Keep the laser beam on the marked line on the workpiece for precision cutting.

- Once the cut is complete, allow the saw to come to a complete stop before turning off the laser.

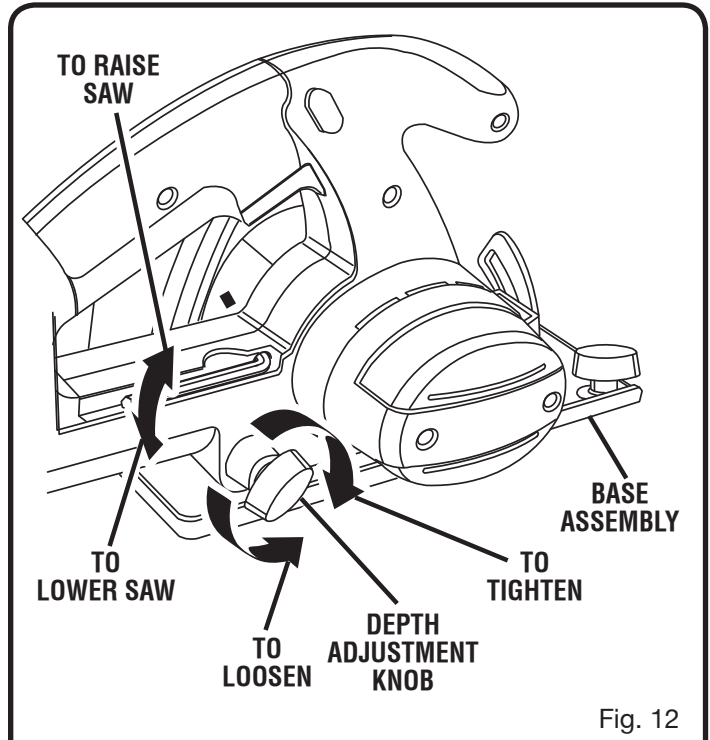

Fig. 12

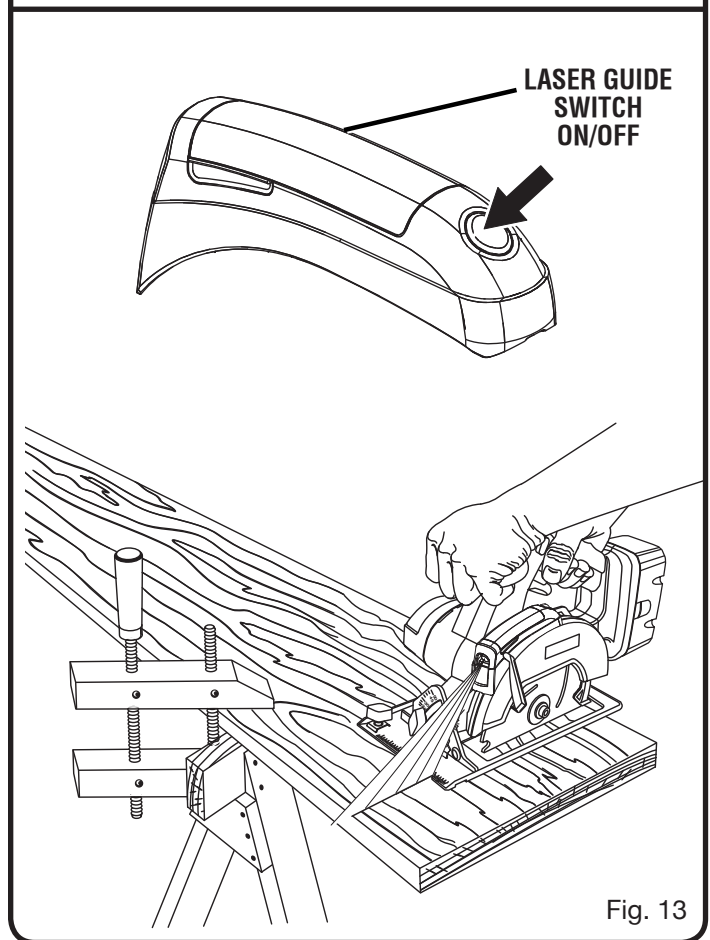

Fig. 13

OPERATION

OPERATING THE SAW

See Figures 14 - 16.

It is important to understand the correct method for operating the saw. Refer to the figures in this section to learn the correct and incorrect ways for handling the saw.

WARNING:

To make sawing easier and safer, always maintain proper control of the saw. Loss of control could cause an accident resulting in possible serious injury.

DANGER:

When lifting the saw from the workpiece, the blade is exposed on the underside of the saw until the lower blade guard closes. Make sure the lower blade guard is closed before setting the saw down.

To make the best possible cut, follow these helpful hints.

- Hold the saw firmly with both hands.
- Avoid placing your hand on the workpiece while making a cut.
- Support the workpiece so that the cut (kerf) is always to your side.
- Support the workpiece near the cut.
- Clamp the workpiece securely so that the workpiece will not move during the cut.
- Always place the saw on the workpiece that is supported, not the “cut off” piece.
- Place the workpiece with the “good” side down.
- Draw a guideline along the desired line of cut before beginning your cut.
- Keep the cord away from the cutting area. Always place the cord to prevent it from hanging up on the workpiece while making a cut.

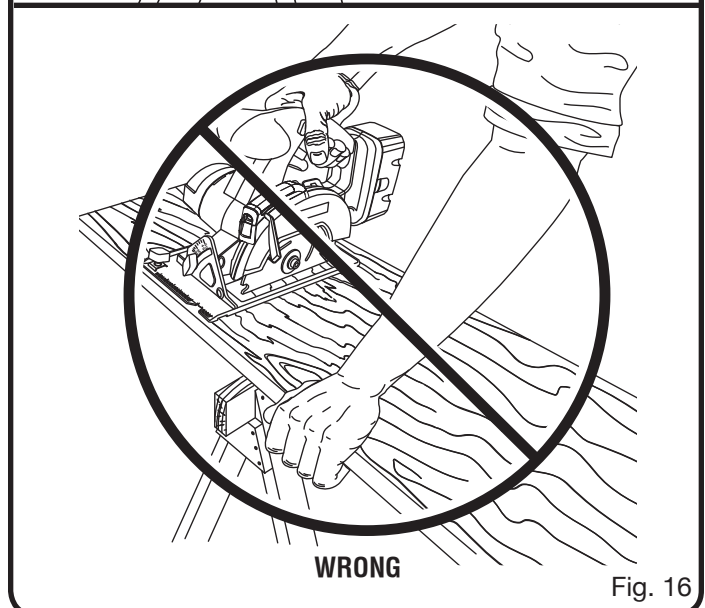
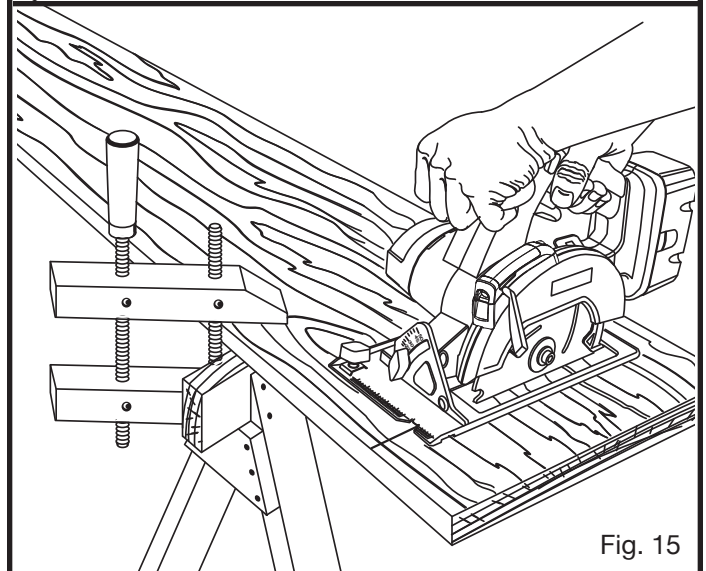
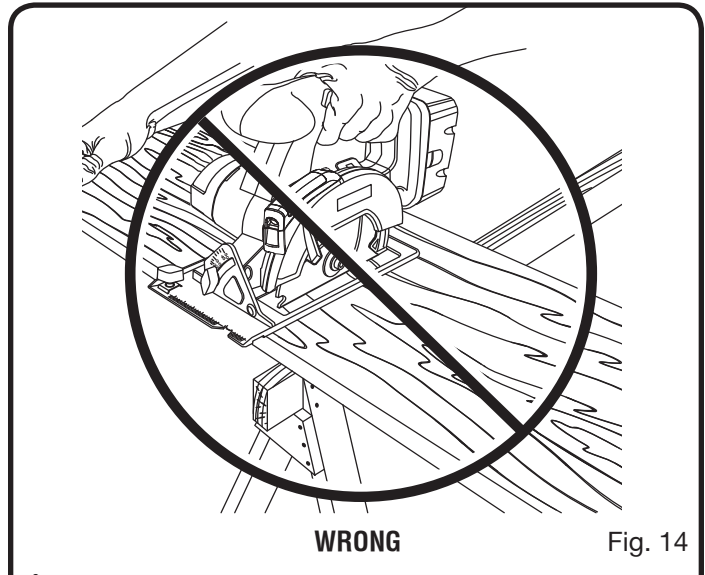

CROSS CUTTING/RIP CUTTING

See Figure 17.

When making a cross cut or rip cut, align the line of cut with the outer blade guide notch on the base.

Since blade thicknesses vary, always make a trial cut in scrap material along a guideline to determine how much, if any, you must offset the guideline to produce an accurate cut.

NOTE: The distance from the line of cut to the guideline is the amount you should offset the guide.

RIP CUTTING

See Figure 18.

Use a guide when making long or wide rip cuts with the saw.

- Secure the workpiece.
- Clamp a straight edge to the workpiece using C-clamps.
- Saw along the straight edge to achieve a straight rip cut.

NOTE: Do not bind the blade in the cut.

WIDTH OF CUT SCALE

See Figure 19.

A width of cut scale has been provided on the base of your saw. When making straight cross cuts or rip cuts, the scale can be used to measure up to four inches to the right side of the blade. It can be used to measure up to one inch to the left side of the blade.

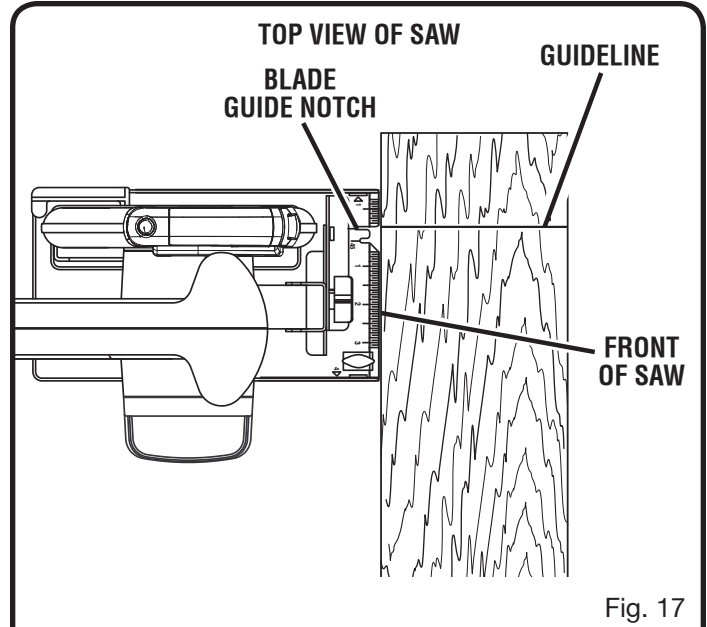

Fig. 17

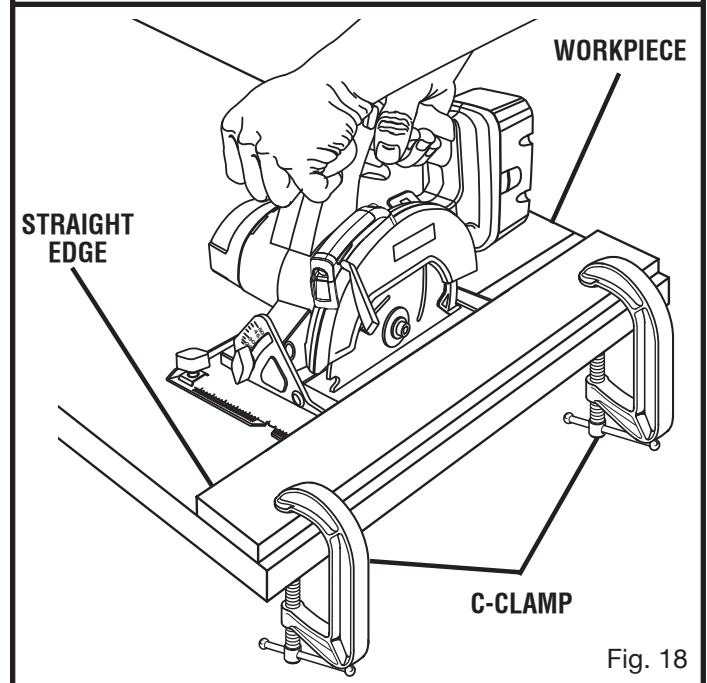

Fig. 18

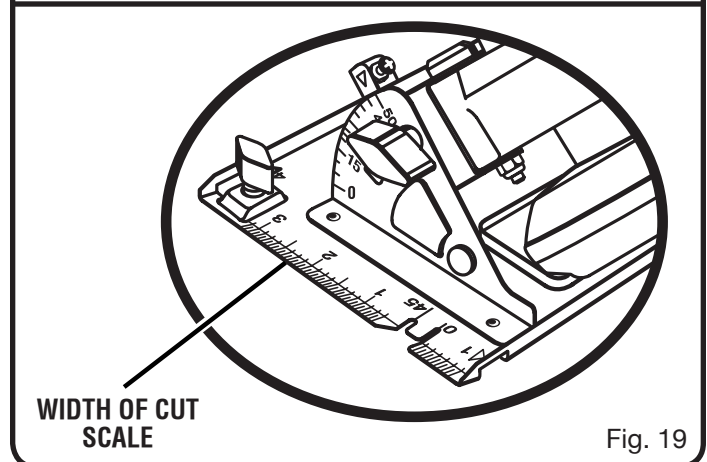

Fig. 19

OPERATION

BEVEL CUTTING

See Figures 20 - 22.

- Align the line of cut with the inner blade guide notch on the base when making 45° bevel cuts.
- Make a trial cut in scrap material along a guideline to determine how much you should offset the guideline on the cutting material.
- Adjust the angle of the cut to any desired setting between zero and 51.5°. Refer to “Adjusting the Bevel Setting” next.

NOTE: When making bevel cuts, you may need to re-adjust the laser. (See “Adjusting the Laser.”)

ADJUSTING THE BEVEL SETTING

See Figure 21.

- Loosen the bevel adjustment knob.
- Raise the motor housing end of the saw until you reach the desired angle setting on the bevel scale.
- Tighten the bevel adjustment knob securely.



WARNING:

Attempting a bevel cut without having the bevel adjustment knob securely tightened can result in serious injury.

MAKING A BEVEL CUT

See Figure 22.

- Hold the saw firmly with both hands as shown.
- Rest the front edge of the base on the workpiece.
- Start the saw and let the blade reach full speed.
- Guide the saw into the workpiece and make the cut.
- Release the trigger and allow the blade to come to a complete stop.
- Lift the saw from the workpiece.

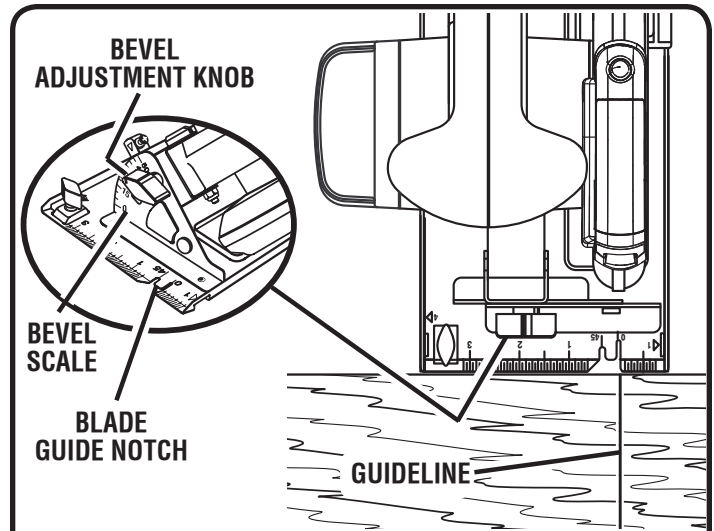

Fig. 20

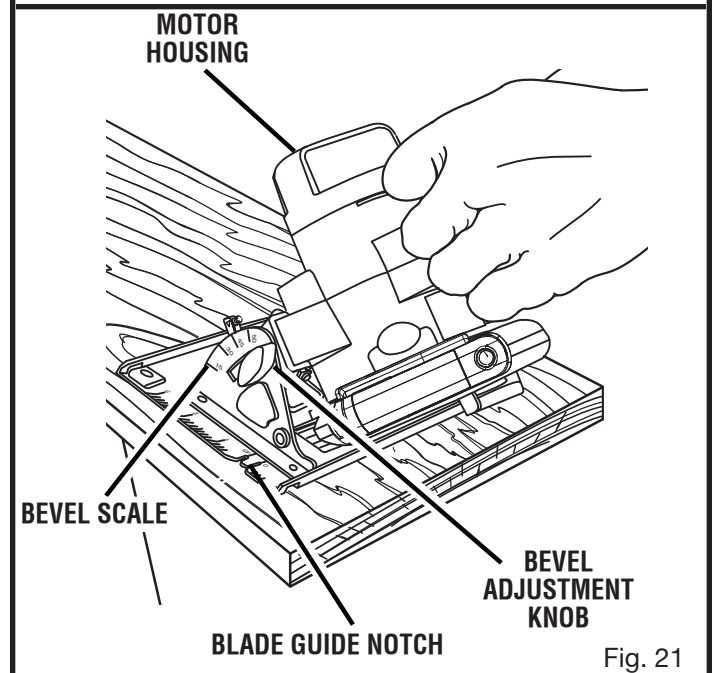

Fig. 21

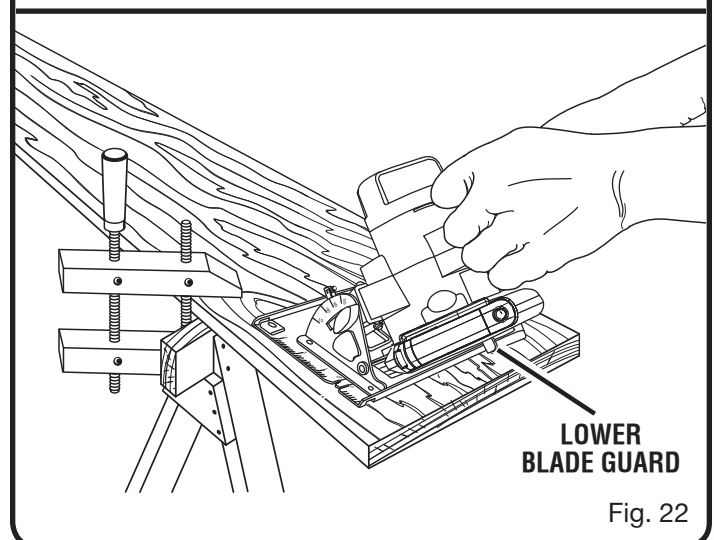

Fig. 22

OPERATION

POCKET CUTTING

See Figure 23.

WARNING:

Always adjust bevel setting to zero before making a pocket cut. Attempting a pocket cut at any other setting can result in loss of control of the saw possibly causing serious injury.

- Adjust the bevel setting to zero.
- Set the blade to the correct blade depth setting.
- Swing the lower blade guard up using the lower blade guard handle.
NOTE: Always raise the lower blade guard with the handle to avoid serious injury.
- Hold the lower blade guard by the handle.
- Rest the front of the base flat against the workpiece with the rear of the handle raised so the blade does not touch the workpiece.
- Start the saw and let the blade reach full speed.
- Guide the saw into the workpiece and make the cut.

WARNING:

Always cut in a forward direction when pocket cutting. Cutting in the reverse direction could cause the saw to climb up on the workpiece and back toward you.

- Release the trigger and allow the blade to come to a complete stop.
- Lift the saw from the workpiece.
- Clear corners out with a hand saw or sabre saw.

WARNING:

Never tie the lower blade guard in a raised position. Leaving the blade exposed could lead to serious injury.

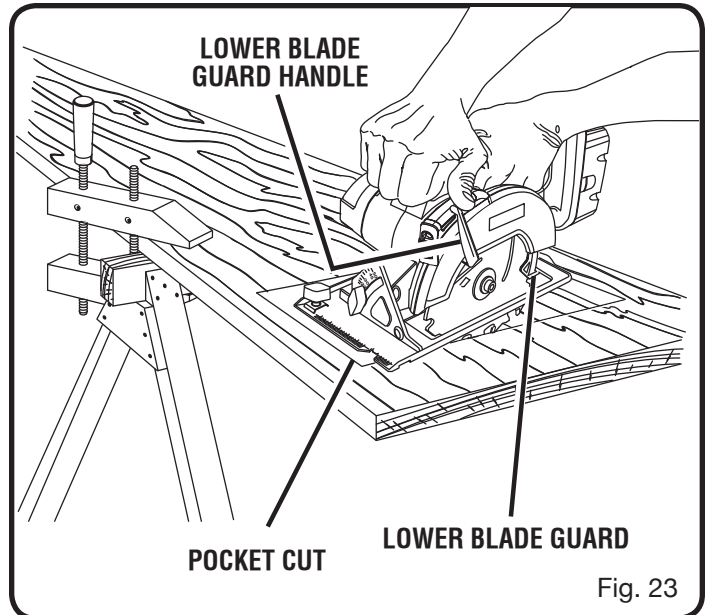

Fig. 23

ADJUSTMENTS

WARNING:

Before performing any adjustment, make sure the battery pack is removed from tool and the switch is in the OFF position. Failure to heed this warning could result in serious personal injury.

POSITIVE 0° BEVEL STOP

See Figure 24.

The saw has a positive 0° bevel stop that has been factory adjusted to assure 0° angle of the saw blade when making 90° cuts.

CHECKING POSITIVE 0° BEVEL STOP

- Place the saw in an upside down position on a workbench.
- Check the squareness of the saw blade to the base of the saw using a carpenter's square.

ADJUSTING POSITIVE 0° BEVEL STOP

- Loosen bevel adjustment knob.
- Turn setscrew with hex key and adjust base until it is square with the saw blade.
- Tighten bevel adjustment knob securely.

WARNING:

Attempting a bevel cut without having the bevel adjustment knob securely tightened can result in serious injury.

ADJUSTING THE LASER

See Figure 25.

NOTE: Draw a pencil line on a scrap workpiece parallel to the long edge of the base as a straight line guide to aid in the adjusting process.

- Make sure the laser is turned off.
- Remove the laser cover by lifting it off its base.
- Turn the laser on.
- Loosen the screw inside the laser.
- Rest the front of the base on a scrap workpiece.
- Adjust the laser beam with the mark on the scrap workpiece by loosening the screw to the laser aperture and slowly moving the laser guide left or right.
- Since blade thicknesses vary, always make a trial cut in scrap workpiece to ensure an accurate cut.
- Once alignment is achieved, tighten the screw.
- Replace the laser cover.
- Check for proper alignment.
- Repeat as necessary until the laser is aligned.

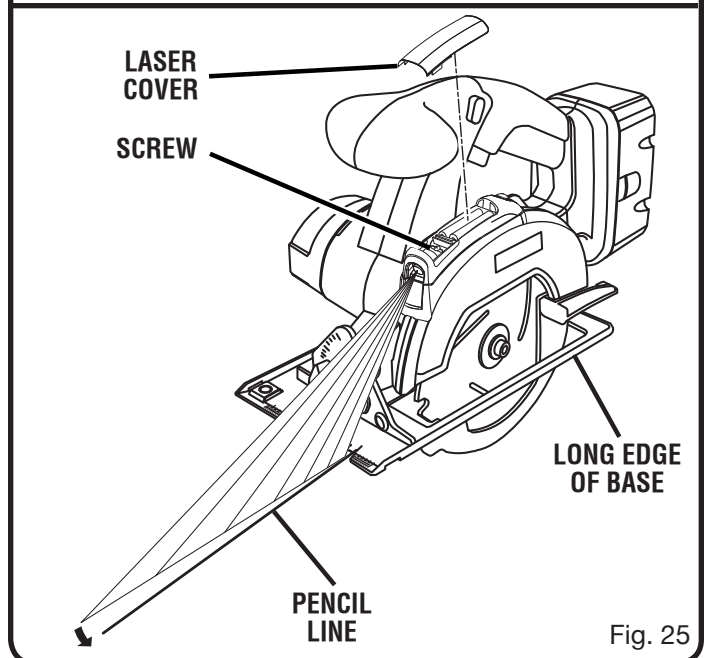
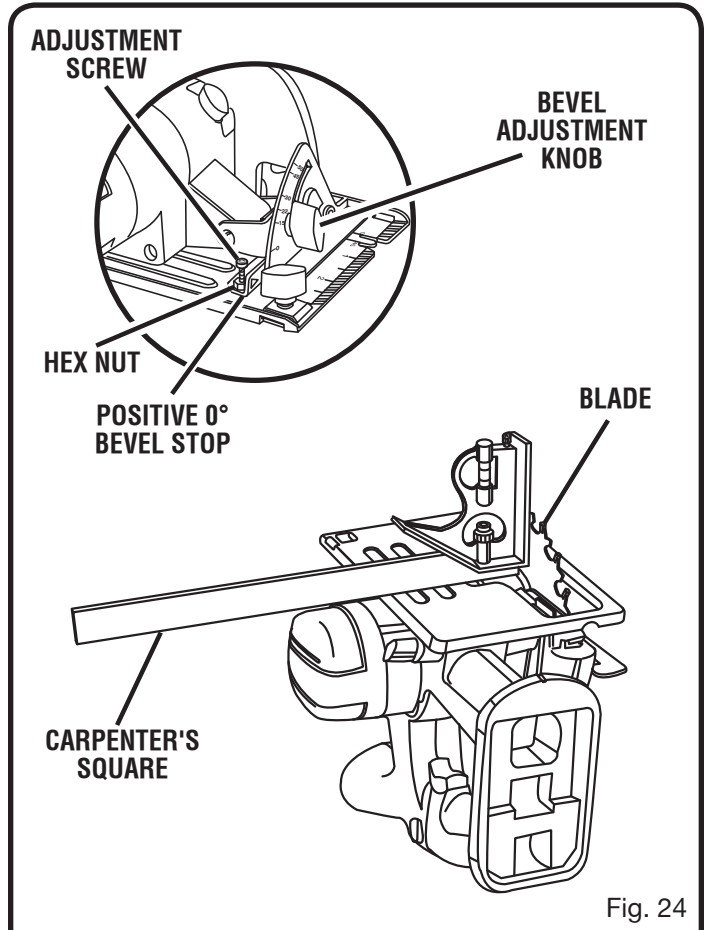

MAINTENANCE

WARNING:

When servicing, use only identical Ryobi replacement parts. Use of any other parts may create a hazard or cause product damage.

WARNING:

Always wear safety goggles or safety glasses with side shields during power tool operation or when blowing dust. If operation is dusty, also wear a dust mask.

WARNING:

To avoid serious personal injury, always remove the battery pack from the tool when cleaning or performing any maintenance.

GENERAL MAINTENANCE

Avoid using solvents when cleaning plastic parts. Most plastics are susceptible to damage from various types of commercial solvents and may be damaged by their use. Use clean cloths to remove dirt, dust, oil, grease, etc.

WARNING:

Do not at any time let brake fluids, gasoline, petroleum-based products, penetrating oils, etc., come in contact with plastic parts. Chemicals can damage, weaken or destroy plastic which may result in serious personal injury.

Only the parts shown on the parts list are intended to be repaired or replaced by the customer. All other parts should be replaced at a Ryobi Authorized Service Center.

REPLACING LASER GUIDE BATTERIES

See Figure 26.

- Remove the battery pack from the saw.
- Make sure the laser is turned off.
- Remove the laser cover by lifting it off its base.
- Remove both AAA batteries.
- Install the two AAA batteries, aligning the positives (+) with positives (+) and the negatives (-) with negatives (-) as shown on the inside base of the laser.
- Replace the laser cover.
- Turn on the laser.

CAUTION:

Use of controls or adjustments or performance other than those specified herein may result in hazardous radiation exposure.

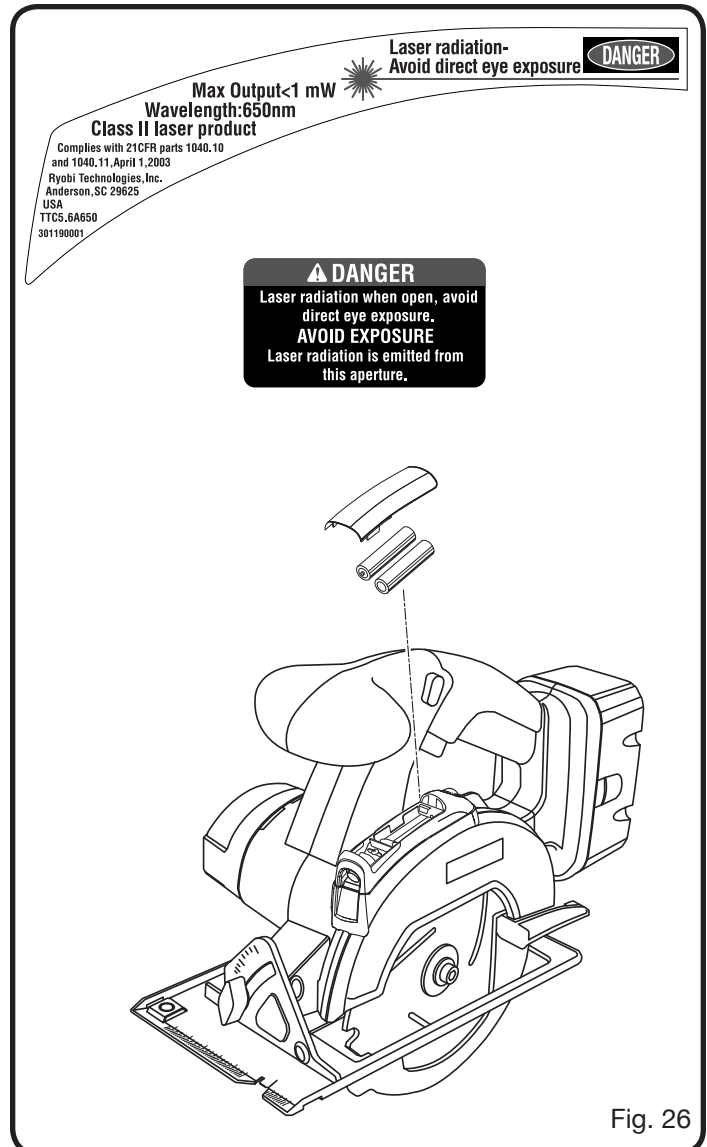

MAINTENANCE

BATTERIES

The battery pack for this tool is equipped with nickel-cadmium rechargeable batteries. Length of service from each charging will depend on the type of work you are doing.

The batteries in this tool have been designed to provide maximum trouble-free life. However, like all batteries, they will eventually wear out. **Do not** disassemble battery pack and attempt to replace the batteries. Handling of these batteries, especially when wearing rings and jewelry, could result in a serious burn.

To obtain the longest possible battery life, we suggest the following:

- Remove the battery pack from the charger once it is fully charged and ready for use.

For battery storage longer than 30 days:

- Store the battery pack where the temperature is below 80°F.
- Store battery packs in a "discharged" condition.

BATTERY PACK REMOVAL AND PREPARATION FOR RECYCLING



To preserve natural resources, please recycle or dispose of batteries properly.

This product contains nickel-cadmium batteries. Local, state or federal laws may prohibit disposal of nickel-cadmium batteries in ordinary trash.

Consult your local waste authority for information regarding available recycling and/or disposal options.

WARNING:

Upon removal, cover the battery pack's terminals with heavy-duty adhesive tape. Do not attempt to destroy or disassemble battery pack or remove any of its components. Nickel-cadmium batteries must be recycled or disposed of properly. Also, never touch both terminals with metal objects and/or body parts as short circuit may result. Keep away from children. Failure to comply with these warnings could result in fire and/or serious injury.

ACCESSORIES

The following recommended accessories are currently available at retail stores:

- 5-1/2 in. Thin Kerf Blade

WARNING:

Current attachments and accessories available for use with this tool are listed above. Do not use any attachments or accessories not recommended by the manufacturer of this tool. The use of attachments or accessories not recommended can result in serious personal injury.

