

**RYOBI**  
**OSCILLATING SPINDLE SANDER**  
**MODEL NO. OSS500**  
**REPAIR SHEET**

# RYOBI OSCILLATING SPINDLE SANDER – MODEL NUMBER OSS500

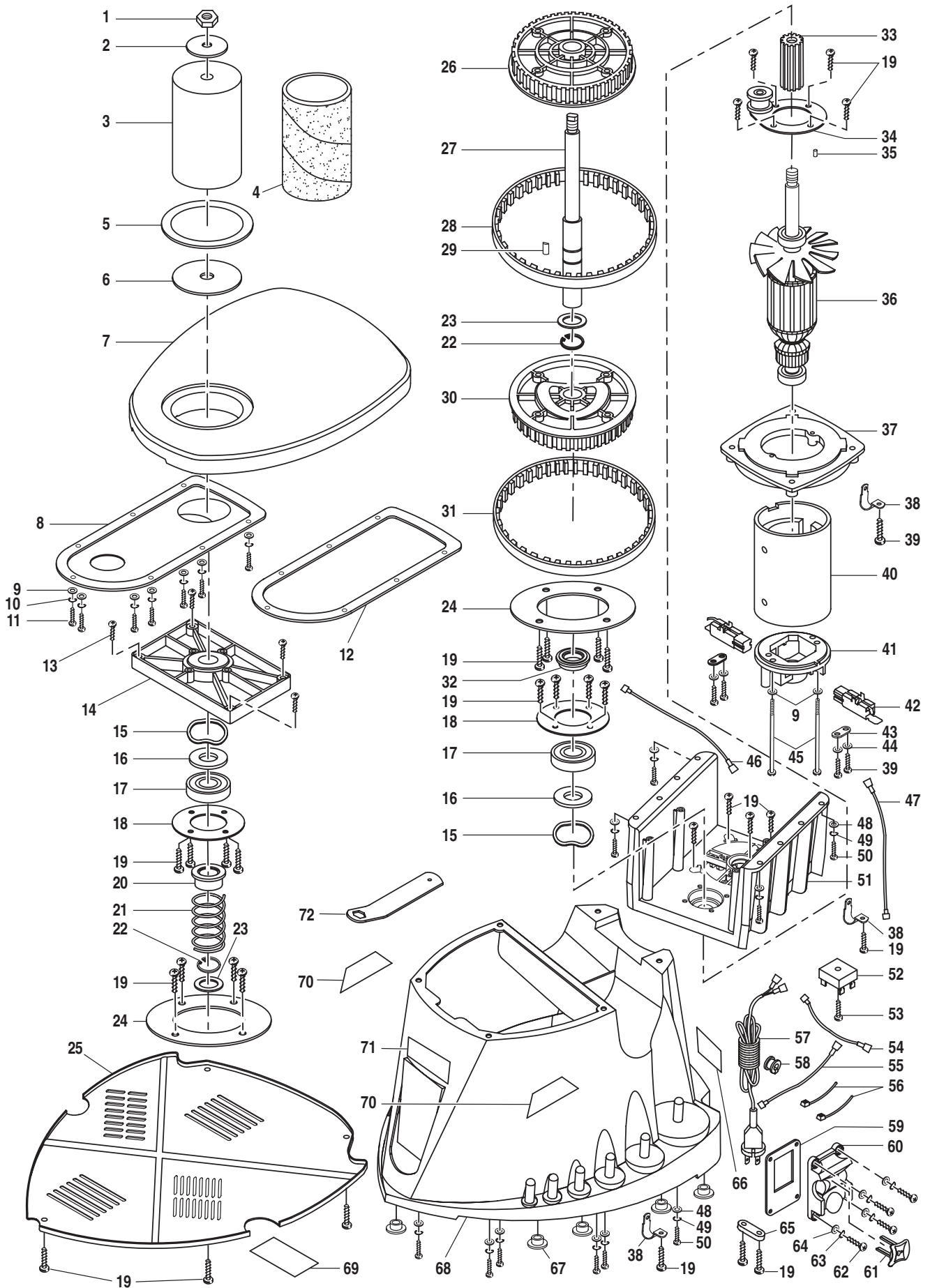

## RYOBI OSCILLATING SPINDLE SANDER – MODEL NUMBER OSS500

The model number will be found on a plate attached to the motor housing. Always mention the model number in all correspondence regarding your **OSCILLATING SANDER** or when ordering repair parts.

### PARTS LIST

KEY NO.	PART NUMBER	DESCRIPTION	QTY.	KEY NO.	PART NUMBER	DESCRIPTION	QTY.
1	OSS500-01	HEX NUT (M10) .....	1	38	OSS500-39	CABLE CLAMP .....	3
2	OSS500-02	UPPER SPINDLE WASHER (16.9 mm, 22.2 mm, 46 mm) .....	3	39	OSS500-38	SCREW (M4.2 X 13 mm) .....	5
3	OSS500-03	RUBBER SPINDLE (0.75 in., 1 in., 1.5 in., 2 in., 3 in.) .....	5	40	OSS500-37	FIELD ASSEMBLY .....	1
4	OSS500-04	SANDER SLEEVE (0.5 in., 0.75 in., 1 in., 1.5 in., 2 in., 3 in.) .....	18	41	OSS500-74	BRUSH HOLDER .....	1
5	OSS500-05	THROAT PLATE (0.5 in., 0.75 in., 1 in., 1.5 in., 2 in., 3 in.) .....	6	42	OSS500-68	BRUSH ASSEMBLY .....	2
6	OSS500-06	LOWER SPINDLE WASHER .....	1	43	OSS500-64	CLAMP .....	2
7	OSS500-07	CAST IRON TABLE .....	1	44	OSS500-65	WASHER .....	4
8	OSS500-08	DUST COVER .....	1	45	OSS500-66	SCREW .....	2
9	OSS500-09	WASHER (M5) .....	9	46	OSS500-67	WIRE ASSEMBLY .....	1
10	OSS500-10	SPRING WASHER (M5) .....	7	47	OSS500-70	WIRE ASSEMBLY .....	1
11	OSS500-11	SCREW (M5 X 20 mm) .....	7	48	OSS500-41	WASHER (M6) .....	10
12	OSS500-12	RUBBER SEAL .....	1	49	OSS500-42	SPRING WASHER (M6) .....	10
13	OSS500-13	SCREW (M4.2 X 19 mm) .....	4	50	OSS500-43	SCREW (M6 X 20 mm) .....	10
14	OSS500-14	BEARING SUPPORT .....	1	51	OSS500-69	PULLEY SUPPORT .....	1
15	OSS500-15	RUBBER WASHER .....	2	52	OSS500-71	RECTIFIER .....	1
16	OSS500-16	DUST WASHER .....	2	53	OSS500-72	SCREW (M4.2 X 19 mm) .....	1
17	OSS500-17	BALL BEARING (6203) .....	2	54	OSS500-47	WIRE ASSEMBLY .....	1
18	OSS500-18	BEARING PLATE .....	2	55	OSS500-48	WIRE ASSEMBLY .....	1
19	OSS500-19	SCREW (M4.2 X 6 mm) .....	31	56	OSS500-49	WIRE TIE .....	3
20	OSS500-20	SLEEVE .....	1	57	OSS500-46	POWER CORD W/PLUG .....	1
21	OSS500-21	SPRING .....	1	58	OSS500-45	STRAIN RELIEF .....	1
22	OSS500-22	RETAINING WASHER .....	2	59	OSS500-50	SWITCH PLATE .....	1
23	OSS500-23	WASHER .....	2	60	984406-001	SWITCH ASSEMBLY .....	1
24	OSS500-24	BELT GUIDE PLATE .....	2	61	984406-003	SWITCH KEY .....	1
25	OSS500-25	BOTTOM COVER .....	1	62	OSS500-52	SCREW (M4 X 16 mm) .....	4
26	OSS500-26	FIXED PULLEY .....	1	63	OSS500-53	SPRING WASHER (M4) .....	4
27	OSS500-27	SHAFT .....	1	64	OSS500-54	WASHER (M4) .....	4
28	OSS500-28	WIDE TIMING BELT .....	1	65	OSS500-55	CORD CLAMP .....	1
29	OSS500-29	HI-PRO KEY .....	1	66	OSS500-56	DATA PLATE .....	1
30	OSS500-30	FLOATING PULLEY .....	1	67	OSS500-57	CUSHION .....	5
31	OSS500-31	NARROW TIMING BELT .....	1	68	OSS500-44	CABINET .....	1
32	OSS500-32	SLEEVE .....	1	69	OSS500-60	WARNING LABEL .....	2
33	OSS500-63	TIMING PULLEY .....	1	70	OSS500-58	WARNING LABEL .....	2
34	OSS500-62	IDLER & TENSION ROLLER ASM. ....	1	71	OSS500-59	LOGO PLATE .....	1
35	623019-004	RUBBER PLUG .....	1	72	OSS500-40	WRENCH .....	1
36	OSS500-36	ARMATURE ASSEMBLY .....	1		OSS500-35	MOTOR ASSEMBLY (NOT SHOWN) (INCL. KEY NOS. 19, 33, 35, 36, 37, 40-47, 51-53) .....	1
37	OSS500-73	MOTOR MOUNTING PLATE .....	1		983000-146R 5-03	OPERATOR'S MANUAL	

**WARNING:** Improper repair of a double insulated tool can result in damage to the double insulation system possibly causing electrical shock or electrocution. Any repairs requiring disassembly of your tool requires safety testing and should only be performed by a Ryobi Authorized Service Center. For the service center nearest you call 1-800-525-2579.

\* Standard Hardware Item – May Be Purchased Locally