

RYOBI
JIG SAW
MODEL NO. JS550
REPAIR SHEET

RYOBI JIG SAW – MODEL NUMBER JS550

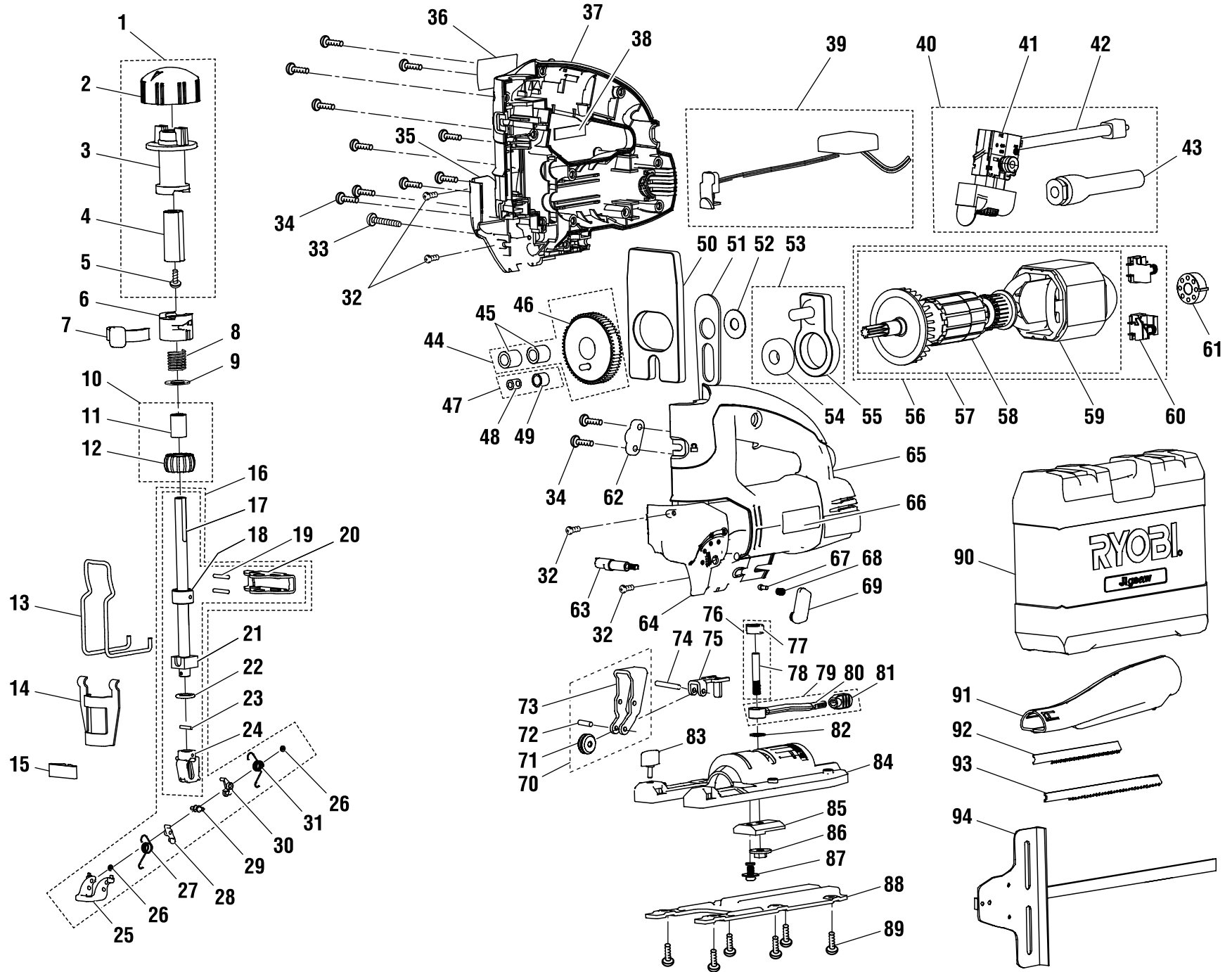

RYOBI JIG SAW – MODEL NUMBER JS550

The model number will be found on a plate attached to the motor housing. Always mention the model number in all correspondence regarding your **JIG SAW** or when ordering repair parts.

PARTS LIST

Key Part No. Number	Description	Qty.	Key Part No. Number	Description	Qty.		
1	300187005	SCROLLING ASSEMBLY	1	25	511826001	BLADE CLAMP LEVER	1
2	511772001	SCROLLING COVER.....	1	26	671319001	* E-RING (2.0 mm X 4 mm X 0.4 mm)	2
3	511770001	SCROLLING	1	27	690387001	COIL SPRING.....	1
4	671142001	SAW BAR GUIDE BUSHING.....	1	28	690377003	RIGHT LINKAGE ARM	1
5	660206014	* SCREW (M3.5 x 14 mm)	1	29	671318001	ROLLER	1
6	511773001	SCROLLING RELEASE KNOB	1	30	690377004	LEFT LINKAGE ARM.....	1
7	301011001	SCROLLING RELEASE KNOB ASSEMBLY	1	31	690387002	COIL SPRING.....	1
8	671146001	* SPRING (13.5 mm X 1.25 mm X 18 mm)	1	32	660182006	* SCREW (#6 X 12 mm)	4
9	550427001	WASHER	1	33	660165003	* SCREW (M4 X 18 mm)	1
10	300306015	HEAT SINK ASSEMBLY	1	34	660208005	* SCREW (M4 X 16 mm)	12
11	680974001	SLEEVE BEARING	1	35	640788001	RIGHT FRONT COVER	1
12	640492001	HEAT SINK	1	36	TBA	DATA LABEL	1
13	671147001	GUARD WIRE.....	1	37	511768001	HOUSING COVER.....	1
14	630845001	SLIDE GUIDE PLATE.....	1	38	940140031	LABEL SENSORMATIC TAG	1
15	631252001	SPRING PLATE	1	39	280010091	PCB ASSEMBLY	1
16	301007001	SAW BAR AND BLADE CLAMP ASSEMBLY	1	40	270017006	SWITCH ASSEMBLY	1
17	671152001	SAW BAR	1	41	760342001	SWITCH	1
18	671153001	CROSS SLIDE COLLAR.....	1	42	730377003	POWER CORD	1
19	690072002	SPRING PIN	2	43	590274004	STRAIN RELIEF.....	1
20	631085001	SAW BAR SLIDE BRACKET.....	1	44	220016096	GEAR BOX ASSEMBLY	1
21	671038001	BEARING SLEEVE	1	45	680911001	NEEDLE BEARING.....	2
22	550427001	WASHER	1	46	610388001	OUTPUT GEAR	1
23	680839002	NEEDLE ROLLER.....	1	47	300019002	BUSHING ASSEMBLY W/BEARING	1
24	640789001	CLAMP HOUSING	1	48	680901001	NEEDLE BEARING.....	1

WARNING: Improper repair of a double insulated tool can result in damage to the double insulation system possibly causing electrical shock or electrocution. Any repairs requiring disassembly of your tool requires safety testing and should only be performed by a Ryobi Authorized Service Center. For the service center nearest you call 1-800-525-2579.

* Standard Hardware Item – May Be Purchased Locally

RYOBI JIG SAW – MODEL NUMBER JS550

The model number will be found on a plate attached to the motor housing. Always mention the model number in all correspondence regarding your **JIG SAW** or when ordering repair parts.

PARTS LIST

Key Part No. Number	Description	Qty.	Key Part No. Number	Description	Qty.
49	680900001 BUSHING	1	73	631084001 BLADE GUIDE HOLDER	1
50	671008001 BALANCE BLOCK.....	1	74	671143001 * PIN (3.15 mm X 23 mm)	1
51	631081001 DRIVE PLATE	1	75	631082001 LINK ROD.....	1
52	630844001 WASHER	1	76	301008001 FIX WEDGE ASSEMBLY	1
53	300926004 BEARING PLATE ASSEMBLY	1	77	671151001 FIX WEDGE	1
54	680070002 BALL BEARING (26 mm X 10 mm X 8 mm).....	1	78	620286001 SHAFT	1
55	671007001 BEARING PLATE	1	79	301010001 BASE TOOL-LESS LEVER ASSEMBLY	1
56	230110006 MOTOR ASSEMBLY	1	80	640785001 ROTARY WEDGE AND LEVER.....	1
57	290094088 FIELD AND ARMATURE ASSEMBLY	1	81	511776001 BASE TOOL LEVER SLEEVE	1
58	740589001 ARMATURE ASSEMBLY	1	82	678050001 * WASHER (11.2 mm X 5.2 mm X 0.8).....	1
59	740588001 FIELD ASSEMBLY.....	1	83	301124001 KNOB BOLT ASSEMBLY	1
60	290069044 CARBON BRUSH ASSEMBLY	2	84	640783001 BASE	1
61	680898001 BEARING.....	1	85	671150001 ADJUSTABLE PAD.....	1
62	590501001 CORD CLAMP.....	1	86	631083001 * FIX NUT (M5).....	1
63	671154001 ORBITAL ADJUSTABLE ROD	1	87	660176006 * SCREW (M4 X 8 mm)	1
64	640787001 LEFT FRONT COVER.....	1	88	631109001 BASE COVER.....	1
65	511769001 HOUSING SUPPORT	1	89	660213008 * SCREW (M4 X 10 mm)	6
66	TBA LOGO PLATE	1	90	300912051 CARRYING CASE	1
67	550424001 DETENT BUTTON	1	91	301009001 VACUUM ASSEMBLY	1
68	680909001 SPRING	1	92	671208001 METAL CUTTING BLADE (18-24 TPI)	1
69	511774001 ORBITAL KNOB	1	93	671207001 WOOD CUTTING BLADE (6-8 TPI)	1
70	300577015 BLADE GUIDE ASSEMBLY	1	94	631097001 EDGE GUIDE.....	1
71	671382001 BLADE GUIDE ROLLER.....	1		983000-475 OPERATOR'S MANUAL	
72	680836002 NEEDLE ROLLER.....	1		983000-475R REPAIR SHEET	
				4-26-04	

WARNING: Improper repair of a double insulated tool can result in damage to the double insulation system possibly causing electrical shock or electrocution. Any repairs requiring disassembly of your tool requires safety testing and should only be performed by a Ryobi Authorized Service Center. For the service center nearest you call 1-800-525-2579.

* Standard Hardware Item – May Be Purchased Locally