

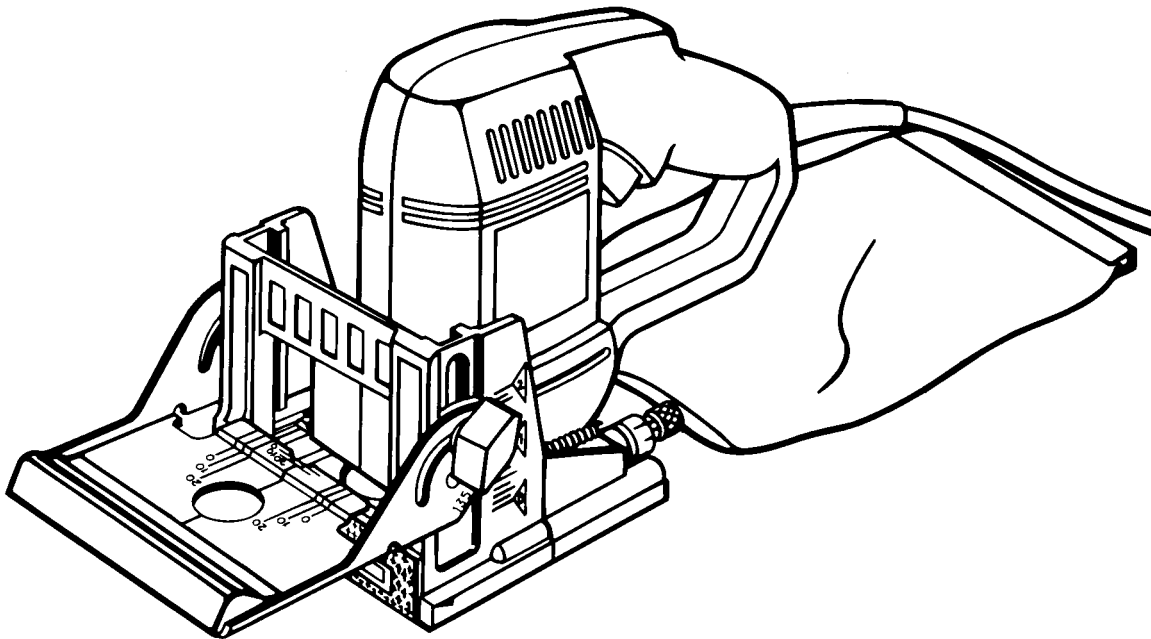

# OPERATOR'S MANUAL PLATE JOINER JM81-1 DOUBLE INSULATED



Your new tool has been engineered and manufactured to Ryobi's high standard for dependability, ease of operation, and operator safety. When properly cared for, it will give you years of rugged, trouble-free performance.

**⚠ WARNING:** To reduce the risk of injury, the user must read and understand the operator's manual before using this product.

Thank you for buying a Ryobi Product.

**SAVE THIS MANUAL FOR FUTURE REFERENCE**

# TABLE OF CONTENTS

■ Introduction .....	2
■ General Safety Rules .....	3-4
■ Specific Safety Rules .....	4
■ Symbols .....	5
■ Electrical .....	6
■ Features .....	7-8
■ Adjustments .....	9-10
■ Operation .....	11-16
■ Maintenance .....	17-19
■ Accessories .....	19
■ Troubleshooting .....	20
■ Service Information .....	22

## INTRODUCTION

Spline joinery is one of the strongest methods of joinery used in woodworking. When glue is properly applied to a spline and to the joint area of the wood pieces being connected, a large surface area receives the adhesion properties of the glue. This forms a very strong joint.

Traditional spline joinery requires cutting slots with a router or table saw. Small, thin strips of wood must then be cut to fit inside the slots and act as splines.

Newer methods of spline joinery use a plate or biscuit joiner to cut precise mating oval slots in adjoining boards. Your new plate joiner is a fast, simple, and accurate plunge cutting tool that can be used for this purpose. It can be used to cut slots in hardwood, softwood, plywood, particle board, and other pressed woods.

Football shaped wafers, called biscuits, are then placed inside the slots with glue and used to help line up adjoining surfaces. When a water based glue is used, the biscuits swell in the joint, making an extremely strong and firm bond. White glue, yellow glue, carpenters glue, hide glue, and aliphatic resin glue are examples of water based glues. This bonding technique has traditionally been limited to making edge-to-edge joints. However, with the use of your new plate joiner, biscuits can now be easily used to connect butt, miter, and T-joints. Biscuit joining can be as strong as mortise and tenon, tongue and groove, standard spline, and doweled joints. In most cases the material around the biscuit will break before the biscuit itself will break. A greater surface area is exposed to glue in a biscuit joint, making the seams stronger.



### WARNING:

Do not attempt to use this tool until you have read thoroughly and understand completely the operator's manual. Pay close attention to the safety rules, including Dangers, Warnings, and Cautions. If you use this tool properly and only for what it is intended, you will enjoy years of safe, reliable service.



**Look for this symbol to point out important safety precautions. It means attention!!! Your safety is involved.**



### WARNING:



The operation of any tool can result in foreign objects being thrown into your eyes, which can result in severe eye damage. Before beginning operation, always wear safety goggles or safety glasses with side shields and a full face shield when needed. We recommend Wide Vision Safety Mask for use over eyeglasses or standard safety glasses with side shields. Always wear eye protection which is marked to comply with ANSI Z87.1.

# GENERAL SAFETY RULES

## WARNING:

Read and understand all instructions. Failure to follow all instructions listed below, may result in electric shock, fire and/or serious personal injury.

## SAVE THESE INSTRUCTIONS

### WORK AREA

- **Keep your work area clean and well lit.** Cluttered benches and dark areas invite accidents.
- **Do not operate power tools in explosive atmospheres, such as in the presence of flammable liquids, gases, or dust.** Power tools create sparks which may ignite the dust or fumes.
- **Keep bystanders, children, and visitors away while operating a power tool.** Distractions can cause you to lose control.

### ELECTRICAL SAFETY

- **Double insulated tools are equipped with a polarized plug (one blade is wider than the other). This plug will fit in a polarized outlet only one way. If the plug does not fit fully in the outlet, reverse the plug. If it still does not fit, contact a qualified electrician to install a polarized outlet. Do not change the plug in any way.** Double insulation  eliminates the need for the three-wire grounded power cord and grounded power supply system.
- **Avoid body contact with grounded surfaces such as pipes, radiators, ranges, and refrigerators.** There is an increased risk of electric shock if your body is grounded.
- **Don't expose power tools to rain or wet conditions.** Water entering a power tool will increase the risk of electric shock.
- **Do not abuse the cord. Never use the cord to carry the tools or pull the plug from an outlet. Keep cord away from heat, oil, sharp edges, or moving parts. Replace damaged cords immediately.** Damaged cords increase the risk of electric shock.
- **When operating a power tool outside, use an outdoor extension cord marked "W-A" or "W".** These cords are rated for outdoor use and reduce the risk of electric shock.

### PERSONAL SAFETY

- **Stay alert, watch what you are doing and use common sense when operating a power tool. Do not use tool while tired or under the influence of drugs, alcohol, or medication.** A moment of inattention while operating power tools may result in serious personal injury.
- **Dress properly. Do not wear loose clothing or jewelry. Contain long hair. Keep your hair, clothing, and gloves away from moving parts.** Loose clothes, jewelry, or long hair can be caught in moving parts.
- **Avoid accidental starting. Be sure switch is off before plugging in.** Carrying tools with your finger on the

switch or plugging in tools that have the switch on invites accidents.

- **Remove adjusting keys or wrenches before turning the tool on.** A wrench or a key that is left attached to a rotating part of the tool may result in personal injury.
- **Do not overreach. Keep proper footing and balance at all times.** Proper footing and balance enables better control of the tool in unexpected situations.
- **Use safety equipment. Always wear eye protection.** Dust mask, nonskid safety shoes, hard hat, or hearing protection must be used for appropriate conditions.
- **Do not wear loose clothing or jewelry. Contain long hair.** Loose clothes, jewelry, or long hair can be drawn into air vents.
- **Do not use on a ladder or unstable support.** Stable footing on a solid surface enables better control of the tool in unexpected situations.

### TOOL USE AND CARE

- **Use clamps or other practical way to secure and support the workpiece to a stable platform.** Holding the work by hand or against your body is unstable and may lead to loss of control.
- **Do not force tool. Use the correct tool for your application.** The correct tool will do the job better and safer at the rate for which it is designed.
- **Do not use tool if switch does not turn it on or off.** Any tool that cannot be controlled with the switch is dangerous and must be repaired.
- **Disconnect the plug from power source before making any adjustments, changing accessories, or storing the tool.** Such preventive safety measures reduce the risk of starting the tool accidentally.
- **Store idle tools out of the reach of children and other untrained persons.** Tools are dangerous in the hands of untrained users.
- **Maintain tools with care. Keep cutting tools sharp and clean.** Properly maintained tools with sharp cutting edges are less likely to bind and are easier to control.
- **Check for misalignment or binding of moving parts, breakage of parts, and any other condition that may affect the tool's operation. If damaged, have the tool serviced before using.** Many accidents are caused by poorly maintained tools.
- **Use only accessories that are recommended by the manufacturer for your model.** Accessories that may be suitable for one tool, may become hazardous when used on another tool.
- **Keep the tool and its handle dry, clean and free from oil and grease.** Always use a clean cloth when cleaning. Never use brake fluids, gasoline, petroleum-based products, or any strong solvents to clean your tool. Following this rule will reduce the risk of loss of control and deterioration of the enclosure plastic.

# GENERAL SAFETY RULES

## SERVICE

- **Tool service must be performed only by qualified repair personnel.** Service or maintenance performed by unqualified personnel may result in a risk of injury.
- **When servicing a tool, use only identical replacement parts. Follow instructions in the Maintenance section of this manual.** Use of unauthorized parts or failure to follow Maintenance Instructions may create a risk of shock or injury.

# SPECIFIC SAFETY RULES

- **Hold tool by insulated gripping surfaces when performing an operation where the cutting tool may contact hidden wiring or its own cord.** Contact with a “live” wire will make exposed metal parts of the cutting tool “live” and shock the operator.

## ADDITIONAL SAFETY RULES

- **Know your power tool. Read operator’s manual carefully. Learn its applications and limitations, as well as the specific potential hazards related to this tool.** Following this rule will reduce the risk of electric shock, fire, or serious injury.
- **Always wear safety glasses. Everyday eyeglasses have only impact-resistant lenses; they are NOT safety glasses.** Following this rule will reduce the risk of serious personal injury.
- **Protect your lungs. Wear a face or dust mask if the operation is dusty.** Following this rule will reduce the risk of serious personal injury.
- **Protect your hearing. Wear hearing protection during extended periods of operation.** Following this rule will reduce the risk of serious personal injury.
- **Inspect tool cords periodically and, if damaged, have repaired at your nearest Authorized Service Center. Constantly stay aware of cord location.** Following this rule will reduce the risk of electric shock or fire.
- **Check damaged parts. Before further use of the tool, a guard or other part that is damaged should be carefully checked to determine that it will operate properly and perform its intended function. Check for alignment of moving parts, binding of moving parts, breakage of parts, mounting, and any other conditions that may affect its operation. A guard or other part that is damaged should be properly repaired or replaced by an authorized service center.** Following this rule will reduce the risk of shock, fire, or serious injury.
- **Do not abuse cord. Never carry the tool by the cord or yank it to disconnect it from the receptacle. Keep cord away from heat, oil, and sharp edges.** Following this rule will reduce the risk of electric shock or fire.
- **Make sure your extension cord is in good condition. When using an extension cord, be sure to use one heavy enough to carry the current your product will draw. A wire gage size (A.W.G.) of at least 14 is recommended for an extension cord 50 feet or less in length. A cord exceeding 100 feet is not recommended. If in doubt, use the next heavier gage. The smaller the gage number, the heavier the cord.** An undersized cord will cause a drop in line voltage resulting in loss of power and overheating.
- **Inspect for and remove all nails from lumber before using this tool.** Following this rule will reduce the risk of serious personal injury.
- **Drugs, alcohol, medication. Do not operate tool while under the influence of drugs, alcohol, or any medication.** Following this rule will reduce the risk of electric shock, fire, or serious personal injury.
- **Save these instructions.** Refer to them frequently and use them to instruct others who may use this tool. If you loan someone this tool, loan them these instructions also.

### **WARNING:**

Some dust created by power sanding, sawing, grinding, drilling, and other construction activities contains chemicals known to cause cancer, birth defects or other reproductive harm. Some examples of these chemicals are:





- lead from lead-based paints,
- crystalline silica from bricks and cement and other masonry products, and
- arsenic and chromium from chemically-treated lumber.

Your risk from these exposures varies, depending on how often you do this type of work. To reduce your exposure to these chemicals: work in a well ventilated area, and work with approved safety equipment, such as those dust masks that are specially designed to filter out microscopic particles.

## SAVE THESE INSTRUCTIONS

# SYMBOLS

**Important:** Some of the following symbols may be used on this tool. Please study them and learn their meaning. Proper interpretation of these symbols will allow you to operate the tool better and safer.

SYMBOL	NAME	DESIGNATION/EXPLANATION
V	Volts	Voltage
A	Amperes	Current
Hz	Hertz	Frequency (cycles per second)
W	Watt	Power
min	Minutes	Time
~	Alternating Current	Type of current
≡	Direct Current	Type or a characteristic of current
no	No Load Speed	Rotational speed, at no load
	Class II Construction	Double-insulated construction
.../min	Per Minute	Revolutions, strokes, surface speed, orbits etc., per minute
	Safety Alert	Precautions that involve your safety
	Read The Operator's Manual	To reduce the risk of injury, the user must read and understand the operator's manual before using this product.
	Eye Protection	Always wear safety goggles or safety glasses with side shields and a full face shield when operating this product.
	Wet Conditions Alert	Do not expose to rain or use in damp locations.

The purpose of safety symbols is to attract your attention to possible dangers. The safety symbols, and the explanations with them, deserve your careful attention and understanding. The safety warnings do not by themselves eliminate any danger. The instructions or warnings they give are not substitutes for proper accident prevention measures.



**DANGER:** Indicates an imminently hazardous situation, which, if not avoided, will result in death or serious injury.



**WARNING:** Indicates a potentially hazardous situation, which, if not avoided, could result in death or serious injury.



**CAUTION:** Indicates a potentially hazardous situation, which, if not avoided, may result in minor or moderate injury. It may also be used to alert against unsafe practices that may cause property damage.

**Note:**

Advises you of additional information concerning the operation or maintenance of the equipment.

# ELECTRICAL

## DOUBLE INSULATION

Your Ryobi power tool is double insulated. This means you are separated from the tool's electrical system by two complete sets of electrical insulation. This extra layer of insulation is intended to protect the user from electrical shock due to a break in the wiring insulation. All exposed metal parts are isolated from the internal metal motor components with protecting insulation. Double insulated tools do not need to be grounded.

**Important: Servicing of a tool with double insulation requires extreme care and knowledge of the system and should be performed only by a qualified technician. For service, we suggest you return the tool to your nearest authorized service center for repair. When servicing, use original factory replacement parts .**



### WARNING:

The double insulated system is intended to protect the user from shock resulting from a break in the tool's internal wiring. Observe all normal safety precautions related to avoiding electrical shock.

## ELECTRICAL CONNECTION

This tool has a precision-built electric motor. It should be connected to a power supply that is 120 volts, 60 HZ, AC only (normal household current). Do not operate this tool on direct current (DC). A substantial voltage drop will cause a loss of power and the motor will overheat. If our tool does not operate when plugged into an outlet, double-check the power supply.

## EXTENSION CORDS

When using a power tool at a considerable distance from a power source, be sure to use an extension cord that has the capacity to handle the current the tool will draw. An undersized cord will cause a drop in line voltage, resulting in overheating and loss of power. Use the chart to determine the minimum wire size required in an extension cord. Only round jacketed cords should be used.

When working with a tool outdoors, use an extension cord that is designed for outside use. This is indicated by the letters "WA" on the cord's jacket.

Before using any extension cord, inspect it for loose or exposed wires and cut or worn insulation.

\*\*Ampere rating

(on tool faceplate) 0-2.0 2.1-3.4 3.5-5.0 5.1-7.0 7.1-12.0 12.1-16.0

Cord Length	Wire Size (A.W.G.)					
25'	16	16	16	16	14	14
50'	16	16	16	14	14	12
100'	16	16	14	12	10	—

\*\*Used on 12 gauge - 20 amp circuit.



### WARNING:

Keep the extension cord clear of the working area. Position the cord so that it will not become entangled in the rotating foam pad or caught on lumber, tools or other obstructions while you are working with a power tool. Failure to do so can result in serious personal injury.



### WARNING:

Check extension cords before each use. If damaged, replace immediately. Never use tool with a damaged cord since touching the damaged area could cause electrical shock resulting in serious injury.

# FEATURES

## SPECIFICATIONS

No Load Speed .....	10,000 rpm
Rating .....	120 volts, 60 HZ, AC, 6.0 Amperes
Fence Angle Adjustment With 45° Positive Stops .....	0 - 135°
Depth Of Cut With Micro Depth Of Cut Adjustment .....	0 - 5/8 in. (16mm)
Net Weight .....	6.8 lb. (3.1 kg)

Your Plate Joiner has been designed for making fast, accurate, and simple plunge cuts in wood, etc. so that biscuits can be used to join two or more boards together. When used properly and only for what it is intended, this versatile tool will give you years of trouble-free performance. It is professionally engineered, but its ease of operation allows the amateur to produce work that is beautiful and precise.

## SWITCH

To turn your plate joiner **ON**, depress the switch trigger. Release switch trigger to turn your plate joiner **OFF**.

## MOTOR

Your plate joiner has a powerful motor with sufficient power to handle tough cutting jobs. It develops a no load speed of 10,000 RPM.

## CARBIDE TIPPED BLADE

Your plate joiner has an 8-tooth carbide-tipped blade for cutting biscuit slots.

## NON-SKID BACKING PAD

The fence on your plate joiner is padded with a non-skid backing pad to hold it stationary against the workpiece. It helps prevent skidding when making cuts. It also prevents marring of the workpiece from your plate joiner when making cuts.

## APPLICATIONS

(Use only for the purpose listed below)

- Cutting precise mating oval slots in hard wood, soft wood, plywood, particle board, etc., for spline joinery applications.

## ELECTRICAL CONNECTION

Your tool has a precision built electric motor. **It should be connected to a power supply that is 120 volts, 60 HZ, AC only (normal household current.)** A substantial voltage drop will cause a loss of power and overheating. If your tool does not operate when plugged into an outlet, double-check the power supply.

## DEPTH ADJUSTMENT KNOB

A spring loaded depth adjustment knob makes it possible to make proper settings for three standard size biscuits. Fine adjustments to the cutting depth can be made with a knurled adjustment knob and jam nut located behind the depth adjustment knob. Once the correct depth setting has been made for one biscuit size, the other two depth settings will be automatically set.

## DUSTLESS FEATURE

The dust bag provides a dust collection system. Wood particles are drawn up through a tunnel in the base and collect in the dust bag during cutting operations.

## INDICATOR MARKS

Centerline and line of cut indicator marks have been provided on your plate joiner. See Figure 2.

## BISCUITS

See Figure 1.

Biscuits are available in three standard sizes:

**#0 (5/8 in. x 1-13/16 in.)**

**#10 (13/16 in. x 2-1/16 in.)**

**#20 (15/16 in. x 2-5/16 in.)**

**NOTE:** Biscuits swell rapidly upon contact with water-based woodworking glues.

## ADJUSTABLE FENCE / FRONT HANDLE

Your plate joiner has an adjustable fence. By loosening the height adjustment knobs, the angle of the fence can be set at angles from 0° to 135°, with positive stop settings in increments of 45°. The height of the fence can be set between 0 in. - 2 in. with a scale showing 0 in. - 1-1/2 in.

The front handle is part of the adjustable fence and should always be used to guide and balance your plate joiner, providing ease of operation and maintaining safe control.

# FEATURES

#0 = 5/8 IN. X 1-13/16 IN.

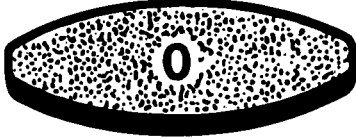

#10 = 13/16 IN. X 2-1/16 IN.

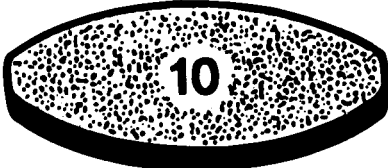

#20 = 15/16 IN. X 2-5/16 IN.

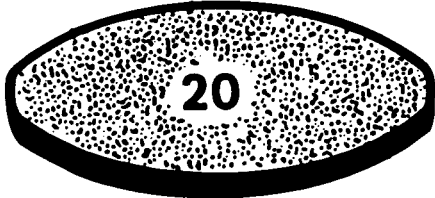

Fig. 1

## KNOW YOUR PLATE JOINER

See Figure 2.

Except for the dust bag, your plate joiner has been shipped completely assembled and ready for use. An operator's manual and warranty registration are also included. Inspect your new plate joiner carefully to make sure no breakage or damage has occurred during shipping. If any parts are damaged or missing, contact your local Ryobi factory or authorized service center to obtain replacement parts before attempting to operate your plate joiner.

The dust bag is easily installed on the rear of your tool. Its use will help keep the work area clean. Install dust bag by inserting the dust bag adaptor inside the blower exhaust on your plate joiner. For most efficient pick-up of wood particles, empty dust bag often.

Before attempting to use any tool familiarize yourself with all operating features and safety requirements.

### ⚠ WARNING:

Do not attempt to modify this tool or create accessories not recommended for use with this tool. Any such alteration or modification is misuse and could result in a hazardous condition leading to possible serious personal injury.

### ⚠ WARNING:

Do not allow familiarity with tools to make you careless. Remember that a careless fraction of a second is sufficient to inflict severe injury.

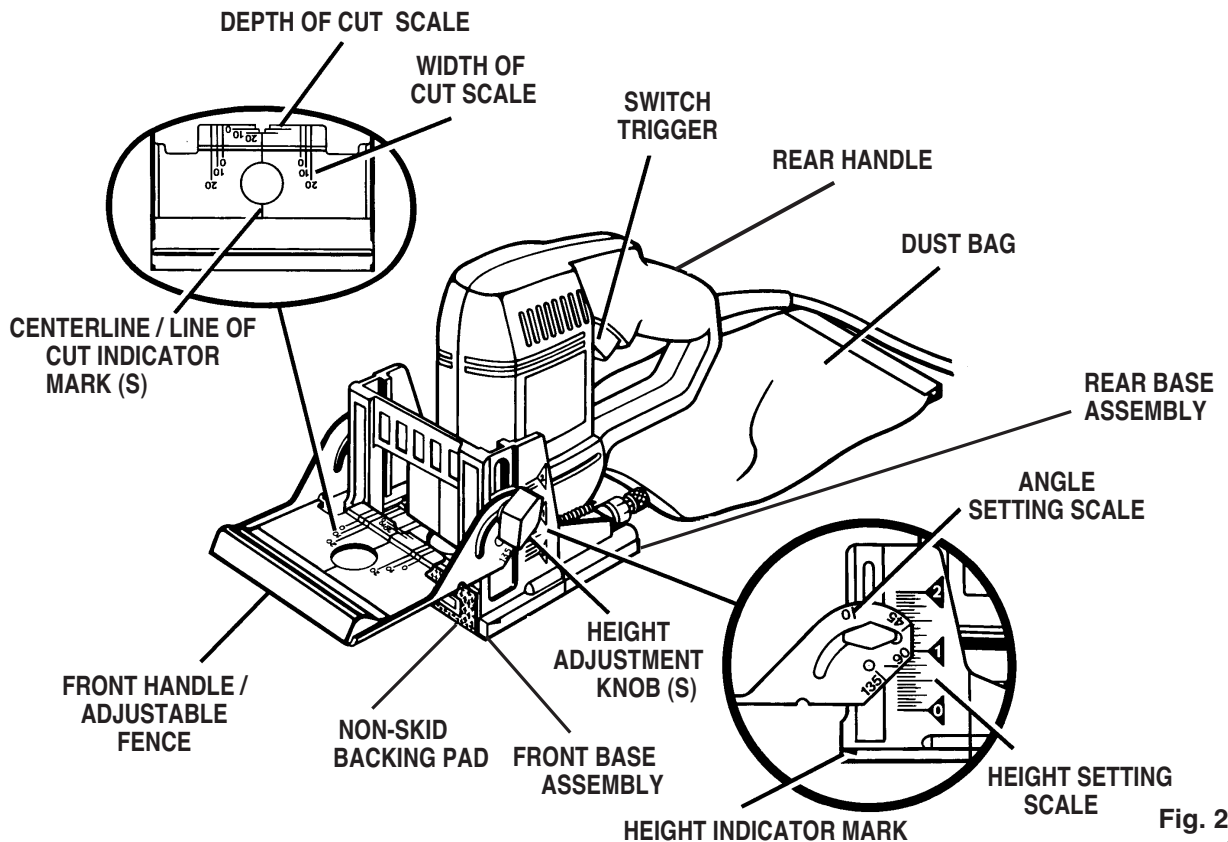

Fig. 2



# ADJUSTMENTS

## **⚠ WARNING:**

If any parts are missing, do not operate tool until the missing parts are replaced. Failure to do so could result in possible serious personal injury.

## DEPTH OF CUT ADJUSTMENTS

Your plate joiner can be adjusted to three standard cutting depths to accommodate three standard size biscuits — #0, #10, and #20. Adjustments are made by engaging slots on depth adjustment knob with tabs on rear base assembly. For example, when using a #0 size biscuit, rotate the depth adjustment knob to the slot marked 0. When using a #10 size biscuit, rotate the depth adjustment knob to the slot marked 10, and when using a #20 size biscuit rotate the depth adjustment knob to the slot marked 20. See Figure 3.

## TO SET DEPTH ADJUSTMENT KNOB

- Unplug your plate joiner.

## **⚠ WARNING:**

Failure to unplug your plate joiner could result in accidental starting causing possible serious personal injury.

- Pull knurled adjustment knob and jam nut in the direction of the arrow shown in figure 3.

**NOTE:** Knob and jam nut are spring loaded, therefore pulling them in the direction of the arrow shown puts pressure on the spring and releases pressure from the depth adjustment knob.

- Rotate depth adjustment knob until desired slot setting aligns with tabs on rear base assembly — 0, 10, or 20.
- Next release knurled adjustment knob and jam nut applying pressure from spring on depth adjustment knob.

Make a test cut in a scrap piece of wood. Fit the correct size biscuit into biscuit slot. If biscuit slot is too deep or too shallow, fine adjustments to the depth setting can be made by loosening knurled adjustment knob and making fine adjustments with the jam nut. Turning jam nut forward will cut shallow biscuit slots. Turning jam nut backwards will cut deeper biscuit slots. The biscuit slot should be deep enough to allow slightly more than one-half of the biscuit into the slot. This extra room allows for proper alignment of the wood being joined.

## TO MAKE FINE ADJUSTMENTS

See Figure 4.

- Unplug your plate joiner.
- Loosen knurled adjustment knob. This knob is used as a lock nut only. Loosen by twisting it in the opposite direction away from jam nut.

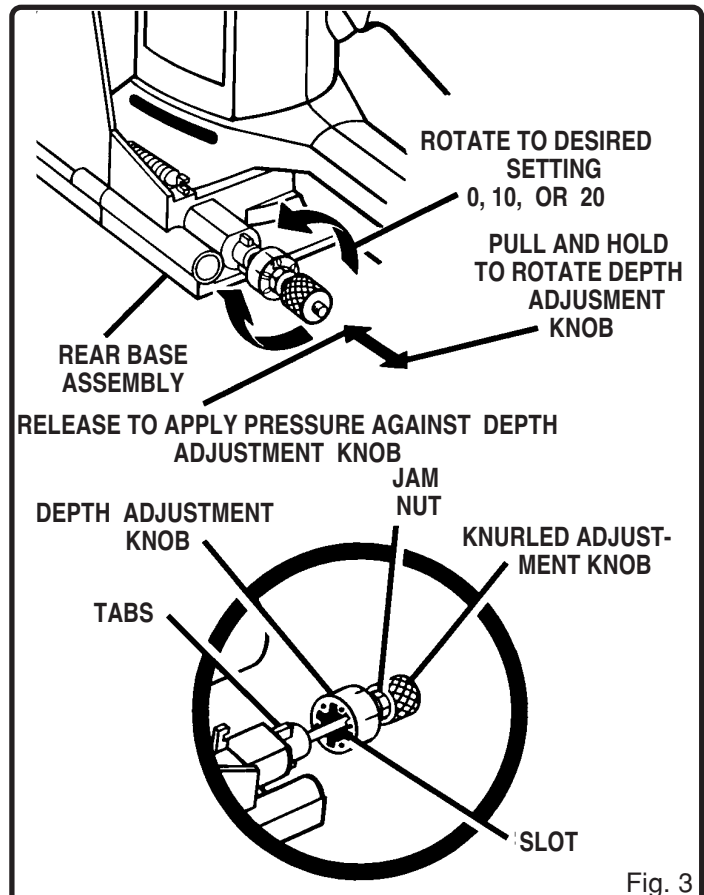

Fig. 3

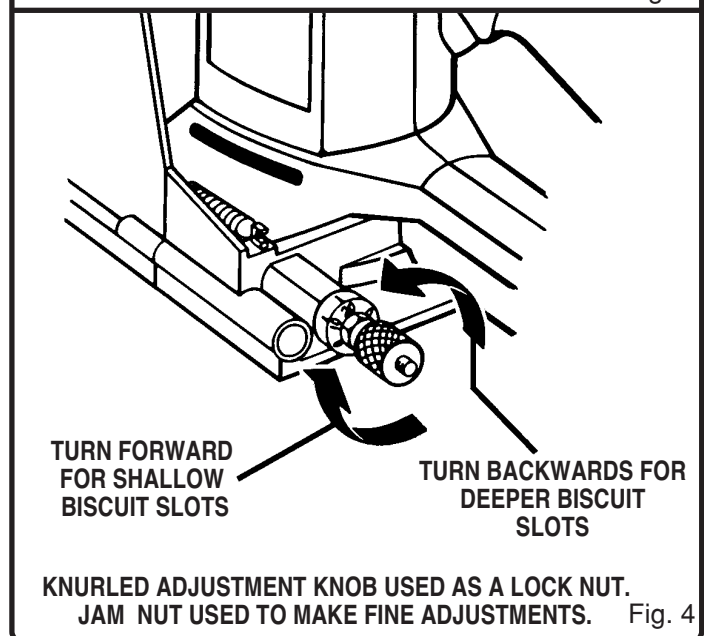

Fig. 4

- Turn jam nut forward for a more shallow cut, or backwards for a deeper cut.
- Once desired depth of cut is reached, hold jam nut so that it will not move out of adjustment. Next, tighten knurled adjustment knob against jam nut.
- Recheck depth setting by making a test cut in a scrap piece of wood. Also periodically check depth setting for accuracy. See Figure 4.

# ADJUSTMENTS

## FENCE HEIGHT ADJUSTMENT

See Figure 5.

The adjustable fence on your plate joiner can be moved up and down to adjust the position of the blade in relation to the top of the workpiece. A scale on both sides of the fence indicates the height of the fence from the center of the blade. The fence can be positioned up to two inches from the center of the blade. However, the scale and indicator point can only be set up to 1-1/2 in. from the center of the blade. Scale marks are in increments of 1/16 in.

### TO ADJUST HEIGHT SETTING

See Figure 5.

- Unplug your plate joiner.

#### **WARNING:**

Failure to unplug your plate joiner could result in accidental starting causing possible serious personal injury.

- Loosen the two height adjustment knobs.  
**NOTE:** Loosen each height adjustment knob approximately one turn.
- Slide the fence up or down until the indicator point is aligned with the desired dimension on the scale.
- Tighten height adjustment knobs securely.

## FENCE ANGLE ADJUSTMENT

See Figure 6.

The adjustable fence on your plate joiner can be set at angles ranging from 0° to 135°, with quick, accurate positive stops set in 45° increments. A scale is located on both sides of the front handle for identifying these positive stop angles. Each click you hear when rotating the adjustable fence from one angle setting to another equals a 45° positive stop angle change.

### TO ADJUST ANGLE SETTING

See Figure 6.

- Unplug your plate joiner.

#### **WARNING:**

Failure to unplug your plate joiner could result in accidental starting causing possible serious personal injury.

- Loosen the two height adjustment knobs.  
**NOTE:** Loosen each height adjustment knob approximately one turn.
- Rotate adjustable fence up or down to the desired angle.
- Tighten height adjustment knobs securely.

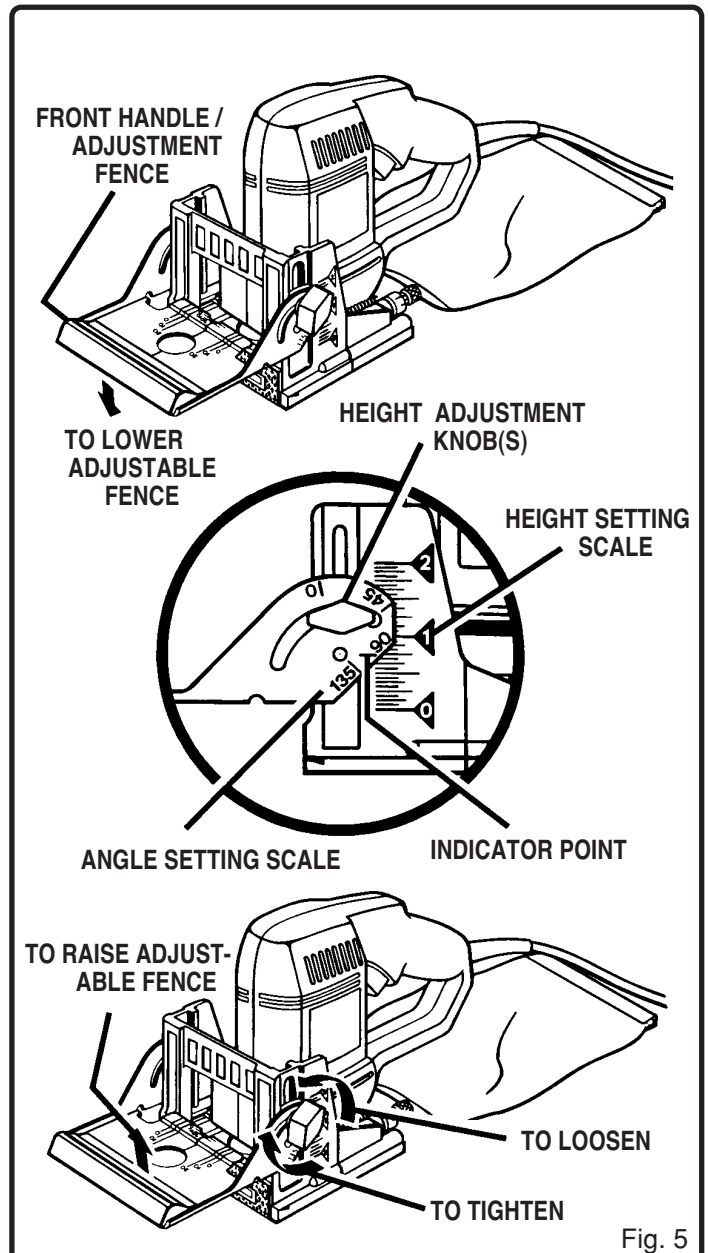

Fig. 5

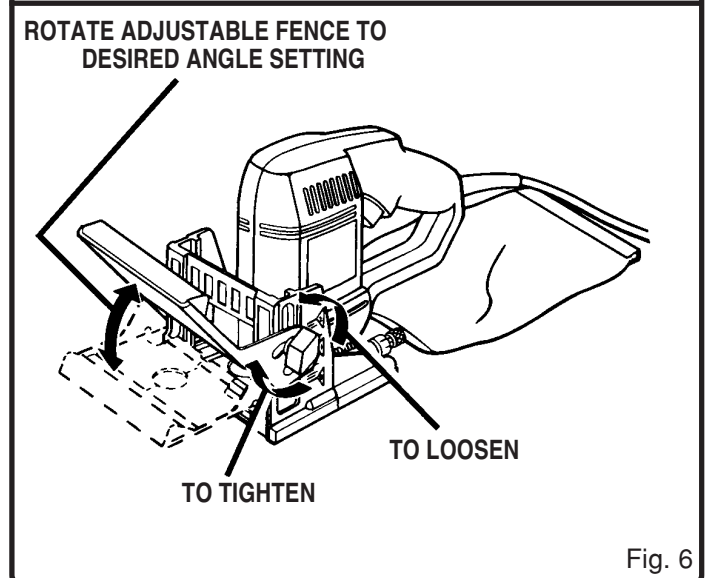

Fig. 6

# OPERATION

## **⚠ WARNING:**

Always wear safety goggles or safety glasses with side shields when operating tools. Failure to do so could result in objects being thrown into your eyes, resulting in possible serious injury.

A variety of spline joints can be made using your plate joiner. The number and size biscuits needed for each joint depends on the thickness of the wood and the length of the joint. In general, the small #0 biscuits should be used for miter cuts in 3/4 in. materials. The larger biscuits should be used for edge-to-edge joinery.

When joining 1-1/2 in. thick materials, stack two biscuits, one above the other. For example, joining 2 in. x 4 in. dressed lumber. See Figure 9. When joining even thicker materials, use additional biscuits, stacked above each other.

When making edge-to-edge joints for tabletops, workbenches, cutting boards, etc. the more biscuits you use, the stronger the joint will be.

The following sections illustrate how to make various spline joints using your plate joiner.

## **EDGE-TO-EDGE JOINTS**

See Figures 7 and 8.

Edge-to-edge joinery is one of the most basic and easiest joints to construct. In general, two basic adjustments have to be made for all biscuit joinery applications. One is the depth of cut and the other is the location of the cut.

## **HOW TO MAKE EDGE-TO-EDGE JOINTS**

- **Unplug your plate joiner.**
- Prepare the workpieces by laying them side by side on a workbench in the order in which they will be assembled.
- Using a square, determine the location of each biscuit spline joint and mark the center of each joint by drawing a line across each workpiece.  
**NOTE:** Mark the edges 2 in. from the ends of workpieces. The joint will be stronger if you use multiple biscuits placed close together.
- Loosen height adjustment knobs and set fence angle at 90°.
- Slide the fence up or down until the indicator point is aligned with the desired dimension on the scale.  
**REMEMBER:** The scale indicates the height of the fence from the center of the blade.
- Tighten height adjustment knobs securely.
- Select the correct depth of cut setting to match the biscuit size you are planning to use. We suggest that you make a test cut in a scrap piece of wood from the same workpiece if possible.
- Clamp workpiece securely so that it will not move during the cut.

- Plug your plate joiner into power supply and prepare to make your first cut. Grasp and hold your plate joiner securely with both hands by the front and rear handles as shown on page 3.
- Place the fence against the board and align the indicator marks on the fence with the centerline mark(s) on the board. See Figure 7.
- Depress the switch trigger to turn the power on your plate joiner, then push it forward to extend the blade into the wood.
- When the base assembly bottoms out against the depth of cut adjustment knob setting, pull back releasing pressure on the spring. Blade will retract from biscuit slot.
- Repeat this procedure for all desired biscuit slots.
- Once all biscuit slots have been cut, place a biscuit in each joint and dry assemble the workpieces. Make sure each joint lines up and fits.

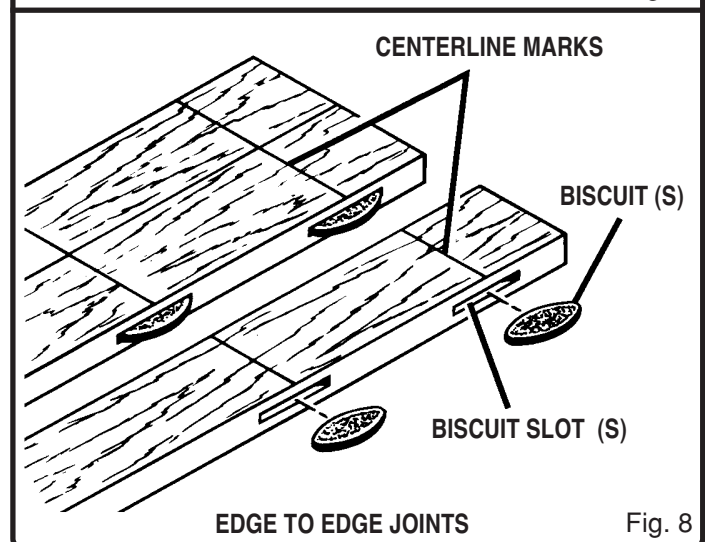
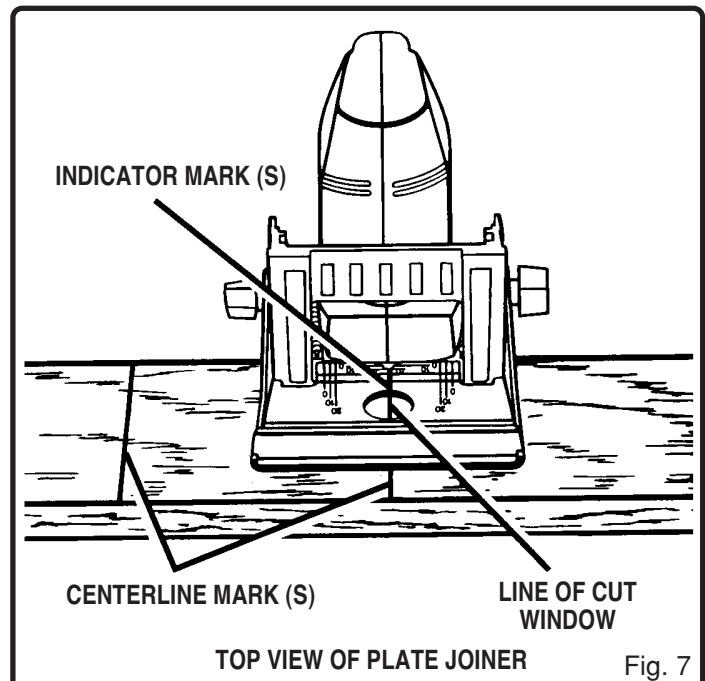

# OPERATION

- Finally, disassemble the workpieces and place a bead of glue in each slot. Also, spread a bead of glue over the entire surface of the joint. Reinsert the biscuits and assemble the workpieces. See Figure 8.
- Clamp workpieces together until the glue sets up.

## BUTT JOINTS

See Figure 9.

A butt joint is one of the weakest joints in woodworking. This type of joint is mating the end grain of one board with the edge grain of another. The bonding of glue on this type of surface is poor. However, by using biscuits you can create a very strong joint that gives a mortise-and-tenon effect.

## HOW TO MAKE BUTT JOINTS

- **Unplug your plate joiner.**
- Place the two pieces of wood to be joined on a level workbench. Align them against each other in the arrangement in which they will be assembled.
- Using a square, determine the location of each biscuit spline joint and mark the center of each joint by drawing a line across the edges of the two boards.
- Loosen height adjustment knobs and set fence angle at 90°.
- Slide the fence up or down until the indicator point is aligned with the desired dimension on the scale.
- **REMEMBER:** The scale indicates the height of the fence from the center of the blade.
- Tighten height adjustment knobs securely.
- Select the correct depth of cut setting to match the biscuit size you are planning to use. We suggest that you make a test cut in a scrap piece of wood from the same workpiece if possible.
- Clamp workpiece securely so that it will not move during the cut.
- Plug your plate joiner into power supply and prepare to make your first cut. Grasp and hold your plate joiner securely with both hands by the front and rear handles.
- Place the fence against the board and align the indicator marks on the fence with the centerline mark(s) on the board.
- Depress the switch trigger to turn the power on your plate joiner, then push it forward to extend the blade into the wood.
- When the base assembly bottoms out against the depth of cut adjustment knob setting, pull back releasing pressure on the spring. Blade will retract from biscuit slot.
- Repeat this procedure for cutting the slot in the mating workpiece.

- Once all biscuit slots have been cut, place a biscuit in each joint and dry assemble the workpieces. Make sure each joint lines up and fits.
- Finally, disassemble the workpieces and place a bead of glue in each slot. Also, spread a bead of glue over the entire surface of the joint. Reinsert the biscuits and assemble the workpieces. See Figure 9.
- Clamp workpieces together until the glue sets up.

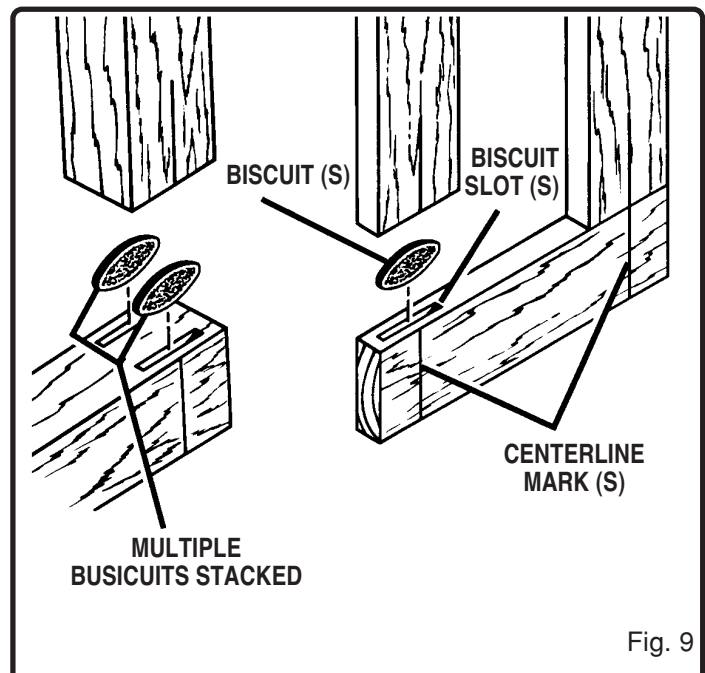

Fig. 9

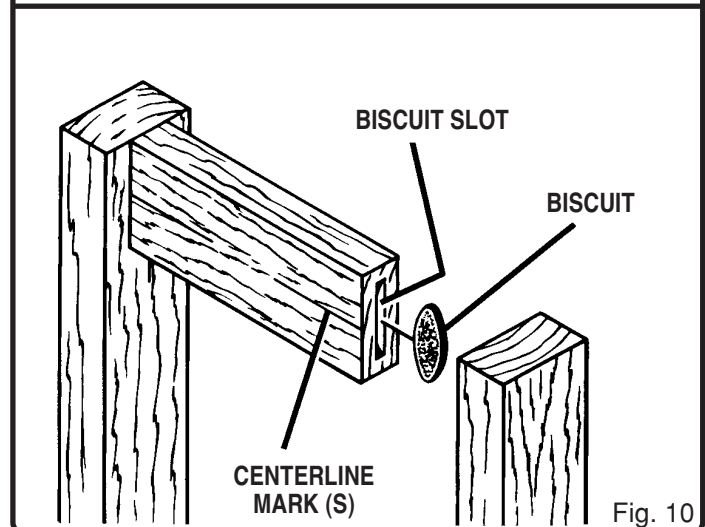

Fig. 10

# OPERATION

## OFFSET BUTT JOINTS

See Figure 10.

The rails of a table or workbench are often offset from the front of the table legs. When offsets are required, it is necessary to cut the slots in the rails first, then re-adjust the fence to cut the slots in the legs.

Keeping this one exception in mind, the procedure for cutting offset butt joints is identical to the procedure for cutting butt joints.

For example — If a 1/4 in. offset is desired, you would mark the centerlines for cutting a butt joint as mentioned in the procedures for cutting butt joints, and cut the slots in the ends of the rails. Next you would raise the fence 1/4 in. to the desired offset and cut the slots in the legs.

## T- JOINTS

See Figures 11-15.

A T-joint is used when the end of a board is joined to the face of another board as shown in figure 11. Attaching shelves to bookcases and inner support braces to frames are typical applications. Actual cutting of a T-joint is as simple as any other cut. However, it is critical that you mark the centerlines, mark the intersection points for each slot, and cut each slot correctly. See Figure 11.

## HOW TO MAKE T- JOINTS

- **Unplug your plate joiner.**
- Place the two pieces of wood to be joined on a level workbench as shown in figure 12. The inside face of the vertical board should be facing up.
- Determine the location of each biscuit joint and mark the centerlines on each board as shown. The centerlines for both boards must line-up with each other. Measure carefully, these measurements must be accurate and precise.

**TIP:** Measure twice and cut once. In addition to the centerlines lining up, the spacing of the biscuit slots from side-to-side must also match.

- Plug your plate joiner into power supply and cut slots in all boards that require end slots. See Figure 13. Follow procedures explained in "**Edge-To-Edge Joints**". Set fence angle at 90°, set fence height at desired dimension on the scale, select the correct depth of cut setting for the biscuit size you plan to use, clamp workpiece securely, then cut each slot at the marked centerline intersection.
- Next, you must adjust the fence on your plate joiner in order to cut slots into the face of the vertical board.

## TO ADJUST FENCE:

- **Unplug your plate joiner.**
- Loosen height adjusting knobs and set fence angle at 0°, set fence height at desired dimension on the scale then retighten height adjustment knobs securely. See Figure 14. Next, select the correct depth of cut setting for the biscuit size you plan to use, clamp workpiece securely, and cut each slot at the marked centerline intersection.

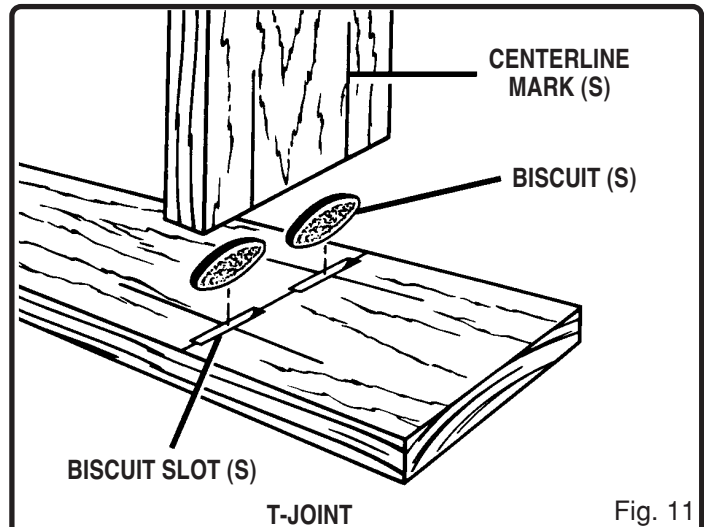

Fig. 11

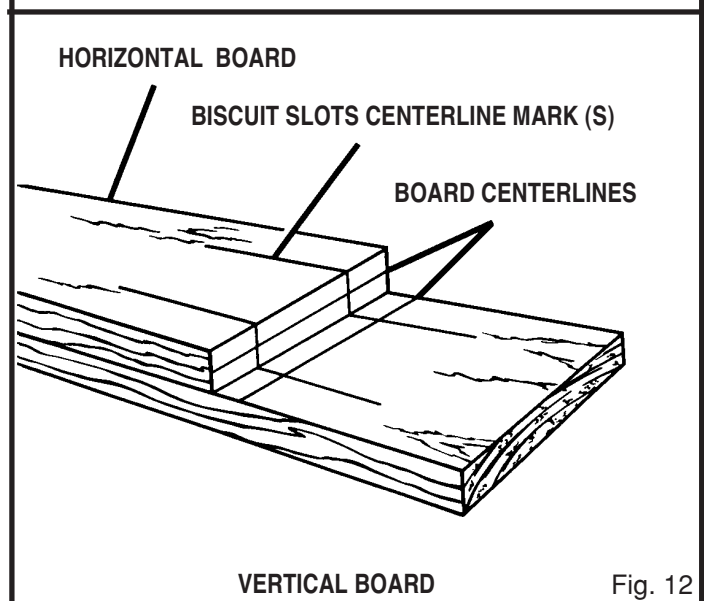

Fig. 12

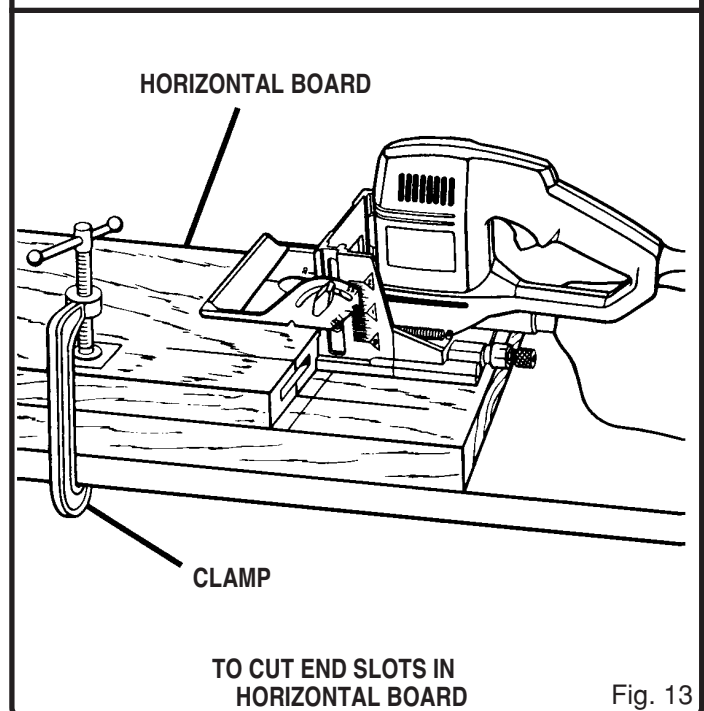

Fig. 13

# OPERATION

- Place your plate joiner on vertical board as shown in figure 15 and align indicator marks on base assembly with centerline on vertical board.
- Place a straight piece of wood on the vertical board and securely clamp it flush against the base assembly. This piece of wood is used for a fence or guide. It must be square with the sides of the vertical board and parallel with the centerline.
- Align centerline on bottom of base assembly with marked intersection for biscuit slot.
- Plug your plate joiner into power supply and prepare to cut slot.
- Depress the switch trigger to turn the power on your plate joiner, then push it down to extend the blade into the wood.
- When the base assembly bottoms out against the depth of cut adjustment knob setting, pull back releasing pressure on the spring. Blade will retract from biscuit slot.

## T-JOINTS

- Repeat this procedure for cutting all required slots in vertical boards.
- Once all slots have been cut, place a biscuit in each joint and dry assemble the workpieces. Make sure each joint lines up and fits.
- Finally, disassemble the workpieces and place a bead of glue in each slot. Also, spread a bead of glue over the entire surface of the joint. Reinsert the biscuits and assemble the workpieces. See Figure 11.
- Clamp workpieces together until the glue sets up.

## MITER JOINTS

See Figures 16-19.

There are two types of miter joints that can be made using biscuits: flat miters and edge miters. Flat miters are used when making picture frames. Edge miters are used when making boxes or things where you don't want to show the end grain of the wood.

**NOTE:** Butt joints show the end grain in wood.

## HOW TO MAKE FLAT MITER JOINTS

- **Unplug your plate joiner.**



### WARNING:

Failure to unplug your plate joiner could result in accidental starting causing possible serious personal injury.

- Place the pieces of wood to be joined on a level workbench as shown in figure 16.
- Using a combination square, draw a line through the center of each joint perpendicular to the mitered edges.
- Set fence angle at 90°, set fence height at desired dimension on the scale, select the correct depth of cut setting for the biscuit size you plan to use, and clamp workpiece securely.

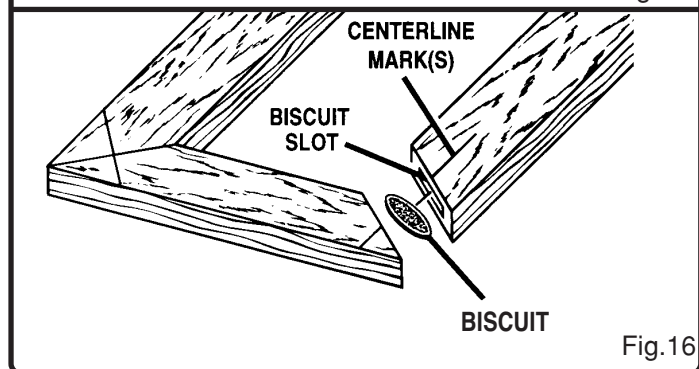
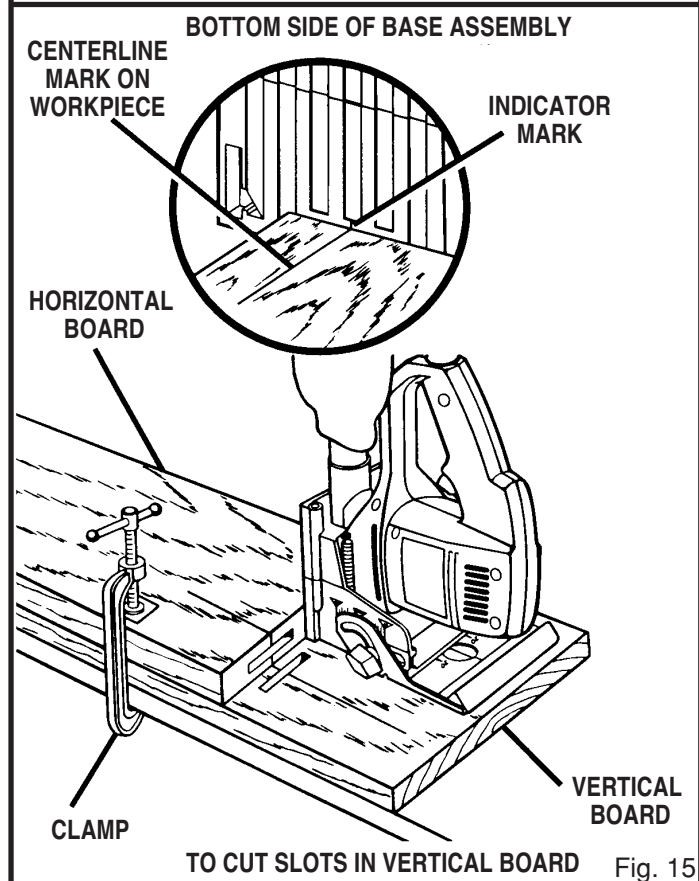
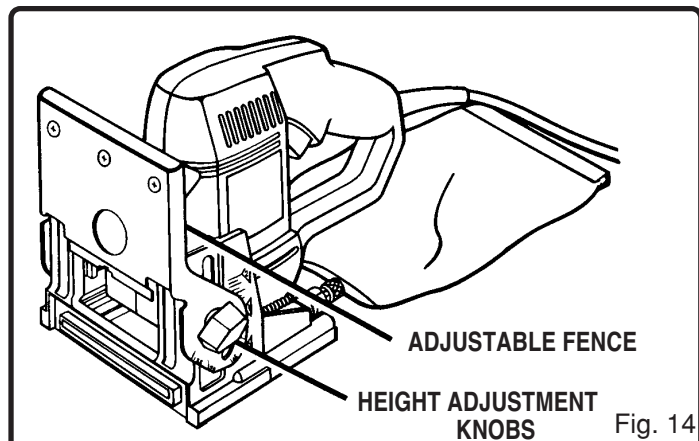

# OPERATION

- Align indicator mark on fence with the centerline on the workpiece.
- Plug your plate joiner into power supply and prepare to cut slot.
- Depress the switch trigger to turn the power on your plate joiner, then push it forward to extend the blade into the wood.
- When the base assembly bottoms out against the depth of cut adjustment knob setting, pull back releasing pressure on the spring. Blade will retract from biscuit slot.
- Repeat this procedure for cutting mating slot and all required miter joint slots.
- Once all slots have been cut, place a biscuit in each joint and dry assemble the workpieces. Make sure each joint lines up and fits.
- Finally, disassemble the workpieces and place a bead of glue in each slot. Also, spread a bead of glue over the entire surface of the joint. Reinsert the biscuits and assemble the workpieces. See Figure 16.
- Clamp workpieces together until the glue sets up.

## HOW TO MAKE EDGE MITER JOINTS

- **Unplug your plate joiner.**
- Place the pieces of wood to be joined on a level workbench as shown in figure 17.
- Mark centerline of the joint on each board.
- When making edge miter joints with workpieces that have different thicknesses, clamp securely to a workbench with the long sides up. This will assure that the outside surfaces will match. See Figure 18.
- Loosen height adjusting knobs and set fence angle at 135°.
- Slide the fence up or down until fence height is at desired setting.
- Tighten height adjustment knobs securely.
- Place your plate joiner on workpiece with the adjustable fence resting on the long side of workpiece as shown in figure 18. The base or vertical fence should be against the mitered edge of the workpiece.
- Recheck fence height setting to make sure it will not cut through the workpiece.
- Align indicator mark on fence with the centerline on the workpiece. Make sure the base or vertical fence is pressed flat against the mitered edge of the workpiece.
- Plug your plate joiner into power supply and prepare to cut slot.
- Depress the switch trigger to turn the power on your plate joiner, then push it forward to extend the blade into the wood.
- When the base assembly bottoms out against the depth of cut adjustment knob setting, pull back releasing pressure on the spring. Blade will retract from biscuit slot.
- Repeat this procedure for cutting mating slot and all required miter joint slots.

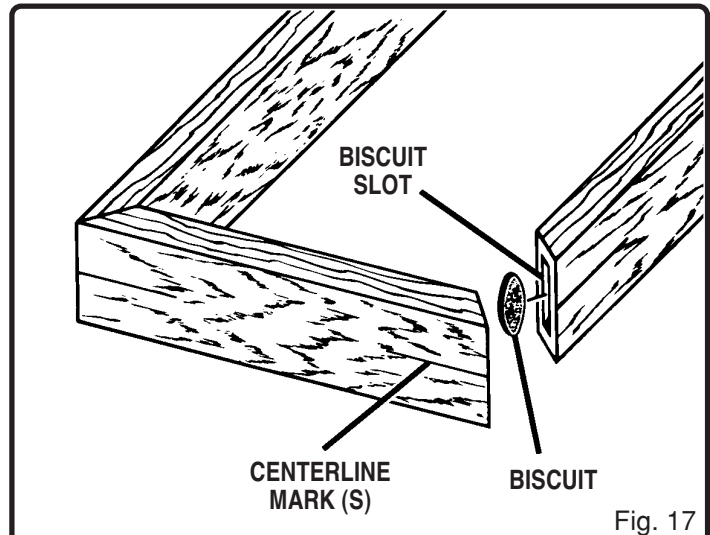

CUTTING EDGE MITER SLOT  
FROM LONG SIDE OF WORKPIECE

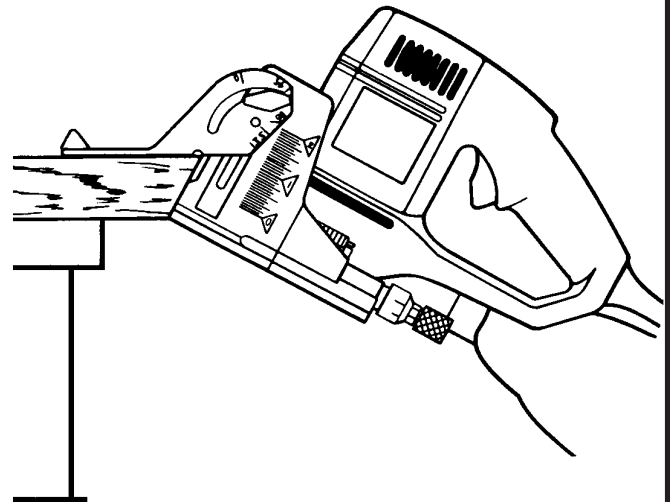

Fig. 18

CUTTING EDGE  
MITER SLOT  
FROM SHORT SIDE  
OF WORKPIECE

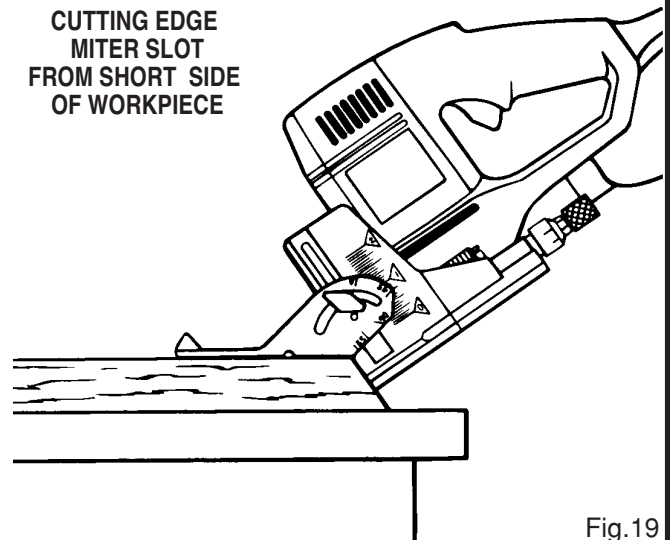

Fig. 19

# OPERATION

- Once all slots have been cut, place a biscuit in each joint and dry assemble the workpieces. Make sure each joint lines up and fits.
- Finally, disassemble workpieces and place a bead of glue in each slot. Also, spread a bead of glue over the entire surface of the joint. Reinsert the biscuits and assemble workpieces. See Figure 17.
- Clamp workpieces together until the glue sets up.

If the workpieces are the same thickness, clamp securely to a workbench with the short sides up. See Figure 19. Set fence angle at 45°. Place your plate joiner on the workpiece with the adjustable fence resting on the short side of the workpiece and the base or vertical fence against the mitered edge of the workpiece. Follow steps 9-17 above to cut required slots.

**REMEMBER:** Before cutting slots, make sure blade will not cut through the workpiece and that both the vertical and horizontal fences are pressed flat against the mitered edge and face of the workpiece.

## DUSTLESS FEATURE

See Figure 20.

The dust bag located on the rear of your plate joiner provides a dust collection system. Wood particles are drawn up through a tunnel in the base and collect in the dust bag during cutting operations. For more efficient operation, empty dust bag when half full.

Do not connect plate joiner to power supply before installing dust bag.



## WARNING:

To prevent the possibility of sawdust or foreign objects being thrown into your face and eyes, never attempt to use your plate joiner without dust bag properly installed. Sawdust or foreign objects being thrown into your face and eyes could result in possible serious injury.

## TO INSTALL DUST BAG

The dust bag can be installed by inserting the dust bag adaptor inside the blower exhaust. See Figure 20.

## TO EMPTY DUST BAG

Remove dust bag from plate joiner, remove retainer strip and shake out dust. Occasionally turn the dust bag inside out and brush the accumulation of dust from the inside of the bag. This will permit the air to flow through the bag better.

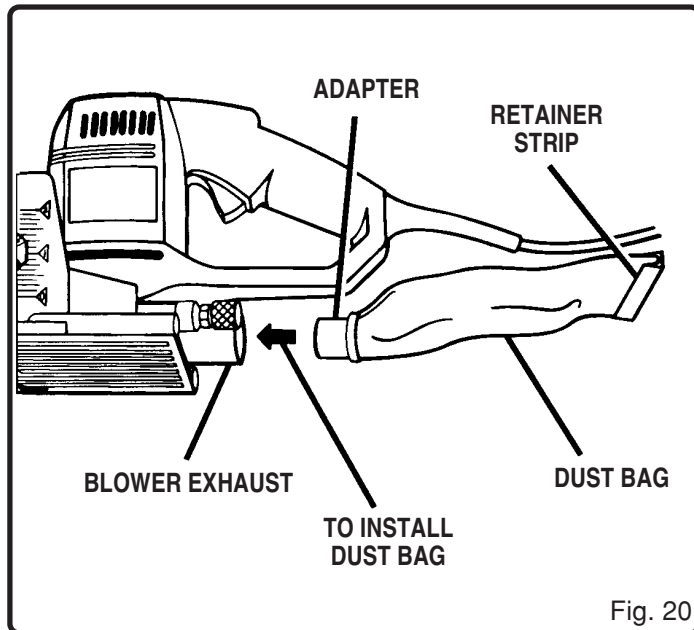

Fig. 20

## HELPFUL HINTS

- Always clamp workpiece securely before cutting.
- A safe operator is one who thinks ahead.
- Always wear eye protection when cutting slots.
- Make set-up adjustments carefully. Then double check. Measure twice and cut once.
- Always dry assemble your project before gluing it together.
- The more biscuits used, the stronger the joint will be.
- Keep blade clean and properly sharpened.
- Don't let familiarity make you careless.
- Study all safety rules and do the job safely.
- **NEVER** place your hands in jeopardy.
- Make certain clamps can't loosen while in use.
- Test difficult set-ups on scrap—Don't waste lumber.
- Plan each operation before you begin.
- Provide for smoother operation by cleaning your plate joiner frequently. Shake plate joiner or blow with an air jet to remove wood particle build-up.
- Empty dust bag when half full.
- **DO NOT ABUSE POWER TOOLS.** Abusive practices can damage tool as well as workpiece.
- **THINK SAFETY BY THINKING AHEAD.**

## LUBRICATION

All of the bearings in this tool are lubricated with a sufficient amount of high grade lubricant for the life of the unit under normal operating conditions. Therefore, no further lubrication is required.



# MAINTENANCE

## **WARNING:**

When servicing, use only identical Ryobi replacement parts. Use of any other part may create a hazard or cause product damage.

## **CLEANING BASE ASSEMBLY / DUST BAG TUNNEL**

See Figures 21-23.

After extended use, wood particles and resin may build up inside the base assembly of your plate joiner and clog the path for wood particles going into dust bag. Wood particles packing up in this area, not only defeats the dustless feature of your plate joiner, it also makes cutting biscuit slots more difficult.

## **HOW TO CLEAN BASE ASSEMBLY**

- Unplug your plate joiner.

## **WARNING:**

Failure to unplug your plate joiner could result in accidental starting causing possible serious personal injury.

- Remove dust bag.
- Place your plate joiner upside down on a workbench as shown in figure 21.
- Using a screwdriver remove the two screws securing front base assembly.
- Pull adjustable fence in the direction shown by the arrow in figure 21 and remove front base assembly.
- Using a pair of needle nose pliers, stretch and release springs from tabs on bearing plate. See Figure 22.
- Push adjustment rod away from bearing plate and remove rear base assembly.
- With front and rear base assemblies removed, place your plate joiner upside down on a workbench and clean wood particles and resin from blade, bearing plate and surrounding areas.

## **CAUTION:**

Be aware of cut hazard, carbide tips on blade are sharp.

- Clean wood particles and resin from slots and surrounding areas on front and rear base assemblies. See Figure 23. Apply a thin coat of general purpose grease in slots or on bearing plate where base slides.
- Replace rear base assembly. Position adjustment rod in its proper place as shown in figure 22.
- Secure rear base assembly in place with the two springs. Hook one end of each spring in notch on each side of base assembly. Using needle nose pliers, stretch each spring and hook it over tabs on bearing plate.

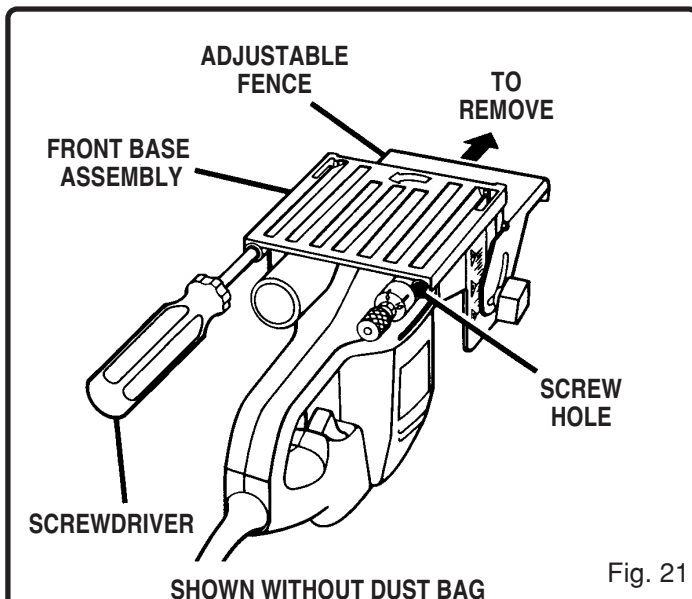

Fig. 21

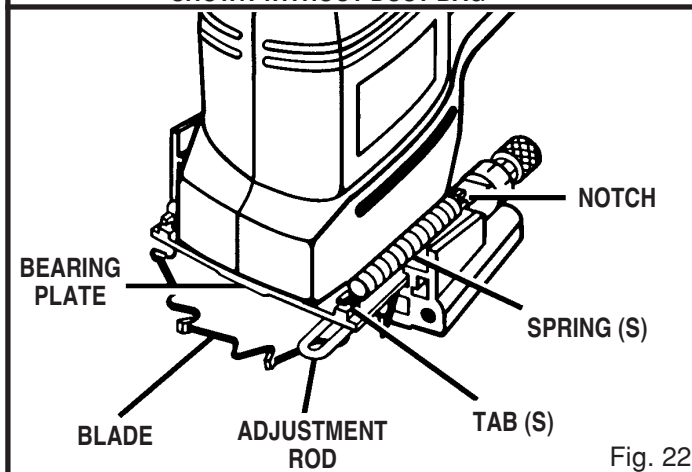

Fig. 22

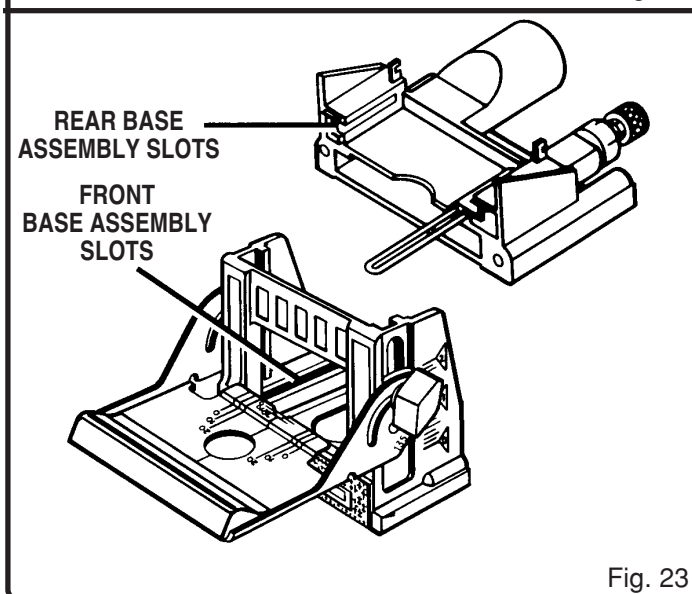

Fig. 23

- Reassemble front base assembly.
- Replace screws and tighten securely with a screwdriver.
- Replace dust bag.

# MAINTENANCE

## BLADE REPLACEMENT

See Figures 24-27.

After extended use, the blade on your plate joiner may become dull and need replacing. If you accidentally hit a nail or other blunt object, it will break the carbide tips on the blade. These situations also require replacing the blade.

### HOW TO REPLACE THE BLADE

- Unplug your plate joiner.

#### **WARNING:**

Failure to unplug your plate joiner could result in accidental starting causing possible serious personal injury.

- Remove dust bag.
- Place your plate joiner upside down on a workbench as shown in figure 24.
- Using a screwdriver remove the two screws securing front base assembly.
- Pull adjustable fence in the direction shown by the arrow in figure 24 and remove front base assembly.
- Using a pair of needle nose pliers, stretch and release springs from tabs on bearing plate. See Figure 25.
- Push adjustment rod away from bearing plate and remove rear base assembly.
- With base assemblies removed, place plate joiner upside down on a workbench as shown in figure 26.
- Place a Phillips screwdriver in one of the two holes provided in bearing plate.
- Place one of the non-cutting teeth located behind each carbide tipped cutting tooth against the screwdriver or pin and lock blade preventing it from rotating. **DO NOT lock blade against one of the cutting teeth. Carbide tips will break.**
- Using a 3/16 in. wrench, remove blade screw.
- **NOTE:** Turn blade screw counterclockwise to remove. See Figure 27.
- Remove outer blade washer and blade.
- Clean wood particles and resin from blade washer, dust bag area, base assembly slots, and all surrounding parts.

#### **WARNING:**

If inner blade washer has been removed, replace it before installing new blade. Failure to do so could cause an accident since blade screw will not tighten properly.

- Place inner blade washer on gear spindle. See Figure 27.
- Place new blade onto shoulder of blade washer and secure with outer blade washer and blade screw.
- **NOTE:** Blade screw fits into cupped side of outer blade washer.

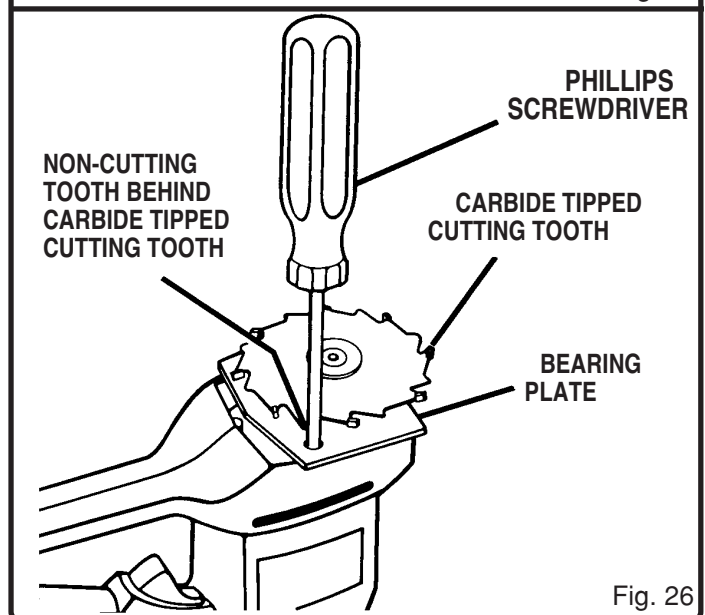
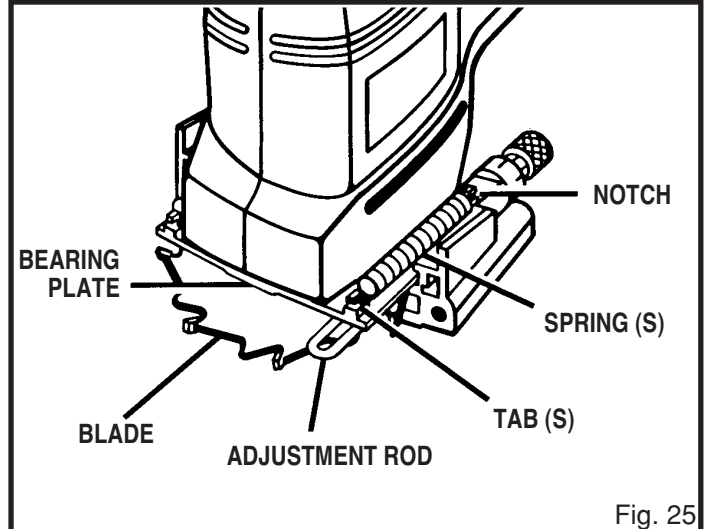
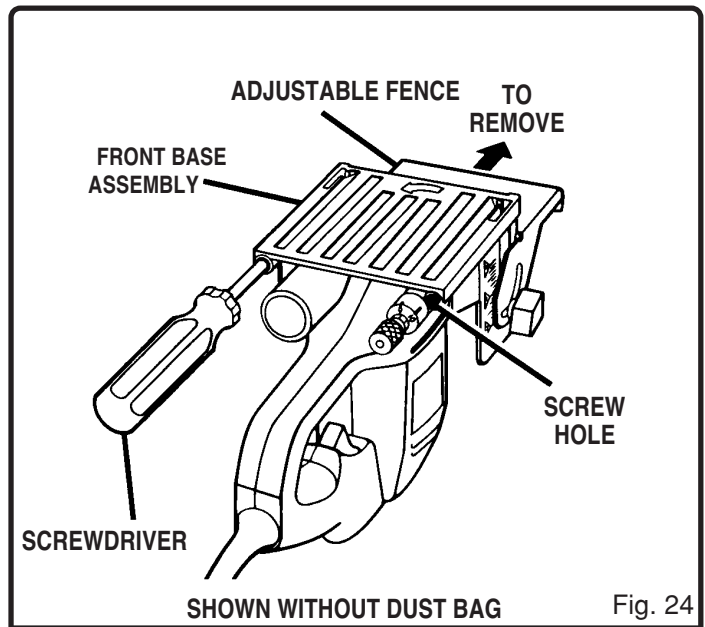

# MAINTENANCE

## HOW TO REPLACE THE BLADE (Continued)

**NOTE:** Blade teeth point toward the right of the tool when held in normal operating position. The direction of rotation is marked on the joiner blade. An arrow on the bottom of the front base assembly also indicates direction of rotation. See Figure 24.

- Tighten blade screw securely.
- NOTE:** Turn blade screw clockwise to tighten.
- Replace rear base assembly. Position adjustment rod in its proper place as shown in figure 25.
- Secure rear base assembly in place with the two springs. Hook one end of each spring in notch on each side of base assembly. Using needle nose pliers, stretch each spring and hook it over tabs on bearing plate.
- Reassemble front base assembly.
- Replace screws and tighten securely with a screwdriver.
- Replace dust bag.

Avoid using solvents when cleaning plastic parts. Most plastics are susceptible to damage from various types of commercial solvents and may be damaged by their use. Use clean cloths to remove dirt, dust, oil, grease, etc.

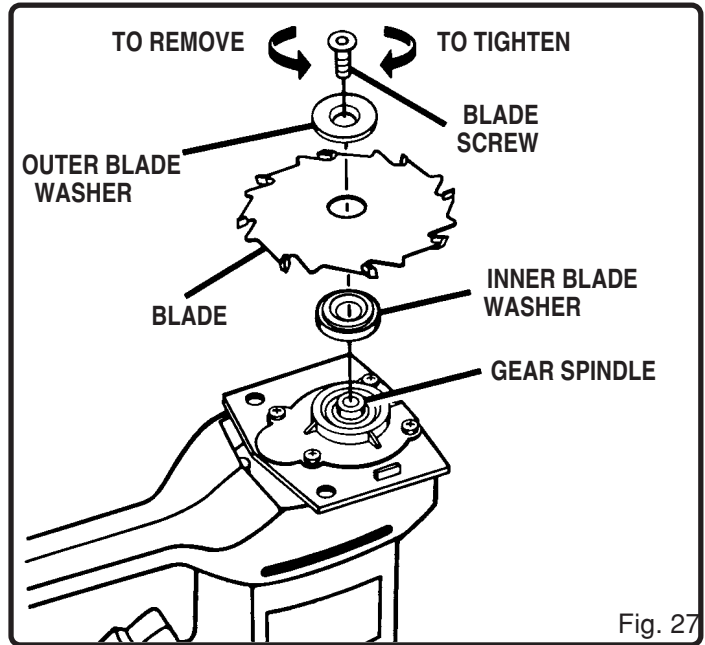

Fig. 27

When electric tools are used on fiberglass it has been found that they are subject to accelerated wear and possible premature failure, as the fiberglass chips and grindings are highly abrasive to bearings, brushes, commutator, etc. Consequently it is not recommended that this tool be used for extended work on any fiberglass material. During any use on fiberglass it is extremely important that the tool is cleaned frequently by blowing with an air jet.

### **WARNING:**

Do not at any time let brake fluids, gasoline, petroleum-based products, penetrating oils, etc. come in contact with plastic parts. They contain chemicals that can damage, weaken or destroy plastic.

### **WARNING:**

Always wear safety goggles or safety glasses with side shields during power tool operation or when blowing dust. If operation is dusty, also wear a dust mask.

# ACCESSORIES

The following recommended accessories are current and were available at the time this manual was printed:

Catalog No.	Description	Quantity
4600020	Size 0 Biscuits	100 Pcs.
4600021	Size 10 Biscuits	100 Pcs.
4600022	Size 20 Biscuits	100 Pcs.
4600023	Assortment Biscuits	Total 400 Pcs.
	Includes:	
	Size 0	100 Pcs.
	Size 10	100 Pcs.
	Size 20	200 Pcs.

# TROUBLESHOOTING

## PROBLEM

## SOLUTION

- 
- | PROBLEM   | SOLUTION   |
|---|--|
| 1. Biscuits do not fit slots. Biscuits not fitting slots may also cause misalignment of boards being joined.  | <ul style="list-style-type: none"><li>A. Biscuit slots are too deep or too shallow. Make fine adjustments to depth setting. See "<b>TO MAKE FINE ADJUSTMENTS</b>" section on page 9.</li><li>B. Biscuit thickness may be out of tolerance. Compress biscuits in a vise if they are too thick.</li><li>C. Check to see if biscuits are the correct size for the size slots that have been cut: #0, #10, or #20.</li><li>D. Check to see if biscuits have gotten wet and swollen.</li></ul>  |
| 2. Wood particles begin to backup on front of unit.   | <ul style="list-style-type: none"><li>A. Dust collection system is not functioning properly. Dust bag may be full. Empty dust bag often. See "<b>TO EMPTY DUST BAG</b>" and "<b>TO INSTALL DUST BAG</b>" sections on page 16.</li><li>B. The tunnel in the base may be clogged preventing wood particles from being drawn into the dust bag. Remove front and rear base assemblies and clean blade, bearing plate, base assembly slots, and surrounding areas. See "<b>CLEANING BASE ASSEMBLY / DUST BAG TUNNEL</b>" section on page 17.</li></ul> |
| 3. Blade becomes difficult to push in when cutting slots. Blade does not retract properly when cutting slots. | <ul style="list-style-type: none"><li>A. Wood particles and resin have built up on base assembly slots and surrounding areas. Remove front and rear base assemblies and clean blade, bearing plate, base assembly slots and surrounding areas. Apply a thin coat of general purpose grease in slots or on bearing plate where base slides. See "<b>CLEANING BASE ASSEMBLY / DUST BAG TUNNEL</b>" section on page 17.</li></ul>   |
| 4. Cutting performance is poor and there is a loss of power or stalling of motor when cutting slots.          | <ul style="list-style-type: none"><li>A. Blade is dull. Replace blade. See "<b>BLADE REPLACEMENT</b>" section on pages 18 and 19.</li><li>B. Resin has built up on blade. Remove blade and clean blade with gum and pitch remover. See "<b>BLADE REPLACEMENT</b>" section on pages 18 and 19 for removing blade to clean and replacing blade.</li></ul>  |
-





# OPERATOR'S MANUAL

## PLATE JOINER

### JM81-1

### DOUBLE INSULATED

- **SERVICE**

Now that you have purchased your tool, should a need ever exist for repair parts or service, simply contact your nearest Ryobi Authorized Service Center. Be sure to provide all pertinent facts when you call or visit. Please call 1-800-525-2579 for your nearest Ryobi Authorized Service Center. You can also check our web site at [www.ryobitools.com](http://www.ryobitools.com) for a complete list of Authorized Service Centers.

- **MODEL NO.**

The model number of your tool will be found on a plate attached to the motor housing. Please record the model number and serial number in the space provided below.

- MODEL NUMBER JM81-1
- SERIAL NUMBER \_\_\_\_\_

**RYOBI TECHNOLOGIES, INC.**

1428 Pearman Dairy Road Anderson SC 29625  
Post Office Box 1207, Anderson SC 29622-1207  
Phone 1-800-525-2579  
[www.ryobitools.com](http://www.ryobitools.com)