

**RYOBI
HAND PLANER
MODEL NO. HPL51
REPAIR SHEET**

RYOBI HAND PLANER – MODEL NUMBER HPL51

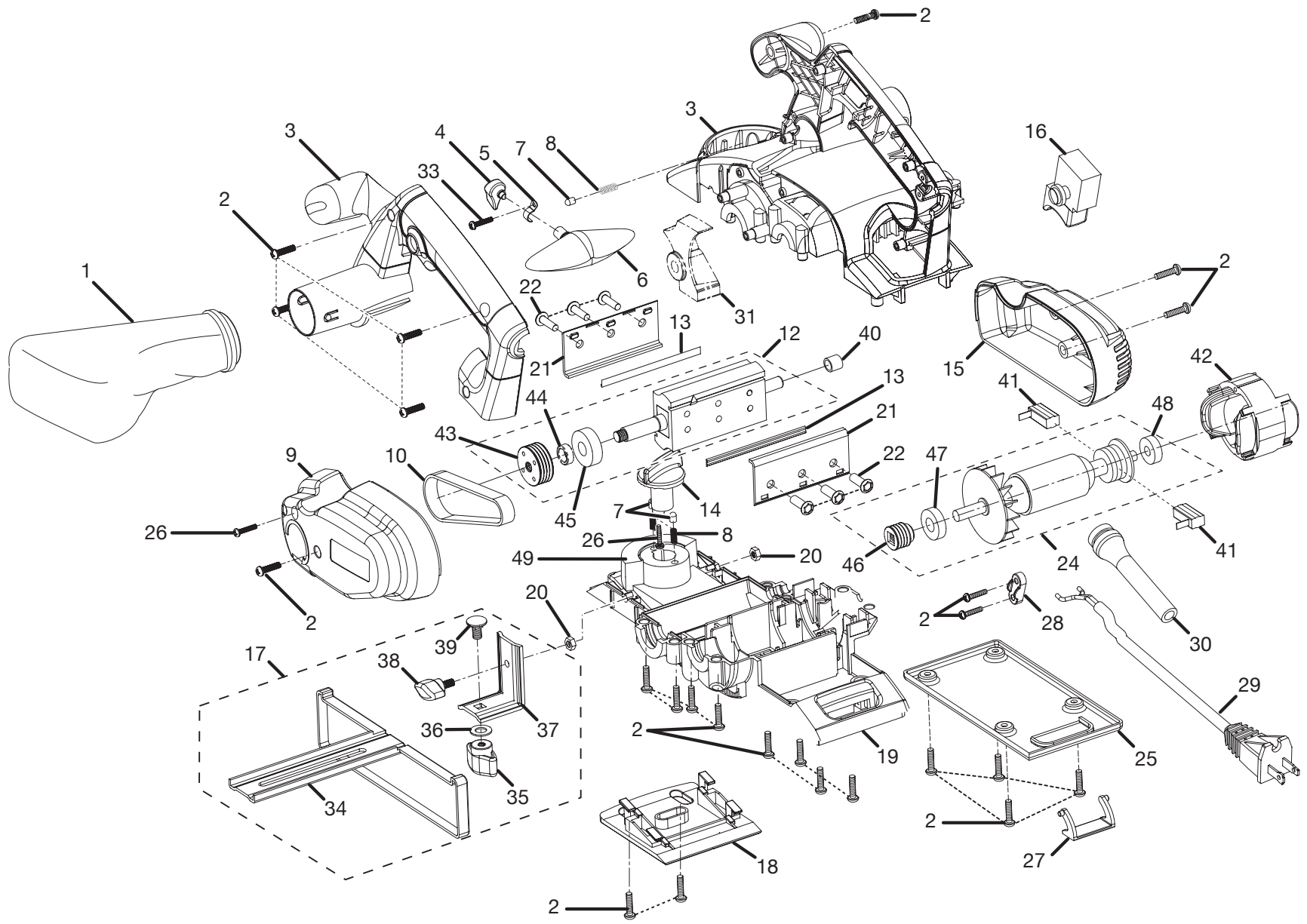

RYOBI HAND PLANER – MODEL NUMBER HPL51

The model number will be found on a plate attached to the motor housing. Always mention the model number in all correspondence regarding your **HAND PLANER** or when ordering repair parts.

PARTS LIST

KEY NO.	PART NUMBER	DESCRIPTION	QTY.	KEY NO.	PART NUMBER	DESCRIPTION	QTY.
1	300027037	DUST BAG ASSEMBLY	1	27	590847002	KICK STAND	1
2	6620805	* SCREW (M4 X 16 mm)	24	28	5950101	CORD CLAMP	1
3	200237002	HOUSING ASSEMBLY	1	29	730377001	POWER CORD	1
4	590840002	DUST DIRECTIONAL KNOB.....	1	30	5927402	BEND RELIEF	1
5	690882001	AIR DEFLECTOR CLAMP.....	1	31	511917001	AIR CHANNEL COVER.....	1
6	590844001	AIR DEFLECTOR PLATE	1	32	690214003	WRENCH (NOT SHOWN)	1
7	690541001	COPPER CAP.....	3	33	660008003	* SCREW (M3 X 14 mm)	1
8	690542001	SPRING	3	34	690866001	EDGE GUIDE	1
9	400838001	BELT COVER	1	35	540510002	KNOB NUT	1
10	560950001	BELT	1	36	5228001	FLAT WASHER	1
11	940304011	LOGO PLATE (NOT SHOWN).....	1	37	690865001	ADJUSTING PLATE	1
12	200241001	CUTTER BLOCK ASSEMBLY.....	1	38	540511002	KNOB BOLT.....	1
13	690861001	CUTTER BLADE	2	39	660142001	CARRIAGE BOLT (M6 X 12 mm)	1
14	590843002	DEPTH ADJUSTMENT KNOB	1	40	680727001	NEEDLE BEARING (8 X W8).....	1
15	590839001	MOTOR COVER	1	41	290069042	BRUSH ASSEMBLY	2
16	760304003	SWITCH.....	1	42	740483001	FIELD.....	1
17	300869001	EDGE GUIDE ASSEMBLY (INCL. KEY NOS. 34 - 39).....	1	43	610334001	DRIVEN PULLEY	1
18	640601001	FRONT SHOE	1	44	671157001	BRASS SPACER.....	1
19	590833002	HOUSING SUPPORT	1	45	6807001	BALL BEARING	1
20	670970001	* HEX NUT (M5)	2	46	610333001	DRIVING PULLEY	1
21	690862002	BLADE CLAMP.....	2	47	680999009	BALL BEARING (607 2Z)	1
22	660302004	* SCREW (10-24 X 3/4 in. BUTTON HD.)..	6	48	680414008	BALL BEARING (6900 2Z)	1
23	940078032	DATA PLATE (NOT SHOWN).....	1	49	940266007	DEPTH ADJUSTMENT LABEL	1
24	200216005	ARMATURE ASSEMBLY.....	1	50	940299828	WARNING LABEL, CORD	1
25	690863001	REAR SHOE	1		983000285	OPERATOR'S MANUAL	
26	6620311	* SCREW (M3 X 20 mm)	2		983000285R	REPAIR SHEET (REV:03)	
					05-16-05		

WARNING: Improper repair of a double insulated tool can result in damage to the double insulation system possibly causing electrical shock or electrocution. Any repairs requiring disassembly of your tool requires safety testing and should only be performed by a Ryobi Authorized Service Center nearest you call 1-800-525-2579

* STANDARD HARDWARE ITEM – MAY BE PURCHASED LOCALLY.

RYOBI HAND PLANER – MODEL NUMBER HPL51

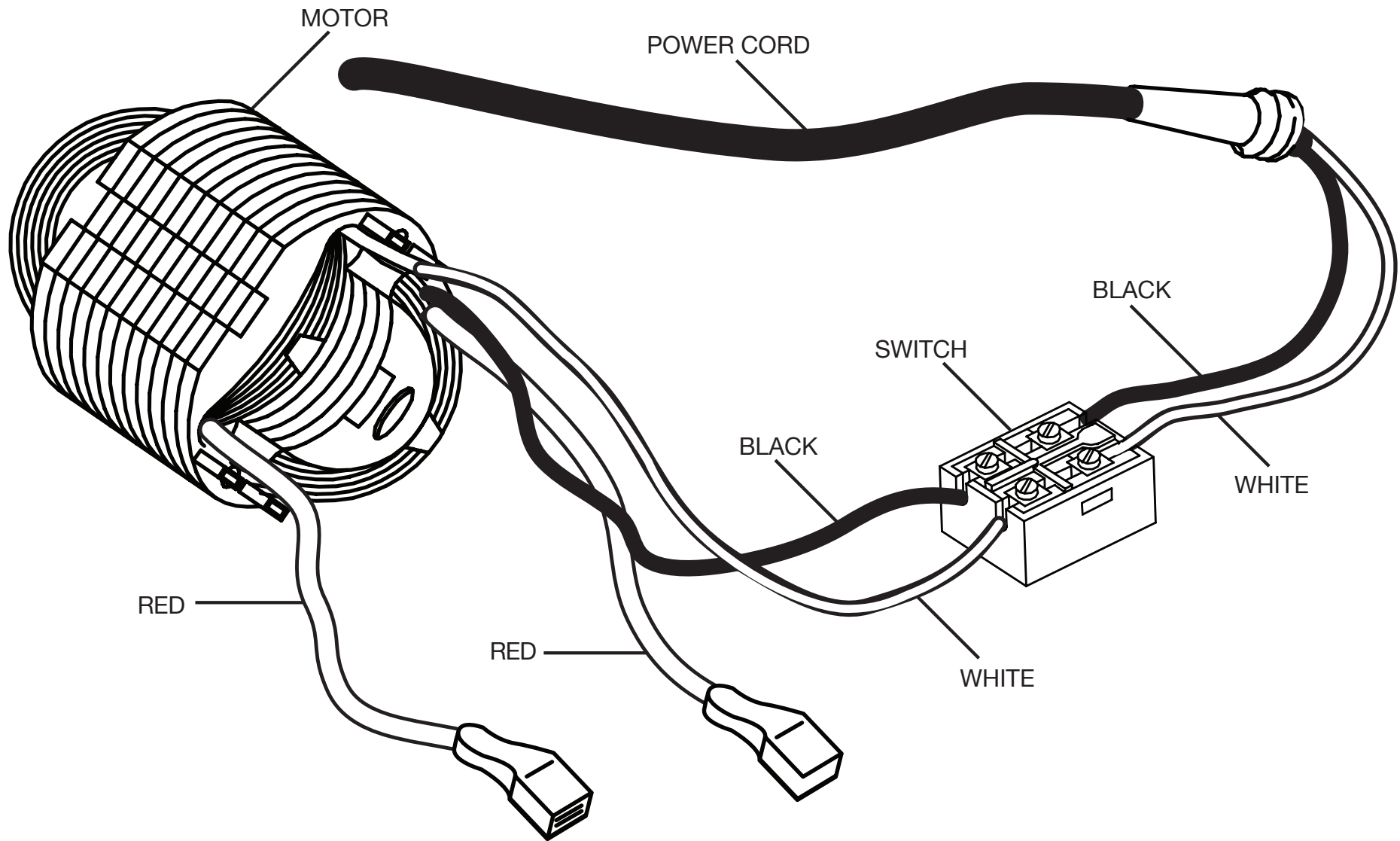

WIRING DIAGRAM