

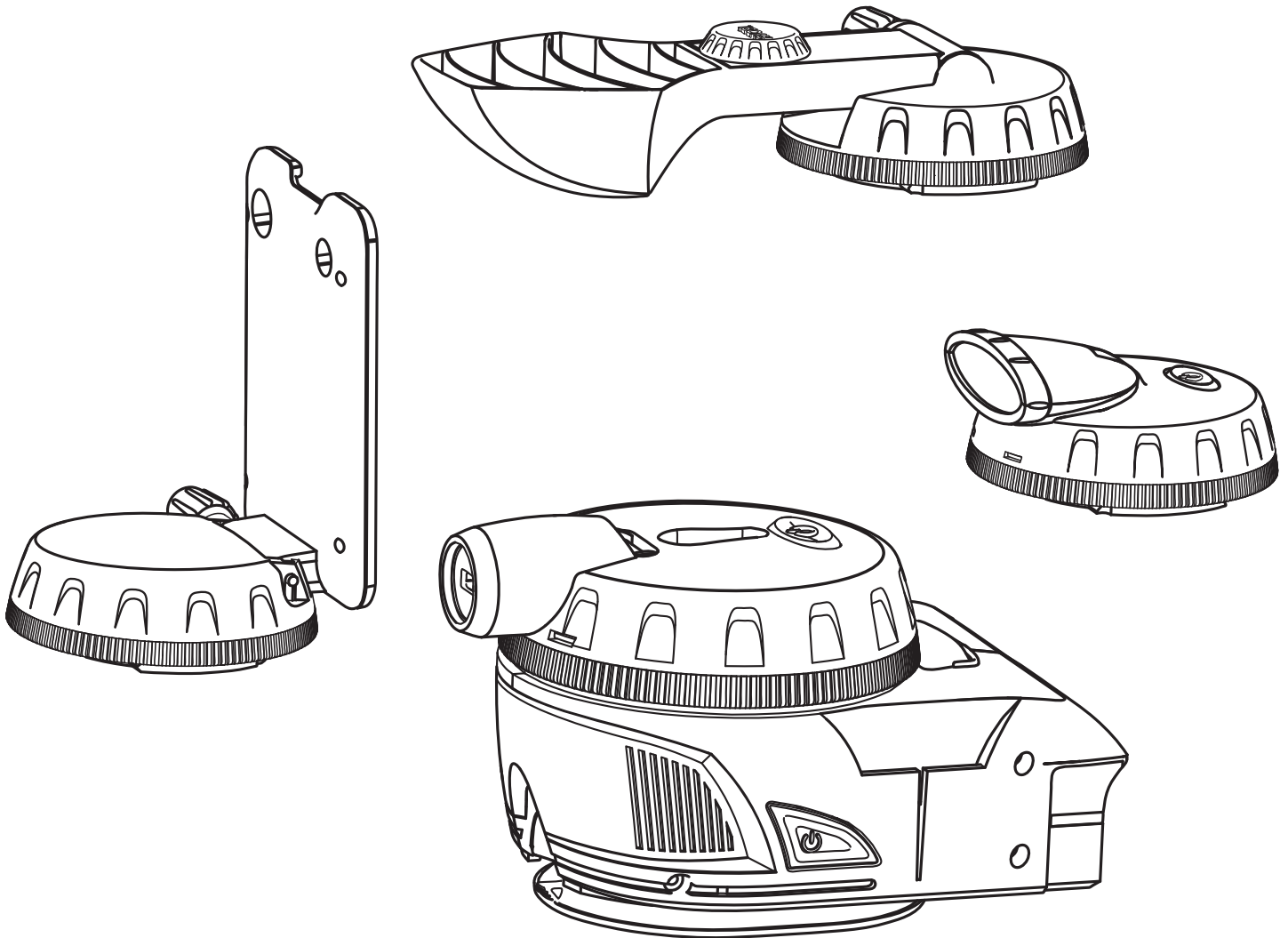

# OPERATOR'S MANUAL

## AIRgrip MultiTASKit™

EMM0001



Your product has been engineered and manufactured to Ryobi's high standard for dependability, ease of operation, and operator safety. When properly cared for, it will give you years of rugged, trouble-free performance.

**⚠ WARNING:** To reduce the risk of injury, the user must read and understand the operator's manual before using this product.

Thank you for buying a Ryobi product.

**SAVE THIS MANUAL FOR FUTURE REFERENCE**

# TABLE OF CONTENTS

■ Introduction .....	2
■ General Safety Rules .....	3
■ Symbols .....	4-5
■ Features .....	6-7
■ Assembly .....	8
■ Operation .....	8-12
■ Maintenance .....	13
■ Troubleshooting .....	14
■ Parts Ordering / Service .....	16

## INTRODUCTION

This tool has many features for making its use more pleasant and enjoyable. Safety, performance, and dependability have been given top priority in the design of this product making it easy to maintain and operate.

**Please visit our website at  
[www.ryobitools.com](http://www.ryobitools.com) to register this product.**

**Model No. EMM0001**

# GENERAL SAFETY RULES

## **WARNING!**

**READ AND UNDERSTAND ALL INSTRUCTIONS.** Failure to follow all instructions listed below, may result in electric shock, fire and/or serious personal injury.

## **CAUTION:**

Use of controls or adjustments or performance of procedures other than those specified herein may result in hazardous radiation exposure.

## **CAUTION:**

The use of an optical instrument with this product will increase eye hazard.











The laser guide radiation used in the laser level attachment is Class IIIa with < 5mW and 635 nm wavelengths. These lasers do not normally present an optical hazard, although staring at the beam may cause flash blindness.

- Avoid direct eye exposure when using the laser and do not project the laser beam directly into the eyes of others. Serious eye injury could result.
- Do not remove or deface any product labels. Removing product labels increases the risk of exposure to laser radiation.
- Do not place the unit in a position that may cause anyone to stare into the laser beam intentionally or unintentionally. Serious eye injury could result.
- Do not operate the laser level around children or allow children to operate the tool. Serious eye injury could result.

- Always turn the laser level off when not in use. Leaving the tool on increases the risk of someone inadvertently staring into the laser beam.
- Do not operate the unit in combustible areas such as in the presence of flammable liquids, gasses or dust.
- Always ensure the laser beam is aimed at a surface without reflective properties. Shiny reflective materials are not suitable for laser use.
- When using the base, always check to be sure the unit is securely seated. Damage to the tool and/or serious injury to the user could result if the unit falls.
- Handle the unit with care. Treat it as you would any other optical device such as a camera or binoculars.
- Avoid exposing the unit to shock, continuous vibration or extreme hot or cold temperatures. Damage to the tool and/or serious injury to the user could result.
- The amount of weight being supported by the vacuum base and/or helping hand should not exceed product specifications. A greater weight may cause the product to fail, which could cause damage to both the unit and the workpiece being supported.
- When using the magnetic base, be cautious of putting too many or too heavy objects on the surface.
- Do not look directly into the LEDs on the lighting attachment. The brightness of the light could cause temporary blindness.
- Save these instructions. Refer to them frequently and use them to instruct others who may use this product. If you loan someone this unit, loan them these instructions also.



# SYMBOLS

Some of the following symbols may be used on this tool. Please study them and learn their meaning. Proper interpretation of these symbols will allow you to operate the tool better and safer.

SYMBOL	NAME	DESIGNATION/EXPLANATION
V	Volts	Voltage
A	Amperes	Current
Hz	Hertz	Frequency (cycles per second)
W	Watt	Power
min	Minutes	Time
~	Alternating Current	Type of current
==	Direct Current	Type or a characteristic of current
$n_0$	No Load Speed	Rotational speed, at no load
	Class II Construction	Double-insulated construction
.../min	Per Minute	Revolutions, strokes, surface speed, orbits etc., per minute
	Wet Conditions Alert	Do not expose to rain or use in damp locations.
	Read The Operator's Manual	To reduce the risk of injury, user must read and understand operator's manual before using this product.
	Eye Protection	Always wear safety goggles, safety glasses with side shields, or a full face shield when operating this product.
	Safety Alert	Precautions that involve your safety.
	No Hands Symbol	Failure to keep your hands away from the blade will result in serious personal injury.
	No Hands Symbol	Failure to keep your hands away from the blade will result in serious personal injury.
	No Hands Symbol	Failure to keep your hands away from the blade will result in serious personal injury.
	No Hands Symbol	Failure to keep your hands away from the blade will result in serious personal injury.
	Hot Surface	To reduce the risk of injury or damage, avoid contact with any hot surface.

# SYMBOLS

The following signal words and meanings are intended to explain the levels of risk associated with this product.

SYMBOL	SIGNAL	MEANING
	<b>DANGER:</b>	Indicates an imminently hazardous situation, which, if not avoided, will result in death or serious injury.
	<b>WARNING:</b>	Indicates a potentially hazardous situation, which, if not avoided, could result in death or serious injury.
	<b>CAUTION:</b>	Indicates a potentially hazardous situation, which, if not avoided, may result in minor or moderate injury.
	<b>CAUTION:</b>	(Without Safety Alert Symbol) Indicates a situation that may result in property damage.

## SERVICE

This unit has no serviceable parts. If the unit fails due to normal wear and tear within two years of purchase, return with original receipt for a replacement unit at no charge. Call 1-800-525-2579 for your nearest **RYOBI AUTHORIZED SERVICE CENTER**.



## WARNING:

To avoid serious personal injury, do not attempt to use this product until you read thoroughly and understand completely the operator's manual. Save this operator's manual and review frequently for continuing safe operation and instructing others who may use this product.

## SAVE THESE INSTRUCTIONS

# FEATURES

## PRODUCT SPECIFICATIONS

### Vacuum Base

Recommended Use..... Indoors  
 Power Supply .....2 AA, 1.5 Volt Batteries  
 Battery Life ..... 4 Hours Continuous Use - Alkaline Batteries  
 Operating Temperature..... 32°F to 104°F  
 Weight Capacity ..... 15 lbs.

### Laser Head

Length of Laser Line..... Up to 30 ft.  
 Laser..... Class IIIa, < 5mW, 635 nm  
 Power Supply .....2 AA, 1.5 Volt Batteries  
 Battery Life ..... 40 Hours Continuous Use - Alkaline Batteries  
 Accuracy..... ± 1/2 in. at 20 ft.

### Lighting Head

Power Supply .....2 AA, 1.5 Volt Batteries  
 Battery Life ..... 30 Hours Continuous Use - Alkaline Batteries

### Helping Hand

Weight Capacity ..... 12 lbs.  
 Extension Capacity..... 3 in.

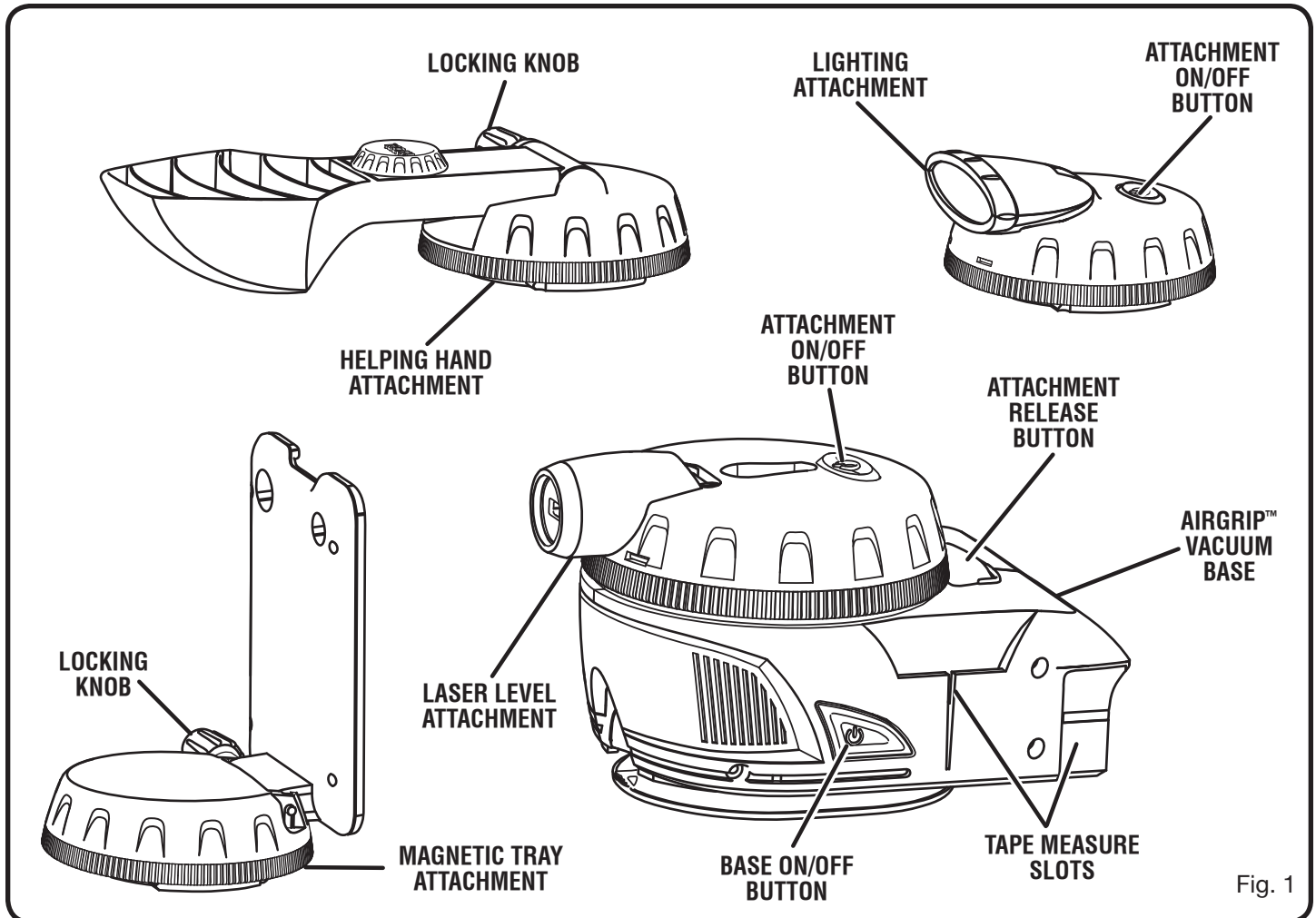

Fig. 1

# FEATURES

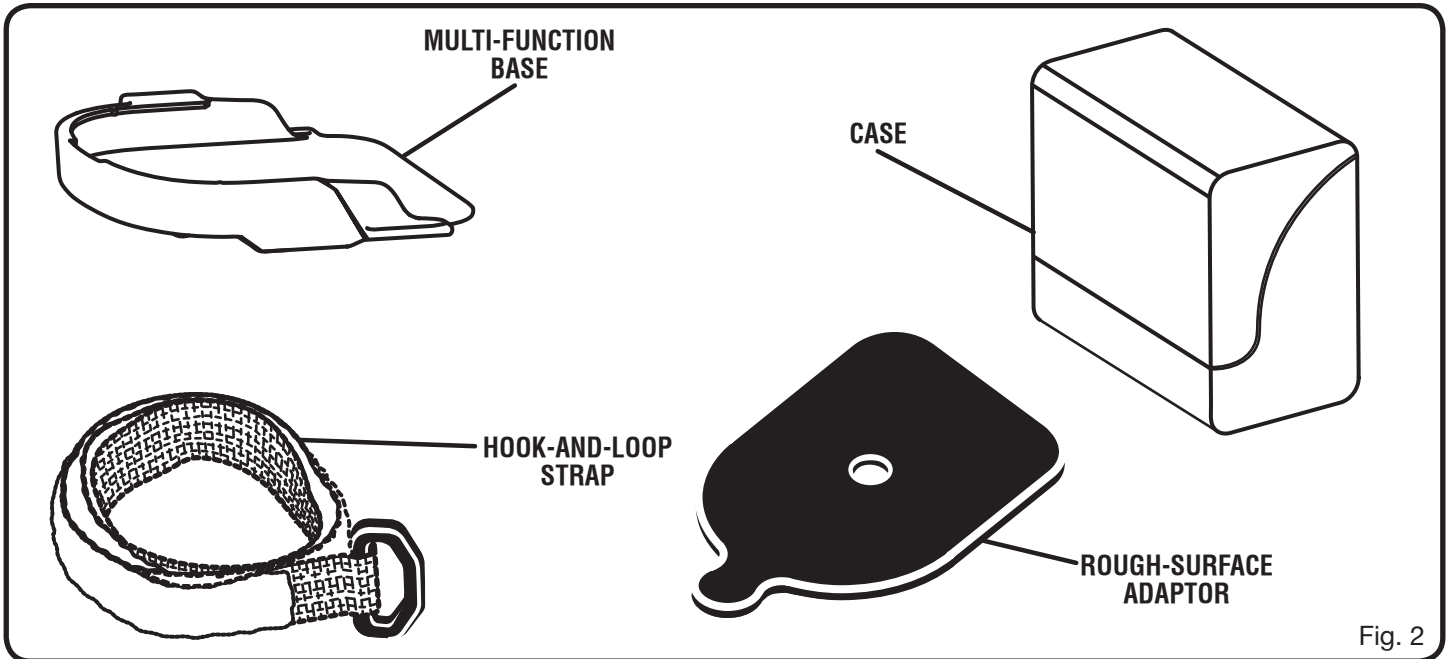

Fig. 2

## KNOW YOUR MULTITASKIT™

See Figures 1 - 2.

Before attempting to use this product, familiarize yourself with all operating features and safety rules.

## AIRGRIP™ VACUUM TECHNOLOGY

This product uses a vacuum base that can adhere to smooth surfaces. Using the vacuum seal prevents wall damage caused by nails or adhesive tape. The vacuum base is used to hold the MultiTASKit™ attachments and will support a weight of up to 15 lbs. Recessed grooves on the base can be used for attaching the end of a chalk line, and side slots are available for holding the end of a tape measure.

## CASE

A zippered fabric case stores and protects the tool and accessories when not in use.

## HELPING HAND ATTACHMENT

Use the helping hand attachment to assist in holding small amounts of weight up to 12 lbs. The hand can be extended up to 3 in. and will rotate 360° horizontally and 35° vertically.

## HOOK-AND-LOOP STRAP

The hook-and-loop strap can be used along with the multi-function base to attach the unit to a variety of irregularly shaped surfaces.

## LASER LEVEL ATTACHMENT

The laser level attachment emits a laser line of up to 30 feet and can be rotated 360°.

## LIGHTING ATTACHMENT

The lighting attachment has three medium-intensity LED lights to provide light in dark work areas. It can be adjusted vertically up to 90° and rotated horizontally 360°.

## MAGNETIC TRAY ATTACHMENT

The magnetic tray attachment can be used for holding screws, nuts, and bolts. It features two holes for holding screwdrivers or other small tools, and has a recessed front edge so tools can lie flat on the surface. The tray can be adjusted 90° vertically and 360° horizontally.

## MULTI-FUNCTION BASE

The multi-function base allows the unit to be used on irregularly shaped walls or objects. It features built-in loops for a hook-and-loop strap and magnetic sides to hold securely to magnetic surfaces. The base also protects the unit when using on a dusty or dirty surface and during storage.

## ROUGH-SURFACE ADAPTOR

The rough-surface adaptor increases the number of surfaces on which the AIRgrip vacuum can be used.

# ASSEMBLY

## UNPACKING

This product has been shipped completely assembled.

- Carefully remove the tool and any accessories from the box. Make sure that all items listed in the packing list are included.
- Inspect the tool carefully to make sure no breakage or damage occurred during shipping.
- Do not discard the packing material until you have carefully inspected and satisfactorily operated the tool.
- If any parts are damaged or missing, please call 1-800-525-2579 for assistance.

## PACKING LIST

Vacuum Base	4 AA Batteries
Multi-function Base	Hook-and-Loop Strap
Laser Level Attachment	Rough Surface Adaptor
Lighting Attachment	Case
Magnetic Tray Attachment	Operator's Manual
Helping Hand Attachment	

### **⚠ WARNING:**

If any parts are missing, do not operate this tool. Please return to the place of purchase or call 1-800-525-2579 for assistance.

### **⚠ WARNING:**

Do not attempt to modify this tool or create accessories not recommended for use with this tool. Any such alteration or modification is misuse and could result in a hazardous condition leading to possible serious personal injury.

**NOTE:** Before initial use, wipe the AIRgrip seal with a damp cloth to remove any residue.

# OPERATION

### **⚠ WARNING:**

Do not allow familiarity with tools to make you careless. Remember that a careless fraction of a second is sufficient to inflict serious injury.

### **⚠ WARNING:**

Do not use any attachments or accessories not recommended by the manufacturer of this tool. The use of attachments or accessories not recommended can result in serious personal injury.

## APPLICATIONS

You may use this tool for the purposes listed below:

- Single-person measuring
- Hanging pictures
- Aligning electrical outlets or ceiling lights
- Holding small screws and tools
- Installing towel bars, curtains, etc.
- Installing chair rail and crown molding
- Laying tile, flooring, or wallpaper
- Holding a chalk line in place
- Temporary lighting under sinks, in closets, and for cars
- Simplifying two-person jobs to one person

## INSTALLING BATTERIES IN VACUUM BASE

See Figure 3.

The battery compartment is located beneath the ridged area of the vacuum base.

### To open:

- Pull the battery cover out to remove.
- Install two AA batteries according to polarity indicators inside the battery compartment.
- Place the battery cover plate back onto the base and secure.

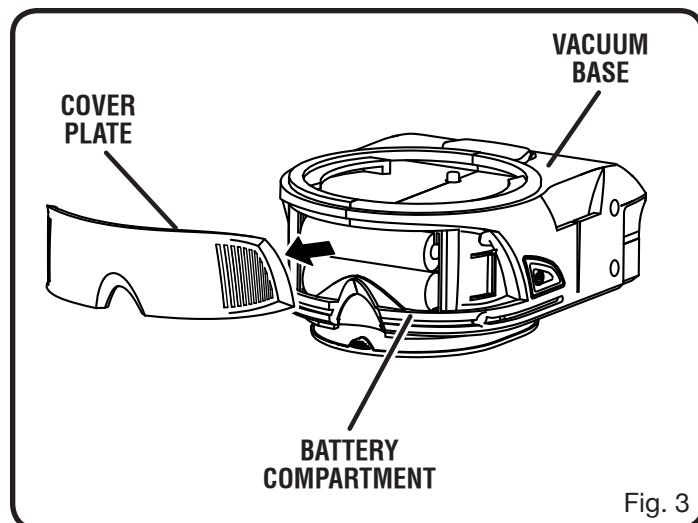



# OPERATION

## TURNING THE VACUUM BASE ON/OFF

See Figure 4.

Press the button located on the side of the vacuum base to turn it **ON** and **OFF**. Always wait for at least 5 seconds between stopping and restarting the unit.

## USING THE AIR-GRIP™ VACUUM BASE

See Figures 5 - 6.

Vacuum grip technology allows the unit to be attached to most smooth surfaces.

**NOTE:** The multi-function base is **not** used when mounting by vacuum grip.

- Place the unit on the surface you want it secured to and push against the surface slightly to engage the seal.
- Continue to hold the unit against the surface while pressing the on/off button.
- Release the unit when you hear a change in motor sound.
- To release the vacuum seal, turn the power to the vacuum base off. For fast release, press the protrusion on the back of the unit.

**NOTE:** Pulling the unit off the wall without releasing the vacuum could damage the tool.

The grooves located in the vacuum base can be used to help hold a tape measure or chalk line when working unassisted.

## ROUGH-SURFACE ADAPTOR

See Figure 7.

By using the rough-surface adaptor, you can use the AIRgrip feature to position the unit on many non-smooth surfaces, including brick and painted cinder block.

**NOTE:** The AIRgrip feature cannot be used with stucco or unpainted cinder block.

- Position the rough-surface adaptor on the surface where you want to secure the vacuum base.

**NOTE:** The dotted lines on the adaptor should be visible.

- Place the unit against the adaptor on the dotted lines, and push in slightly to engage the seal.
- Continue to hold the unit against the surface while pressing the on/off button.
- Release the unit when you hear a change in motor sound.

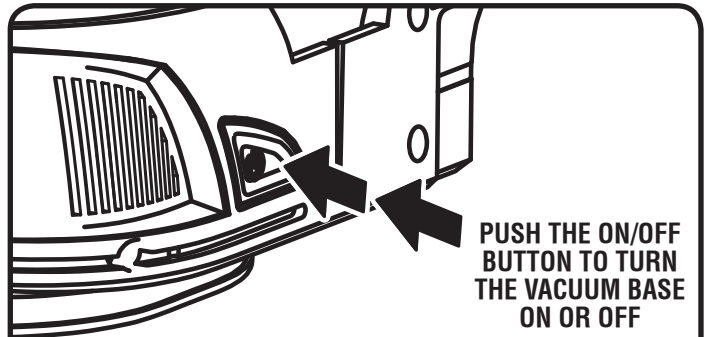

Fig. 4

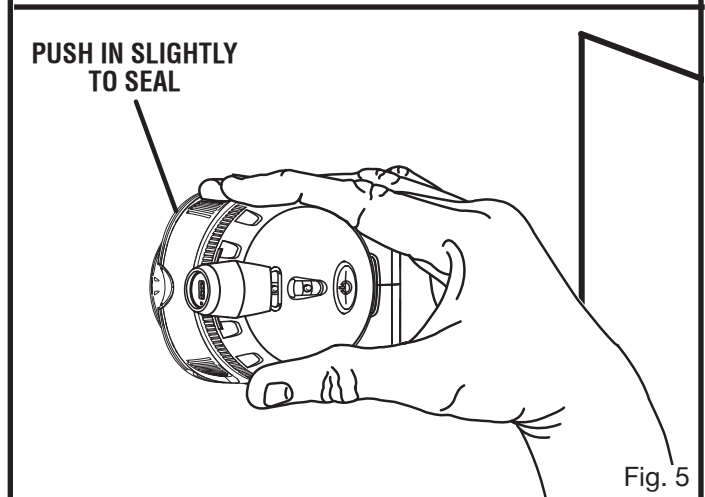

Fig. 5

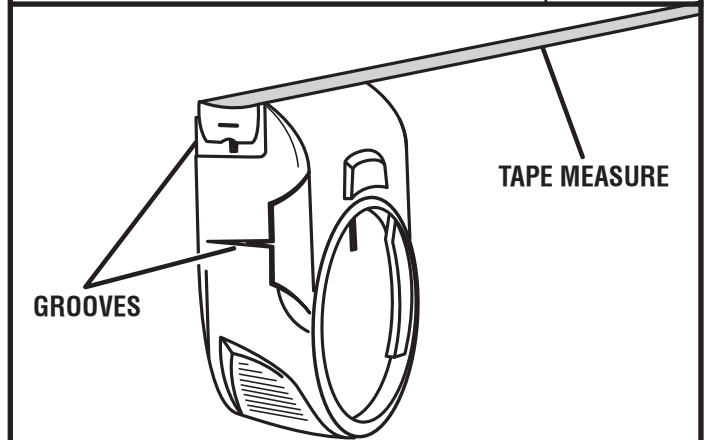

Fig. 6

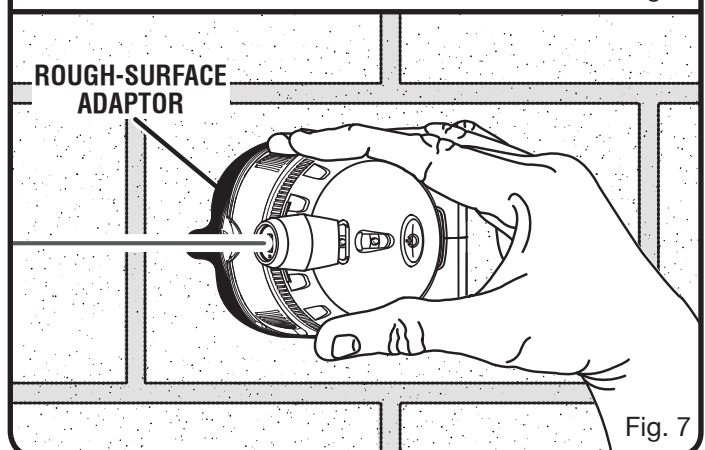

Fig. 7

# OPERATION

## USING THE MULTI-FUNCTION BASE

See Figures 8 - 9.

To use the hook-and-loop strap or magnetic mounts, the multi-function base must be installed. To install the base:

- While holding the vacuum base with the on/off button facing you, align the raised ridge on the multi-function base with the groove on the vacuum base.
- Slide the two completely together.

**NOTE:** If the multi-function base is seated correctly, the vacuum will not operate when the power is turned on.

**HOOK-AND-LOOP STRAP:** The strap can be used to attach the base to irregularly shaped objects such as pipes, 2x4s, 2x6s, or metal grates.

### To install the strap:

- Attach the strap to one side of the multi-function base by threading it through the loop and fastening.
- Position the unit on the surface where you want it mounted.
- Wrap the strap around the object being mounted (pipe, board, etc.).
- Place the loose end of the strap through the remaining loop on the base and secure.

### CAUTION:

Use caution when using the multi-function base. Do not orient the unit in a way that will allow the vacuum base to slide or fall out of the multi-function base.

**MAGNETIC MOUNTS:** The magnetic mounts of the multi-function base allow the unit to be attached securely to magnetically attracted metal surfaces.

## INSTALLING BATTERIES IN THE LASER LEVEL AND LIGHTING ATTACHMENTS

See Figure 10.

The laser level and lighting attachments are powered independently from the vacuum base. Each attachment requires two AA batteries to operate.

### To install batteries:

- Press the battery compartment access button on the laser or lighting attachment to separate top of attachment from attachment base.
- Install batteries according to the polarity indicators in the compartment.
- Reinstall attachment base. When secure, battery access button will click back into place.

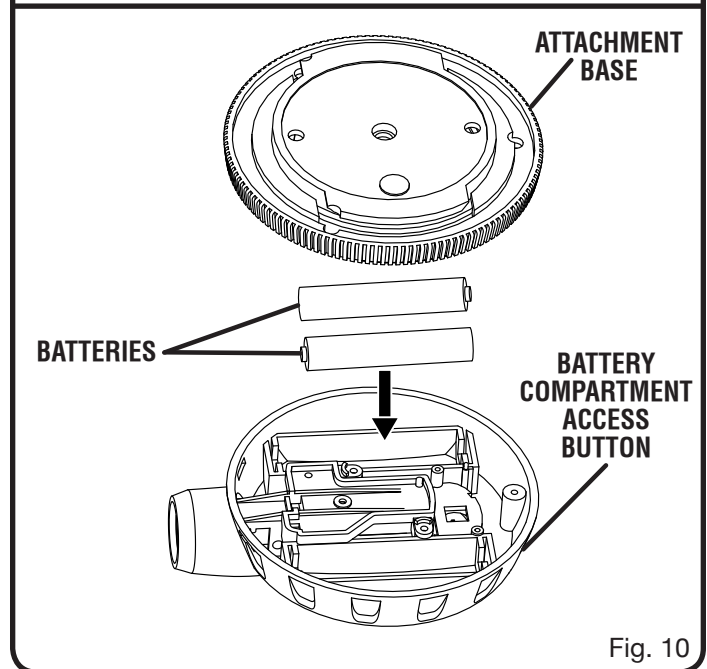
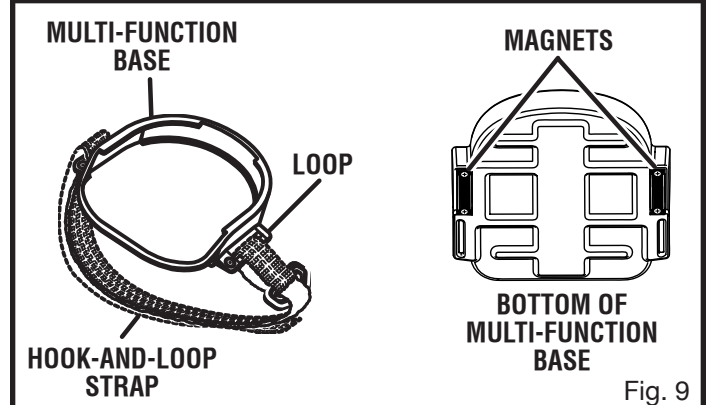
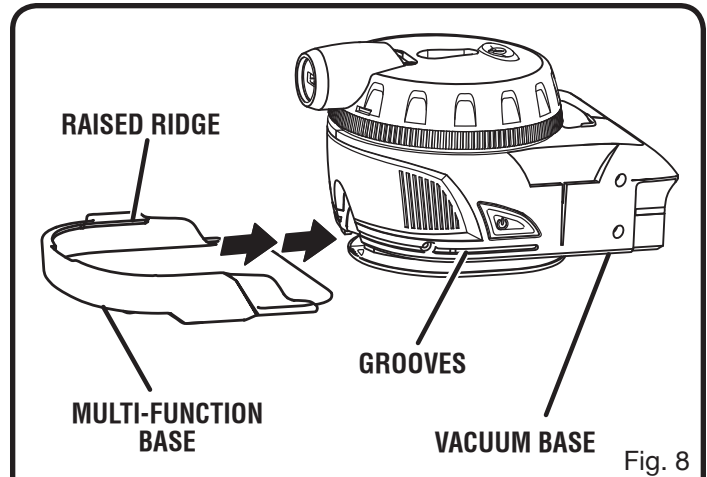

# OPERATION

## REMOVING/INSTALLING ATTACHMENTS

See Figure 11.

To install an attachment on the vacuum base, align the locking tabs on the desired attachment to the openings on the vacuum base so the molded-in arrow is directly centered above the battery door. Seat the attachment on the base and rotate until you hear the attachment click into place.

To remove an attachment from the base, depress the release button on the top of the base, twist the attachment until the locking tabs on the attachment are aligned with the openings in the base, then lift to remove.

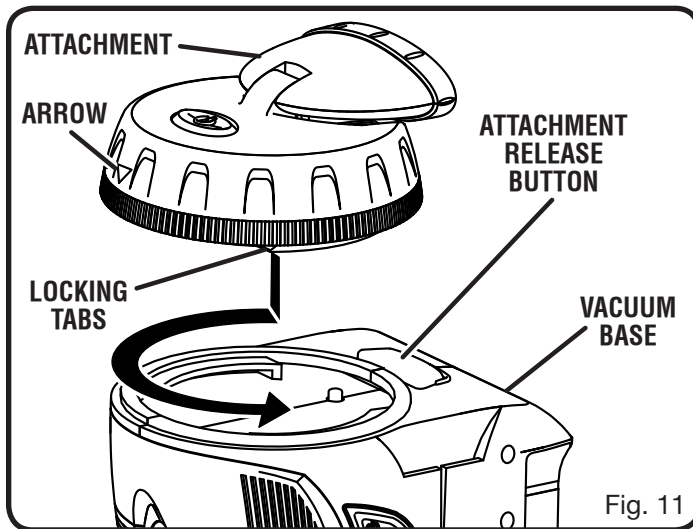

## USING THE LASER LEVEL ATTACHMENT

See Figures 12 - 13.

The laser level attachment will project a straight line across an obstruction or interference. The line can be rotated 360 degrees by turning the laser attachment in a clockwise or counterclockwise direction. Re-level the unit for each wall, adjacent surface, or direction a line is generated towards.

- Place the level in the area where you want the laser line projected.
- If a true horizontal line is desired, level the tool by centering the bubbles inside the vials located on top of the laser attachment.

**NOTE:** To ensure plumb lines, level vial and position the tool directly in front of the work area.

- Press the on/off button located on top of the laser level attachment to turn the laser level on.
- Rotate the laser level attachment to position the laser line where needed.

**NOTE:** Due to construction inaccuracy, walls may not be perfectly straight. This may cause the laser to have slight variances when in the level position.

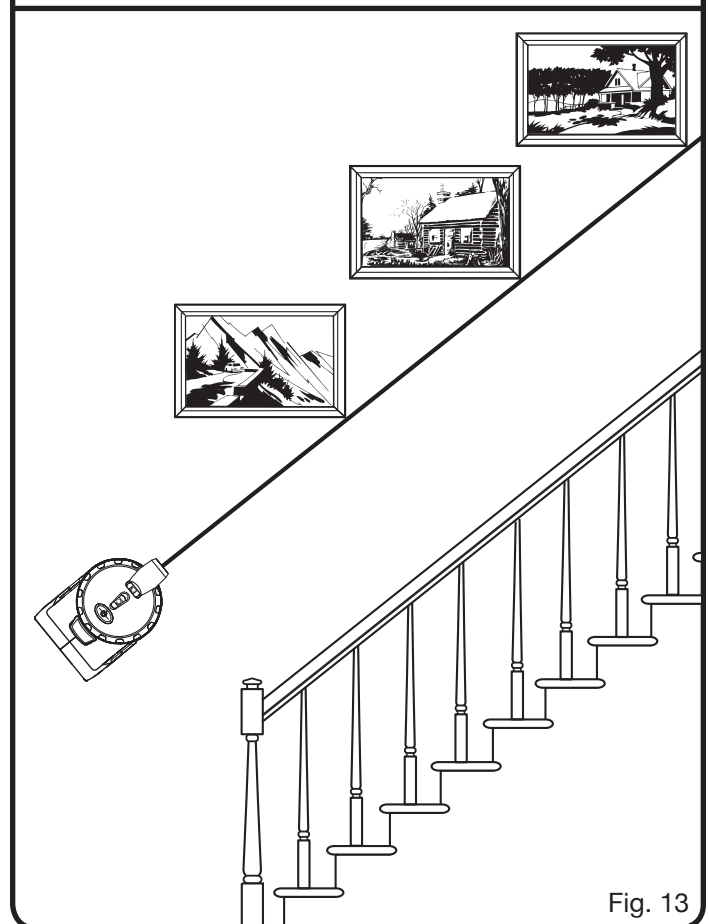
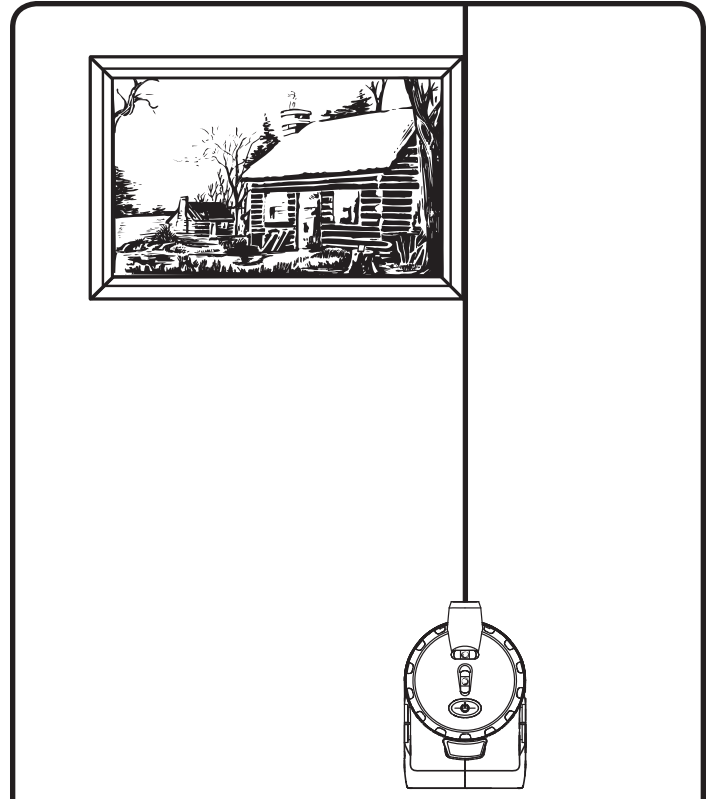

# OPERATION

## USING THE LIGHTING ATTACHMENT

See Figure 14.

The lighting attachment uses three medium-intensity LED lights to provide extra illumination in dark workspaces. The light beam can be adjusted up to 90°, and the lighting attachment can be rotated 360°. Turn the lights on and off by depressing the on/off button located on top of the attachment.

## USING THE MAGNETIC TRAY ATTACHMENT

See Figure 15.

Position the tray in a horizontal or vertical position and tighten the locking knob to secure in place. The magnetic surface will hold small tools and/or nuts, bolts, screws, etc. The small holes on the tray can be used to hold screwdrivers or other cylindrical tools.

## USING THE HELPING HAND ATTACHMENT

See Figure 16.

The helping hand attachment will support a workpiece of up to 12 lbs. The angle of the helping hand can be adjusted up to 35° and is secured in place using the locking knob. The length of the arm can be adjusted up to 3 in. by loosening the center screw, sliding the arm up or down as desired, then retightening the center screw to secure.

### **WARNING:**

Do not use the helping hand to support anything weighing more than 12 lbs. Failure to heed this warning could cause serious personal injury.

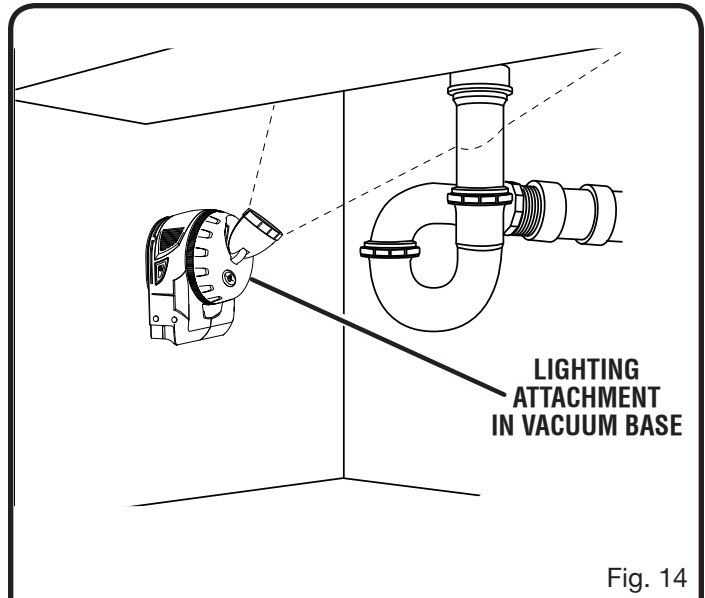

Fig. 14

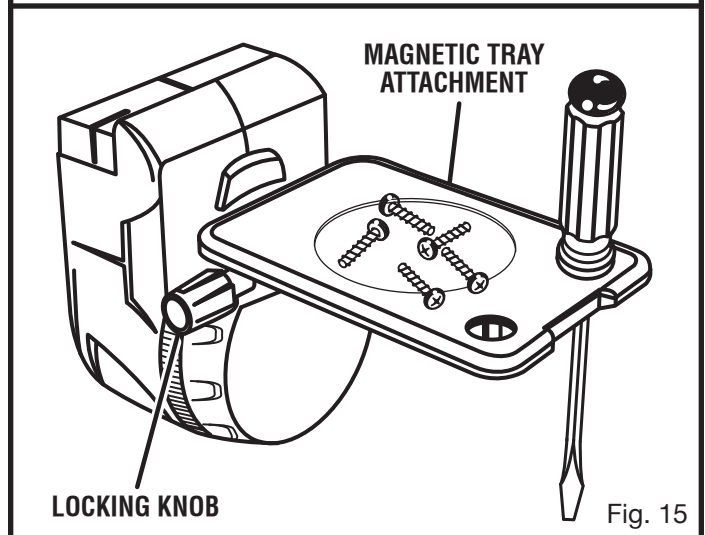

Fig. 15

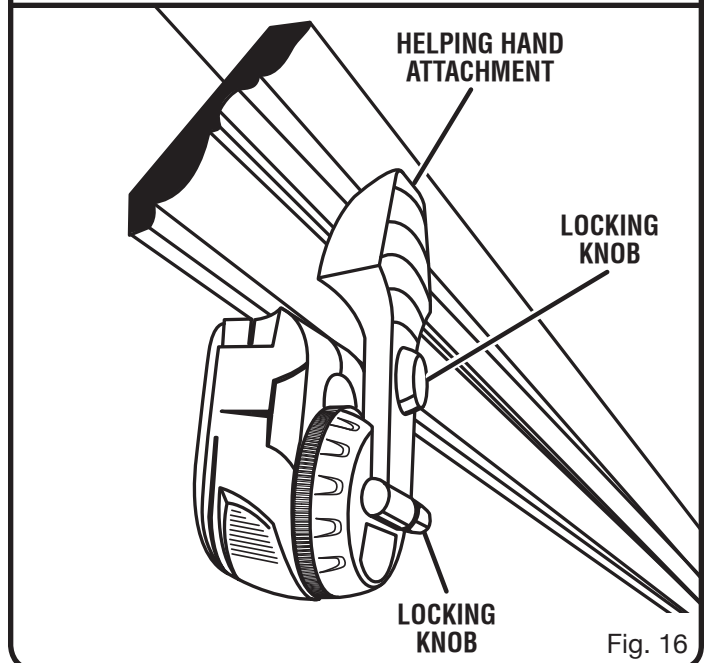

Fig. 16

# MAINTENANCE

## **WARNING:**

To avoid serious personal injury, always remove the batteries from the tool when cleaning or performing any maintenance.

## GENERAL MAINTENANCE

- Before initial use, wipe AIRgrip vacuum base with a damp cloth to remove any residue.
- Store the unit indoors.
- When not in use, the vacuum base and attachments should be kept in the protective case.
- Keep the unit free of dust and liquids. Use a damp cloth and mild soap to clean the outside casing. Avoid using solvents when cleaning plastic parts. Most plastics are susceptible to damage from various types of commercial solvents and may be damaged by their use.

- To clean the laser lens and lighting lens, if needed, use ONLY a soft cloth or cotton swab moistened with glass cleaner.
- Check the batteries regularly to avoid deterioration. Remove the batteries from the vacuum base, laser attachment, and/or lighting attachment, if you will not be using them for an extended time.
- Do not disassemble the laser level attachment. This could cause exposure to hazardous laser radiation.
- Do not attempt to change any part of the laser lens.

## **WARNING:**

Do not at any time let brake fluids, gasoline, petroleum-based products, penetrating oils, etc., come in contact with plastic parts. Chemicals can damage, weaken, or destroy plastic, which may result in serious personal injury.

---

ALWAYS BE AWARE of the location where the laser light is emitted when using the laser level attachment. ALWAYS MAKE SURE that any bystanders in the vicinity of use are made aware of the dangers of looking directly into the laser beam.



**DANGER**

**LASER RADIATION-**  
**AVOID DIRECT EYE EXPOSURE**

---

 **MAXIMUM OUTPUT < 5mW**  
**WAVELENGTH 630-670 nm**  
**Class IIIa LASER PRODUCT**

This product complies with 21 CFR 1040.10 and 1040.11

# TROUBLESHOOTING

Problem	Possible Cause	Solution
Vacuum not running	Batteries are low Power is turned off	Replace batteries. Press on/off button.
Laser line projection is weak	Batteries are low	Replace batteries.
Laser line is hard to see	Light in area is too bright	Dim light in the work area or use laser-enhancing glasses.
Light is not working	Power is not "on" Batteries are low	Press the on/off button. Replace batteries.
Laser line is not level	Leveling bubbles not properly aligned  Level is mounted on base that is not level	Make sure bubbles are centered in vials.  Make sure bubbles are centered in vials after installing multi-function base onto vacuum base.
Light is dim	Batteries are low	Replace batteries.
Magnetic tray isn't holding items	Items are not placed on the magnet	Put items in the center of the tray where magnets are located.
Magnetic tray is loose or won't stay in position	Handle isn't tight	Rotate the height adjustment screw clockwise to tighten.
Magnetic tray is too tight/won't move	Handle is tight	Rotate the height adjustment screw counterclockwise to loosen.
Helping hand is loose	Screws not tight	Rotate the locking knob clockwise to secure in position.
Vacuum base won't stick to wall	Surface is incompatible for vacuum	Use rough-surface adaptor on stucco and textured surfaces.





# OPERATOR'S MANUAL

## AIRgrip MultiTASKit™

**EMM0001**

- **SERVICE**

This product has no serviceable parts. If unit fails due to normal wear and tear within two years of purchase, return with original receipt for a replacement unit at no charge. Please call 1-800-525-2579 for the nearest Ryobi Authorized Service Center. You can also check our web site at [www.ryobitools.com](http://www.ryobitools.com) for a complete list of Authorized Service Centers.

- **MODEL NO.**

The model number of this tool will be found on a label attached to the top of the laser head. Please visit our website at [www.ryobitools.com](http://www.ryobitools.com) to register this product.

- **HOW TO ORDER REPLACEMENT PARTS**

When ordering replacement parts, always give the following information:

- MODEL NUMBER EMM0001

### **RYOBI TECHNOLOGIES, INC.**

1428 Pearman Dairy Road, Anderson, SC 29625  
Post Office Box 1207, Anderson, SC 29622-1207

Phone 1-800-525-2579

[www.ryobitools.com](http://www.ryobitools.com)