

RYOBI
HAMMER DRILL
MODEL NO. D550H
REPAIR SHEET

RYOBI HAMMER DRILL – MODEL NUMBER D550H

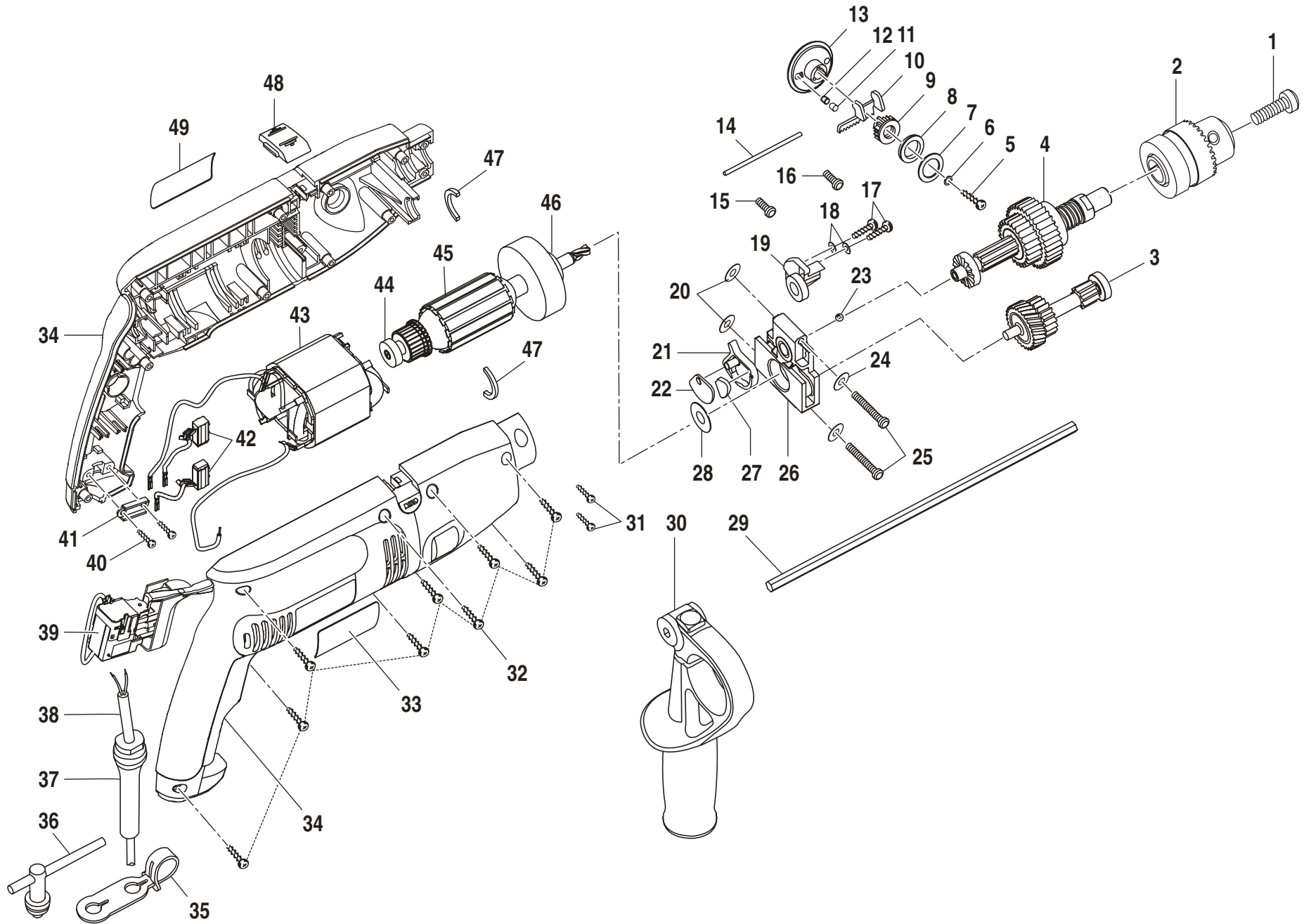

RYOBI HAMMER DRILL – MODEL NUMBER D550H

The model number will be found on a plate attached to the motor housing. Always mention the model number in all correspondence regarding your **HAMMER DRILL** or when ordering repair parts.

PARTS LIST

KEY NO.	PART NUMBER	DESCRIPTION	QTY.	KEY NO.	PART NUMBER	DESCRIPTION	QTY.
1	6613402	* SCREW (M6 X 27 mm)	1	28	900722002	OIL SEAL	1
2	690090003	CHUCK	1	29	6341203	GUIDE ROD GAUGE	1
3	984723001	GEAR & SPINDLE ASSEMBLY	1	30	3018808	AUXILIARY HANDLE ASSEMBLY	1
4	984722001	OUTPUT SPINDLE/GEAR ASSEMBLY	1	31	6620805	* SCREW (M4 X 16 mm)	2
5	6620310	* SCREW (M3 X 14 mm)	1	32	660208013	* SCREW (M4 X 20 mm)	9
6	630636001	SPRING WASHER	1	33	940214045	DATA PLATE	1
7	690497001	WASHER	1	34	984717001	HOUSING ASSEMBLY	1
8	900701001	FELT WASHER	1	35	5678001	CHUCK KEY STRAP	1
9	610305001	SPEED ADJUST GEAR	1	36	6917601	CHUCK KEY	1
10	690441001	SLIPPING RACK	1	37	5927402	BEND RELIEF	1
11	690541001	COPPER CAP	1	38	730202006	POWER CORD	1
12	690542001	SPRING	1	39	984719001	SWITCH ASSEMBLY	1
13	400234001	SPEED BUTTON	1	40	6620801	* SCREW (M4 X 12 mm)	2
14	690457001	STEEL TRACK ROD	1	41	6906901	CORD CLAMP	1
15	660290004	* SCREW (M3 X 5 mm)	1	42	984720001	BRUSH ASSEMBLY	2
16	660099001	* SCREW (M2.6 X 8 mm)	1	43	740399001	FIELD ASSEMBLY	1
17	660206018	* SCREW (M3.5 X 15 mm)	2	44	6899901	BEARING (607ZZ)	1
18	680379001	SPRING WASHER	2	45	984718001	ARMATURE ASSEMBLY (INCLUDES KEY NOS. 44 & 46)	1
19	690942003	ARMATURE SHAFT SUPPORT	1	46	6906201	BEARING (608LLB)	1
20	690885001	WASHER	2	47	900694001	FELT SEAL	1
21	590233001	HAMMER ADJUST LEVER	1	48	590296001	MODE SELECTOR	1
22	690477001	HAMMER ADJUST PLATE	1	49	940213032	LOGO PLATE	1
23	6721901	STEEL BALL	1		300636097	CARRYING CASE (NOT SHOWN)	
24	6703001	SPRING WASHER	2		983000-129	OPERATOR'S MANUAL	
25	660237005	* SCREW (M4 X 37 mm)	2		983000-129R	REPAIR SHEET (REV:00)	
26	984721001	BEARING PLATE ASSEMBLY	1		12-16-04		
27	690443001	DRILL MODE INSERT	1				

WARNING: Improper repair of a double insulated tool can result in damage to the double insulation system possibly causing electrical shock or electrocution. Any repairs requiring disassembly of your tool requires safety testing and should only be performed by a Ryobi Authorized Service Center. For the service center nearest you call 1-800-525-2579.

* Standard Hardware Item – May Be Purchased Locally