

**RYOBI 3/8 in. (10 mm)  
CLUTCH DRIVER  
MODEL NO. D45CK  
REPAIR SHEET**

**RYOBI 3/8 in. (10 mm) DRILL-DRIVER – MODEL NO. D45CK**

The model number will be found on a plate attached to the motor housing. Always mention the model number in all correspondence regarding your **RYOBI 3/8 in. DRILL-DRIVER** or when ordering parts.

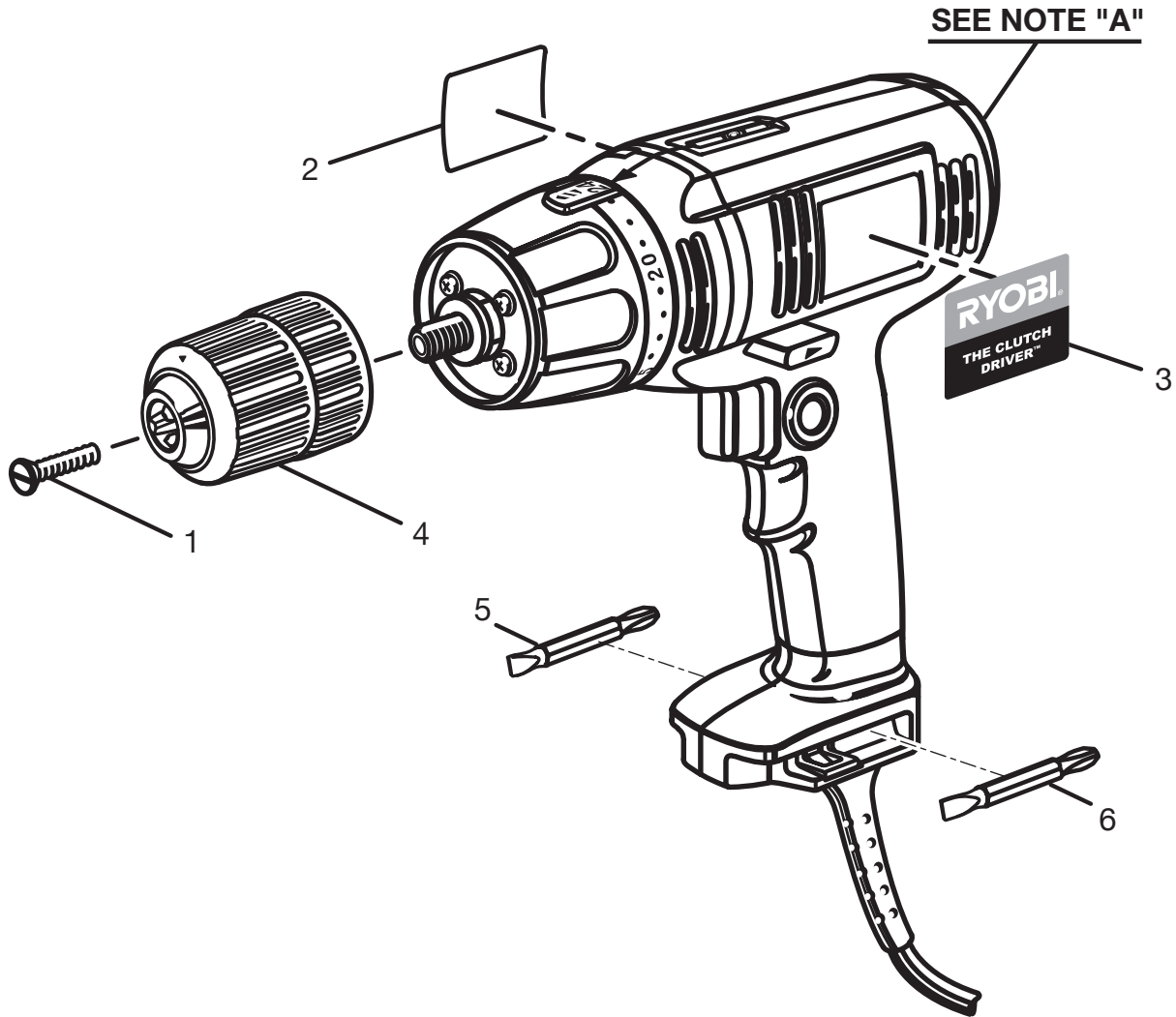

**PARTS LIST**

KEY NO.	PART NUMBER	DESCRIPTION	QTY.
1	6612003	CHUCK SCREW.....	1
2	940214077	DATA PLATE .....	1
3	940185030	LOGO PLATE .....	1
4	690032011	3/8 in. (10 mm) CHUCK .....	1
5	971032000	BIT .....	1
6	971031000	BIT .....	1
7	982798001	CARRY CASE (NOT SHOWN).....	1

**NOTE: "A"– THE ASSEMBLY SHOWN REPRESENTS AN IMPORTANT PART OF THE DOUBLE INSULATED SYSTEM. TO AVOID THE POSSIBILITY OF ALTERATION OR DAMAGE TO THE SYSTEM, SERVICE SHOULD BE PERFORMED BY YOUR NEAREST AUTHORIZED SERVICE CENTER.**

**RYOBI 3/8 in. (10 mm) DRILL- DRIVER – MODEL NO. D45CK**

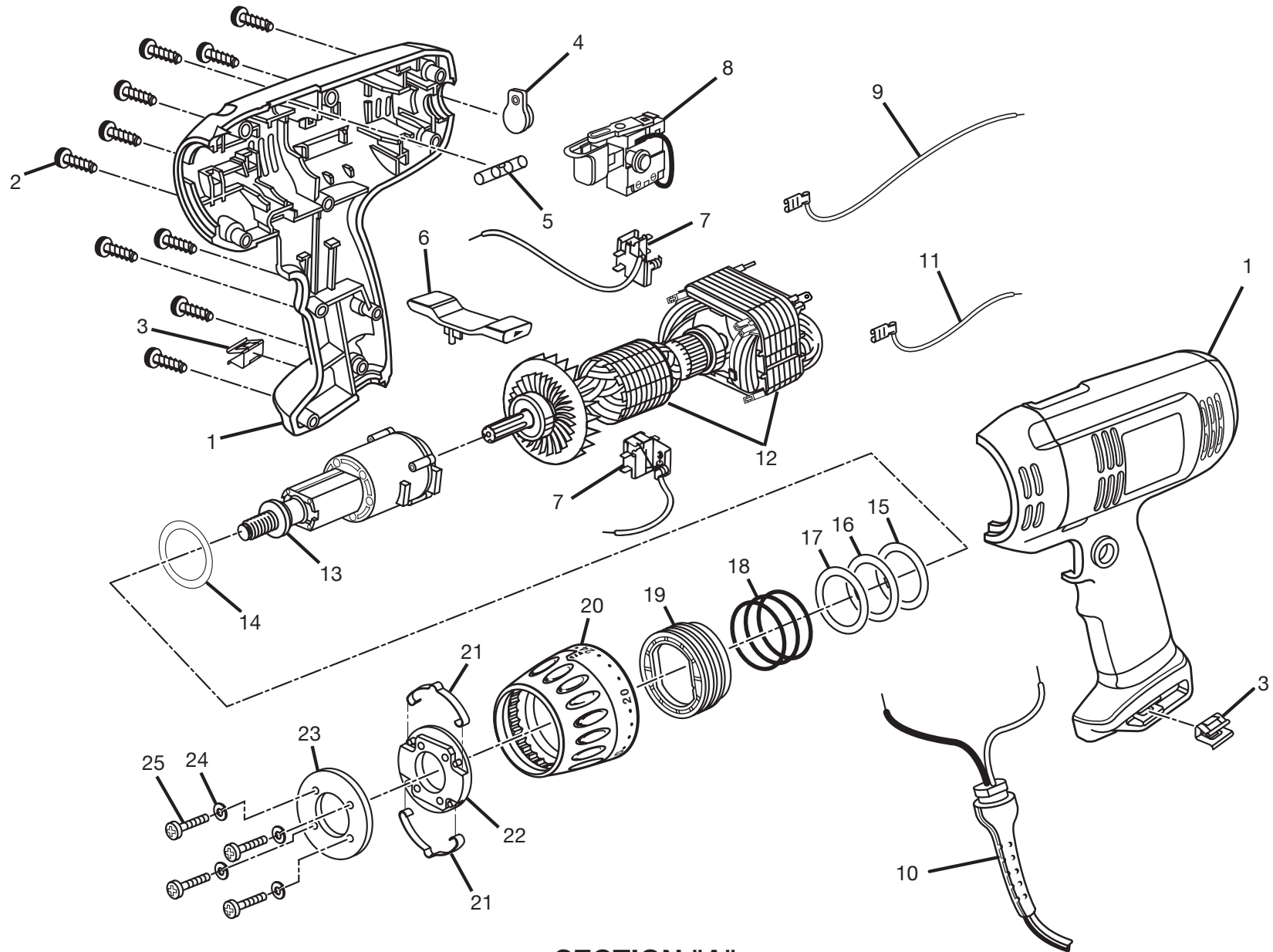

**SECTION "A"**

**SECTION "A" REPRESENTS AN IMPORTANT PART OF THE DOUBLE INSULATED SYSTEM OF THIS TOOL. ANY REPAIR TO THIS TOOL REQUIRES DIELECTRIC TESTING TO INSURE CUSTOMER SAFETY AND TO COMPLY WITH COMPANY REQUIREMENTS.**

## RYOBI 3/8 in. (10 mm) DRILL- DRIVER – MODEL NO. D45CK

The model number will be found on a plate attached to the motor housing. Always mention the model number in all correspondence regarding your **DRILL-DRIVER** or when ordering repair parts.

### PARTS LIST

KEY NO.	PART NUMBER	DESCRIPTION	QTY.
1	982839-001	HOUSING ASSEMBLY .....	1
2	981901-001	* SCREW (M4 X 16 mm) .....	10
3	6320601	BIT CLIP .....	2
4	3048001	REAR LEVEL.....	1
5	3000901	TOP LEVEL.....	1
6	5422901	FORWARD-REVERSE SELECTOR.....	1
7	2906903	BRUSH ASSEMBLY .....	2
8	7619701	SWITCH.....	1
9	2908511	WHITE LEAD (100 mm) .....	1
10	7320201	POWER CORD .....	1
11	2908510	WHITE LEAD (250 mm) .....	1
12	2909424	MOTOR ASSEMBLY (INCLUDES ARMATURE AND FIELD).....	1
13	220017039	GEAR BOX ASSEMBLY.....	1
14	6759003	CLUTCH WASHER (0.50 mm).....	1
15	6897002	WASHER (0.20 mm) SHIM AS NEEDED.....	1
16	6897005	WASHER (0.10 mm) SHIM AS NEEDED.....	1
17	6897003	WASHER (0.15 mm) SHIM AS NEEDED.....	1
18	6843401	SPRING .....	1
19	5437201	SLEEVE .....	1
20	300155029	CLUTCH CAP ASSEMBLY .....	1
21	6399201	DETENT CLIP .....	2
22	5434601	SPRING HOLDER.....	1
23	6359801	MOUNTING PLATE.....	1
24	6702801	* LOCK WASHER (M3).....	4
25	6621120	* SCREW (M3 X 15 mm) .....	4
	983000-473	OPERATOR'S MANUAL	
	983000-473R	REPAIR SHEET	
	04-15-04		

\* Standard Hardware Item – May Be Purchased Locally

RYOBI 3/8 in. (10 mm) DRILL- DRIVER – MODEL NO. D45CK

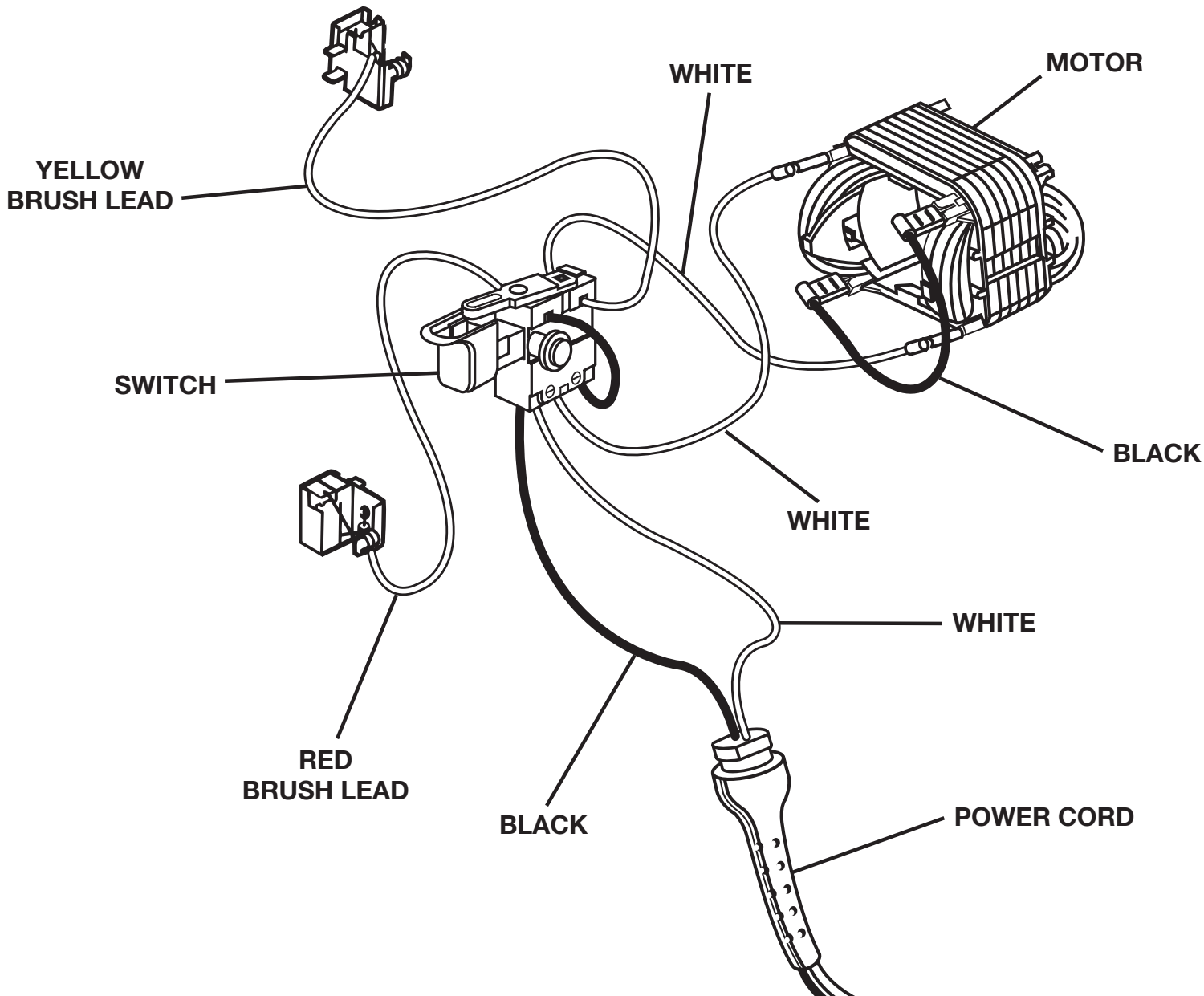

**WIRING DIAGRAM**