

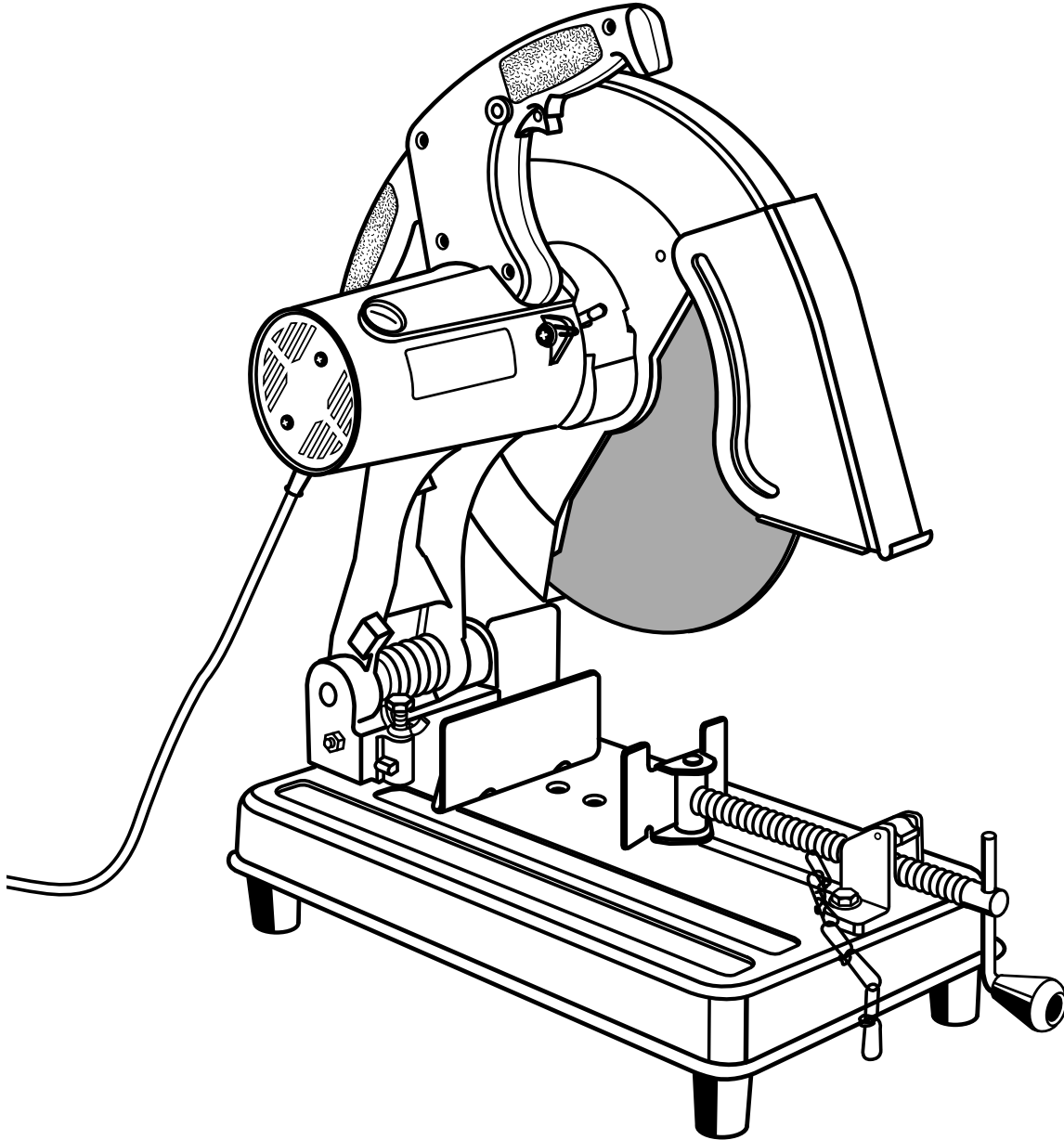

OPERATOR'S MANUAL

14 in. Abrasive Cut-Off Machine

C358



Your cut-off machine has been engineered and manufactured to Ryobi's high standard for dependability, ease of operation, and operator safety. When properly cared for, it will give you years of rugged, trouble-free performance.

⚠ WARNING: To reduce the risk of injury, the user must read and understand the operator's manual before using this product.

Thank you for buying a Ryobi product.

SAVE THIS MANUAL FOR FUTURE REFERENCE

TABLE OF CONTENTS

■ Introduction	2
■ General Safety Rules	3-4
■ Specific Safety Rules	4-5
■ Symbols	6-7
■ Electrical	8
■ Features	9-10
■ Loose Parts	11
■ Assembly	11-15
■ Operation	15-17
■ Maintenance	18
■ Troubleshooting	19
■ Parts Ordering / Service	20

INTRODUCTION

This tool has many features for making its use more pleasant and enjoyable. Safety, performance, and dependability have been given top priority in the design of this product making it easy to maintain and operate.

IMPORTANT INFORMATION ON THE USE OF CUT-OFF WHEELS AND ANSI B7.1 can be obtained by writing to:

**GRINDING WHEEL INSTITUTE
30200 Detroit Road
Cleveland, OH 44145-1967**

GENERAL SAFETY RULES



WARNING:

Read and understand all instructions. Failure to follow all instructions listed below, may result in electric shock, fire and/or serious personal injury.

READ ALL INSTRUCTIONS

- **KNOW YOUR POWER TOOL.** Read the operator's manual carefully. Learn the cut-off machine's applications and limitations as well as the specific potential hazards related to this tool.
- **GUARD AGAINST ELECTRICAL SHOCK BY PREVENTING BODY CONTACT WITH GROUNDED SURFACES.** For example: pipes, radiators, ranges, refrigerator enclosures.
- **KEEP GUARDS IN PLACE** and in working order. Never operate the tool with any guard or cover removed. Make sure all guards are operating properly before each use.
- **REMOVE ADJUSTING KEYS AND WRENCHES.** Form habit of checking to see that keys and adjusting wrenches are removed from tool before turning it on.
- **KEEP WORK AREA CLEAN.** Cluttered areas and benches invite accidents. **DO NOT** leave tools or material on the machine while it is in operation.
- **AVOID DANGEROUS ENVIRONMENT.** Don't use power tools in damp or wet locations or expose to rain. Keep work area well lit.
- **KEEP CHILDREN AND VISITORS AWAY.** All visitors should wear safety glasses and be kept a safe distance from work area. Do not let visitors contact tool or extension cord while operating.
- **MAKE WORKSHOP CHILDPROOF** with padlocks or master switches, or by removing starter keys.
- **DON'T FORCE TOOL.** It will do the job better and safer at the feed rate for which it was designed.
- **USE RIGHT TOOL.** Don't force tool or attachment to do a job it was not designed for. Don't use it for a purpose not intended.
- **MAKE SURE YOUR EXTENSION CORD IS IN GOOD CONDITION.** When using an extension cord, be sure to use one heavy enough to carry the current your product will draw. An undersized cord will cause a drop in line voltage resulting in loss of power and overheating. A wire gage size (A.W.G.) of at least **14** is recommended for an extension cord **25** feet or less in length. If in doubt, use the next heavier gage. The smaller the gage number, the heavier the cord.
- **DRESS PROPERLY.** Do not wear loose clothing, gloves, neckties, or jewelry. They can get caught and draw you into moving parts. Rubber gloves and nonskid footwear are recommended when working outdoors. Also wear protective hair covering to contain long hair.
- **ALWAYS WEAR SAFETY GLASSES WITH SIDE SHIELDS.** Everyday eyeglasses have only impact-resistant lenses; they are **NOT** safety glasses.
- **SECURE WORK.** Use clamps or a vise to hold work when practical. It's safer than using your hand and frees both hands to operate tool.
- **DON'T OVERREACH.** Keep proper footing and balance at all times.
- **MAINTAIN TOOLS WITH CARE.** Keep tools sharp and clean for better and safer performance. Follow instructions for lubricating and changing accessories.
- **DISCONNECT TOOLS.** When not in use, before servicing, or when changing attachments, wheels, bits, cutters, etc., all tools should be disconnected.
- **AVOID ACCIDENTAL STARTING.** Be sure switch is off when plugging in.
- **USE RECOMMENDED ACCESSORIES.** The use of improper accessories may cause risk of injury.
- **NEVER STAND ON TOOL.** Serious injury could occur if the tool is tipped or if the cutting wheel is unintentionally contacted.
- **CHECK DAMAGED PARTS.** Before further use of the tool, a guard or other part that is damaged should be carefully checked to determine that it will operate properly and perform its intended function. Check for alignment of moving parts, binding of moving parts, breakage of parts, mounting and any other conditions that may affect its operation. A guard or other part that is damaged must be properly repaired or replaced by an authorized service center to avoid risk of personal injury.
- **NEVER LEAVE TOOL RUNNING UNATTENDED. TURN POWER OFF.** Don't leave tool until it comes to a complete stop.
- **PROTECT YOUR LUNGS.** Wear a face or dust mask if the cutting operation is dusty.
- **PROTECT YOUR HEARING.** Wear hearing protection during extended periods of operation.
- **DON'T ABUSE CORD.** Never yank cord to disconnect from receptacle. Keep cord from heat, oil, and sharp edges.
- **USE OUTDOOR EXTENSION CORDS.** When tool is used outdoors, use only extension cords with approved ground connection that are intended for use outdoors and so marked.
- **WHEELS COAST AFTER TURN OFF.**

GENERAL SAFETY RULES

- **NEVER USE IN AN EXPLOSIVE ATMOSPHERE.** Normal sparking of the motor could ignite fumes.
- **INSPECT TOOL CORDS PERIODICALLY.** If damaged, have repaired by a qualified service technician at an authorized service facility. The conductor with insulation having an outer surface that is green with or without yellow stripes is the equipment-grounding conductor. If repair or replacement of the electric cord or plug is necessary, do not connect the equipment-grounding conductor to a live terminal. Repair or replace a damaged or worn cord immediately. Stay constantly aware of cord location and keep it well away from the rotating wheel.
- **INSPECT EXTENSION CORDS PERIODICALLY** and replace if damaged.
- **KEEP TOOL DRY, CLEAN, AND FREE FROM OIL AND GREASE.** Always use a clean cloth when cleaning. Never use brake fluids, gasoline, petroleum-based products, or any solvents to clean tool.
- **STAY ALERT AND EXERCISE CONTROL.** Watch what you are doing and use common sense. Do not operate tool when you are tired. Do not rush.
- **DO NOT USE TOOL IF SWITCH DOES NOT TURN IT ON AND OFF.** Have defective switches replaced by an authorized service center.

SPECIFIC SAFETY RULES

- **USE ONLY CORRECT WHEELS.** Do not use wheels with incorrect size holes. Never use wheel washers or wheel screws that are defective or incorrect. The maximum wheel capacity of your cut-off machine is 14 in.
- **DO NOT REMOVE THE MACHINE'S WHEEL GUARDS.** Never operate the machine with any guard or cover removed. Make sure all guards are operating properly before each use.
- **KEEP HANDS AWAY FROM CUTTING AREA.** Keep hands away from wheel. Do not reach underneath work or around or under the wheel while the wheel is rotating. Do not attempt to remove cut material while wheel is moving.
- **ALWAYS SUPPORT LONG MATERIAL.** To minimize risk of tipping machine, always support long material.
- **BEFORE MAKING A CUT, BE SURE ALL ADJUSTMENTS ARE SECURE.**
- **ALWAYS USE THE VISE CLAMP** to secure the material.
- **NEVER TOUCH WHEEL** or other moving parts during use.
- **NEVER START THE CUT-OFF MACHINE WHEN THE WHEEL IS IN CONTACT WITH THE MATERIAL.**
- **NEVER** cut more than one piece of material at a time. **DO NOT STACK** more than one piece of material on the machine base at a time.
- **NEVER PERFORM ANY OPERATION "FREEHAND".** Always secure the material to be cut in the vise.
- **NEVER** hand hold a piece of material. Material will become very hot while being cut.
- **NEVER** reach behind, under, or within three inches of the wheel and its cutting path with your hands and fingers for any reason.
- **NEVER** reach to pick up a piece of material, a piece of scrap, or anything else that is in or near the cutting path of the wheel.
- **AVOID AWKWARD OPERATIONS AND HAND POSITIONS** where a sudden slip could cause your hand to move into the wheel. **ALWAYS** make sure you have good balance.
- **NEVER** stand or have any part of your body in line with the path of the wheel.
- **ALWAYS** release the power switch and allow the wheel to stop rotating before raising wheel guard or removing material.
- **DO NOT TURN THE MOTOR SWITCH ON AND OFF RAPIDLY.** This could cause the wheel to loosen and could create a hazard. Should this ever occur, stand clear and allow the wheel to come to a complete stop. Disconnect your cut-off machine from the power supply and securely retighten the wheel arbor bolt after checking the wheel for damage.
- **WHEN SERVICING USE ONLY IDENTICAL RIDGID REPLACEMENT PARTS.** Use of any other parts may create a hazard or cause product damage.
- **NEVER** leave the cut-off machine unattended while connected to a power source.
- **IF ANY PART OF THIS CUT-OFF MACHINE IS MISSING** or should break, bend, or fail in any way, or should any electrical component fail to perform properly, shut off the power switch, remove the machine plug from the power source and have damaged, missing, or failed parts replaced before resuming operation.
- **MAKE SURE THE CUT-OFF WHEEL IS SECURELY MOUNTED** as described in the operating instructions before connecting the tool to a power supply. Do not tighten wheel excessively, since this can cause cracks.
- **CHECK THE WHEEL FOR FISSURES AND CRACKS,** and test for normal operation prior to use.
- **ONLY USE A CUT-OFF WHEEL RATED FOR 3900 RPM OR GREATER** and manufactured in compliance with ANSI B7.1. Always store wheels in a dry place with little temperature variation.

SPECIFIC SAFETY RULES

- **ALWAYS EASE THE ABRASIVE WHEEL AGAINST THE MATERIAL** when starting to cut. A harsh impact can break the wheel.
- **BEFORE CUTTING** press the trigger switch and allow the cut-off wheel to reach full speed.
- **MAKE SURE THE WORK AREA HAS AMPLE LIGHTING** to see the work and that no obstructions will interfere with safe operation **BEFORE** performing any work using your cut-off machine.
- **USE ONLY FLANGES** furnished with this cut-off machine.
- **DO NOT OVERTIGHTEN THE WHEEL NUT.** Excessive tightening can cause the wheel to crack during operation.
- **FREQUENTLY** clean dust from beneath the cut-off machine.
- **RISK OF FIRE OR EXPLOSION.** This product has parts such as snap switches, receptacles, and the like, which tend to produce arcs or sparks. Therefore, when located in a garage, the machine should be 18 in. above the floor and located in a separate room.
- **DO NOT OPERATE THIS TOOL WHILE UNDER THE INFLUENCE OF DRUGS, ALCOHOL, OR ANY MEDICATION.**
- **ALWAYS STAY ALERT!** Do not allow familiarity (gained from frequent use of your cut-off machine) to cause a careless mistake. **ALWAYS REMEMBER** that a careless fraction of a second is sufficient to inflict severe injury.
- **REPLACE A CRACKED WHEEL IMMEDIATELY.**
- **SAVE THESE INSTRUCTIONS.** Refer to them frequently and use them to instruct other users. If you loan someone this tool, loan them these instructions also.

WARNING:







Some dust created by power sanding, sawing, grinding, drilling, and other construction activities contains chemicals known to cause cancer, birth defects or other reproductive harm. Some examples of these chemicals are:

- lead from lead-based paints,
- crystalline silica from bricks and cement and other masonry products, and
- arsenic and chromium from chemically-treated lumber.

Your risk from these exposures varies, depending on how often you do this type of work. To reduce your exposure to these chemicals: work in a well ventilated area, and work with approved safety equipment, such as those dust masks that are specially designed to filter out microscopic particles.



SYMBOLS

Some of the following symbols may be used on this tool. Please study them and learn their meaning. Proper interpretation of these symbols will allow you to operate the tool better and safer.

SYMBOL	NAME	DESIGNATION/EXPLANATION
V	Volts	Voltage
A	Amperes	Current
Hz	Hertz	Frequency (cycles per second)
W	Watt	Power
min	Minutes	Time
~	Alternating Current	Type of current
≡	Direct Current	Type or a characteristic of current
n_0	No Load Speed	Rotational speed, at no load
	Class II Construction	Double-insulated construction
.../min	Per Minute	Revolutions, strokes, surface speed, orbits etc., per minute
	Wet Conditions Alert	Do not expose to rain or use in damp locations.
	Read The Operator's Manual	To reduce the risk of injury, user must read and understand operator's manual before using this product.
	Eye Protection	Always wear safety goggles, safety glasses with side shields, or a full face shield when operating this product.
	Safety Alert	Precautions that involve your safety.
	No Hands Symbol	Failure to keep your hands away from the wheel will result in serious personal injury.
	Hot Surface	To reduce the risk of injury or damage, avoid contact with any hot surface.

SYMBOLS

The following signal words and meanings are intended to explain the levels of risk associated with this product.

SYMBOL	SIGNAL	MEANING
	DANGER:	Indicates an imminently hazardous situation, which, if not avoided, will result in death or serious injury.
	WARNING:	Indicates a potentially hazardous situation, which, if not avoided, could result in death or serious injury.
	CAUTION:	Indicates a potentially hazardous situation, which, if not avoided, may result in minor or moderate injury.
	CAUTION:	(Without Safety Alert Symbol) Indicates a situation that may result in property damage.

SERVICE

Servicing requires extreme care and knowledge and should be performed only by a qualified service technician. For service we suggest you return the product to your nearest **AUTHORIZED SERVICE CENTER** for repair. When servicing, use only identical replacement parts.

WARNING:

To avoid serious personal injury, do not attempt to use this product until you read thoroughly and understand completely the operator's manual. Save this operator's manual and review frequently for continuing safe operation and instructing others who may use this product.

WARNING:



The operation of any power tool can result in foreign objects being thrown into your eyes, which can result in severe eye damage. Before beginning power tool operation, always wear safety goggles, safety glasses with side shields, or a full face shield when needed. We recommend Wide Vision Safety Mask for use over eye glasses or standard safety glasses with side shields. Always use eye protection which is marked to comply with ANSI Z87.1.

SAVE THESE INSTRUCTIONS

ELECTRICAL

EXTENSION CORDS

Use only 3-wire extension cords that have 3-prong grounding plugs and 3-pole receptacles that accept the tool's plug. When using a power tool at a considerable distance from the power source, use an extension cord heavy enough to carry the current that the tool will draw. An undersized extension cord will cause a drop in line voltage, resulting in a loss of power and causing the motor to overheat. Use the chart provided below to determine the minimum wire size required in an extension cord. Only round jacketed cords listed by Underwriter's Laboratories (UL) should be used.

**Ampere rating (on tool data plate)

Cord Length	Wire Size (A.W.G.)					
	0-2.0	2.1-3.4	3.5-5.0	5.1-7.0	7.1-12.0	12.1-16.0
25'	16	16	16	16	14	14
50'	16	16	16	14	14	12
100'	16	16	14	12	10	—

**Used on 12 gauge - 20 amp circuit.

NOTE: AWG = American Wire Gauge

When working with the tool outdoors, use an extension cord that is designed for outside use. This is indicated by the letters "WA" on the cord's jacket.

Before using an extension cord, inspect it for loose or exposed wires and cut or worn insulation.

WARNING:

Keep the extension cord clear of the working area. Position the cord so that it will not get caught on lumber, tools or other obstructions while you are working with a power tool. Failure to do so can result in serious personal injury.

WARNING:

Check extension cords before each use. If damaged replace immediately. Never use tool with a damaged cord since touching the damaged area could cause electrical shock resulting in serious injury.

ELECTRICAL CONNECTION

This tool is powered by a precision built electric motor. It should be connected to a **power supply that is 120 volts, 60 Hz, AC only (normal household current)**. Do not operate this tool on direct current (DC). A substantial voltage drop will cause a loss of power and the motor will overheat. If the machine does not operate when plugged into an outlet, double check the power supply.

SPEED AND WIRING

The no-load speed of this tool is approximately 3,900 rpm. This speed is not constant and decreases under a load or with lower voltage. For voltage, the wiring in a shop is as important as the motor's horsepower rating. A line intended only for lights cannot properly carry a power tool motor. Wire that is heavy enough for a short distance will be too light for a greater distance. A line that can support one power tool may not be able to support two or three tools.

GROUNDING INSTRUCTIONS

In the event of a malfunction or breakdown, grounding provides a path of least resistance for electric current to reduce the risk of electric shock. This tool is equipped with an electric cord having an equipment-grounding conductor and a grounding plug. The plug must be plugged into a matching outlet that is properly installed and grounded in accordance with all local codes and ordinances.

Do not modify the plug provided. If it will not fit the outlet, have the proper outlet installed by a qualified electrician. Improper connection of the equipment-grounding conductor can result in a risk of electric shock. The conductor with insulation having an outer surface that is green with or without yellow stripes is the equipment-grounding conductor. If repair or replacement of the electric cord or plug is necessary, do not connect the equipment-grounding conductor to a live terminal.

Check with a qualified electrician or service personnel if the grounding instructions are not completely understood, or if in doubt as to whether the tool is properly grounded.

Repair or replace a damaged or worn cord immediately.

This tool is intended for use on a circuit that has an outlet like the one shown in figure 1. It also has a grounding pin like the one shown.

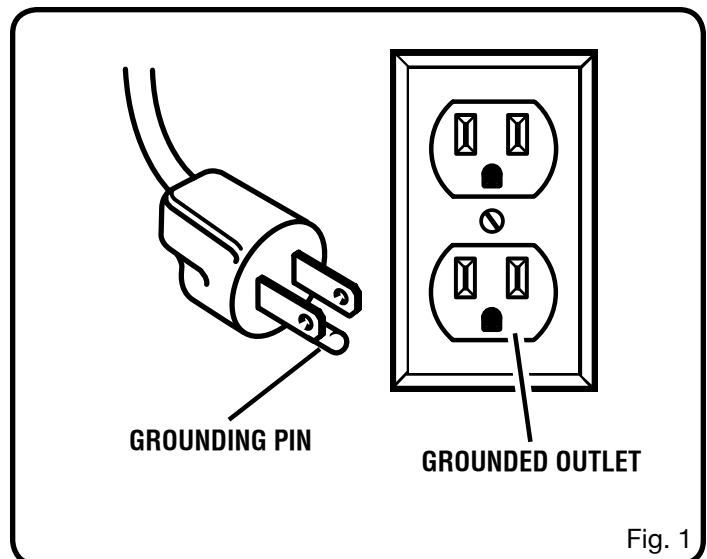

Fig. 1

FEATURES

PRODUCT SPECIFICATIONS

- Input..... 120V, 60 Hz, AC Only, 15 Amps
- No Load Speed.....3,900/min.
- Arbor Diameter 1 in.
- Wheel Diameter 14 in.
- Net Weight37.6 lbs.
- Fence Angle.....Right (45°), Left (45°)
- Vise Clamp AngleRight (45°), Left (45°)
- Maximum Cutting Capacities:
 - Round Pipe 5 in. outside diameter
 - Angle Stock 6-1/2 in. wide x 3-5/16 in. tall
 - Flat Metal Stock..... 2-1/2 in. x 9-1/2 in.

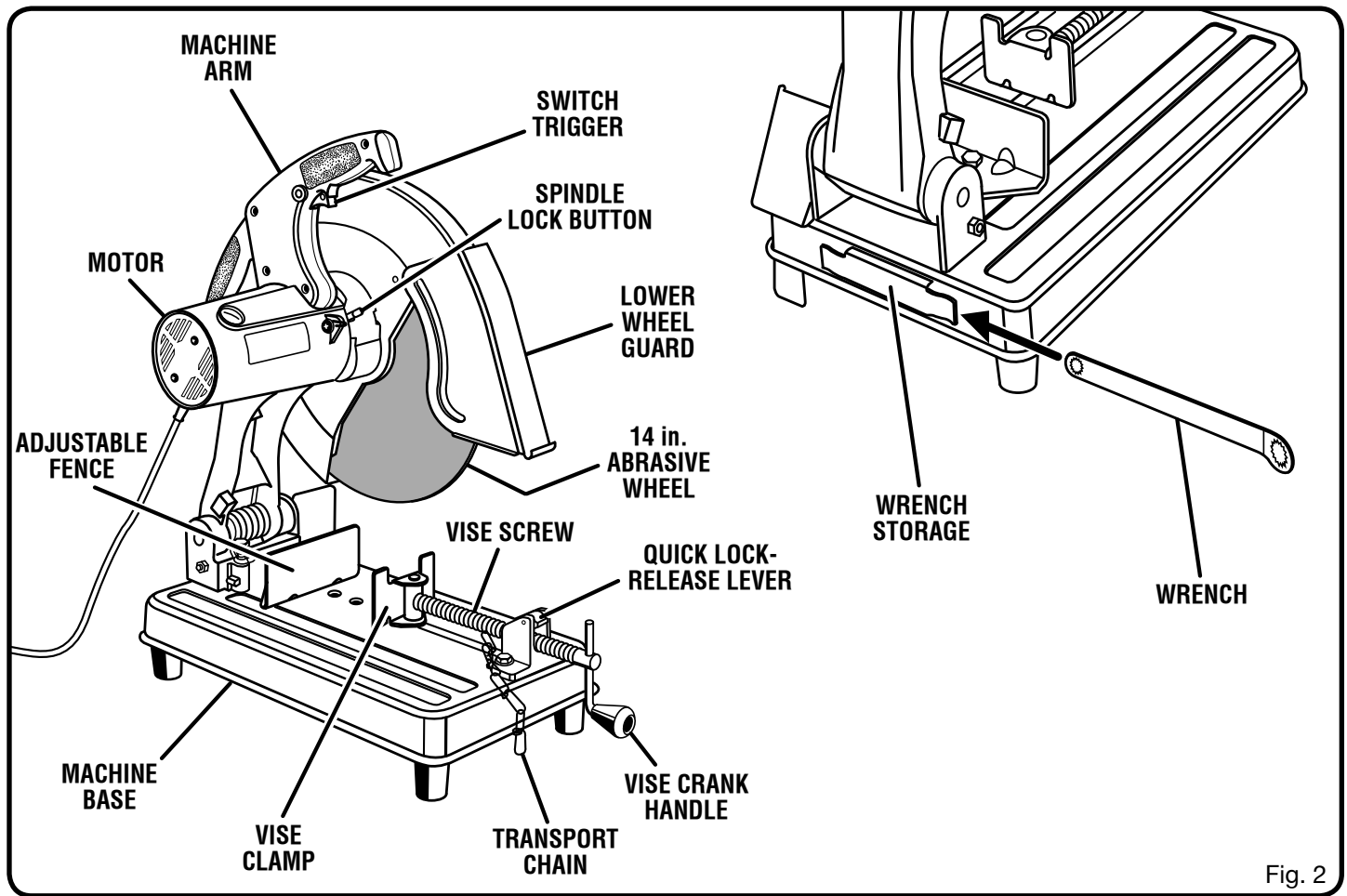

Fig. 2

KNOW YOUR CUT-OFF MACHINE

See Figures 2 - 3.

Before attempting to use your machine, familiarize yourself with all operating features and safety requirements.

MOTOR

This machine has a strong motor with sufficient power to handle tough cutting jobs. It also has externally accessible brushes for ease of servicing.

14 in. ABRASIVE WHEEL

A 14 in. abrasive wheel is included with the cut-off machine. It will cut materials up to 5 in. thick or 8 in. wide, depending upon the thickness or width of the material and the setting at which the cut is being made.

SELF-RETRACTING LOWER WHEEL GUARD

The lower wheel guard provides protection from each side of the wheel. It retracts over the upper wheel guard as the wheel is lowered into the workpiece.

SPINDLE LOCK BUTTON

A spindle lock button has been provided for locking the spindle which keeps the wheel in the machine from rotating. Depress and hold the spindle lock button while installing, changing, or removing wheel only.

QUICK LOCK-RELEASE LEVER

A quick lock-release lever has been provided on the cut-off machine. This feature allows you to open and close the vise clamp quickly without repetitive turning of the vise crank handle.

FEATURES

WISE CLAMP

A vise clamp has been provided with the cut-off machine. It is located on the end of the vise screw and provides greater control by clamping the material to the fence. It also prevents the material from creeping toward the wheel during a cutting operation.

ADJUSTABLE FENCE

The fence on the cut-off machine has been provided to support the material and provide clamping support to the vise for holding the material securely when making all cuts. It is an adjustable fence that has been provided to make the cut-off machine more versatile. It adjusts from 0° to 45° to the right for making angled cuts. The hole pattern allows it to be moved forward when making cuts in tall or thick stock, such as square stock or tube stock. The hole pattern allows it to be moved back when making cuts in stock that is thin or wide, such as angle stock.

CARRYING HANDLE

For convenience when carrying or transporting the cut-off machine from one place to another, a carrying handle has been provided on top of the machine arm as shown in figure 3. To transport, turn off and unplug the machine, then lower machine arm and lock it in the down position. Use the transport chain to lock machine arm in the down position.

LOCK-ON BUTTON

See Figure 3.

The cut-off machine is equipped with a lock-on feature which is convenient when continuous cutting for extended periods of time is required. To engage the lock-on feature, depress switch trigger, push in and hold the lock-on button located on the side of the handle, then release switch trigger. Release lock-on button and machine will continue running.

To release lock-on feature, depress switch trigger and release.

If you have the lock-on feature engaged during use and the machine becomes disconnected from power supply, disengage the lock-on feature immediately.

TRIGGER LOCK

See Figure 4.

To prevent unauthorized use of the cut-off machine, we suggest that you disconnect it from the power supply and lock the switch in the off position. To lock the switch, install a padlock (not included) through the hole in the switch trigger. A lock with a shackle up to 1/4 in. diameter may be used. When the lock is installed and locked, the switch is inoperable. Store the padlock key in another location.

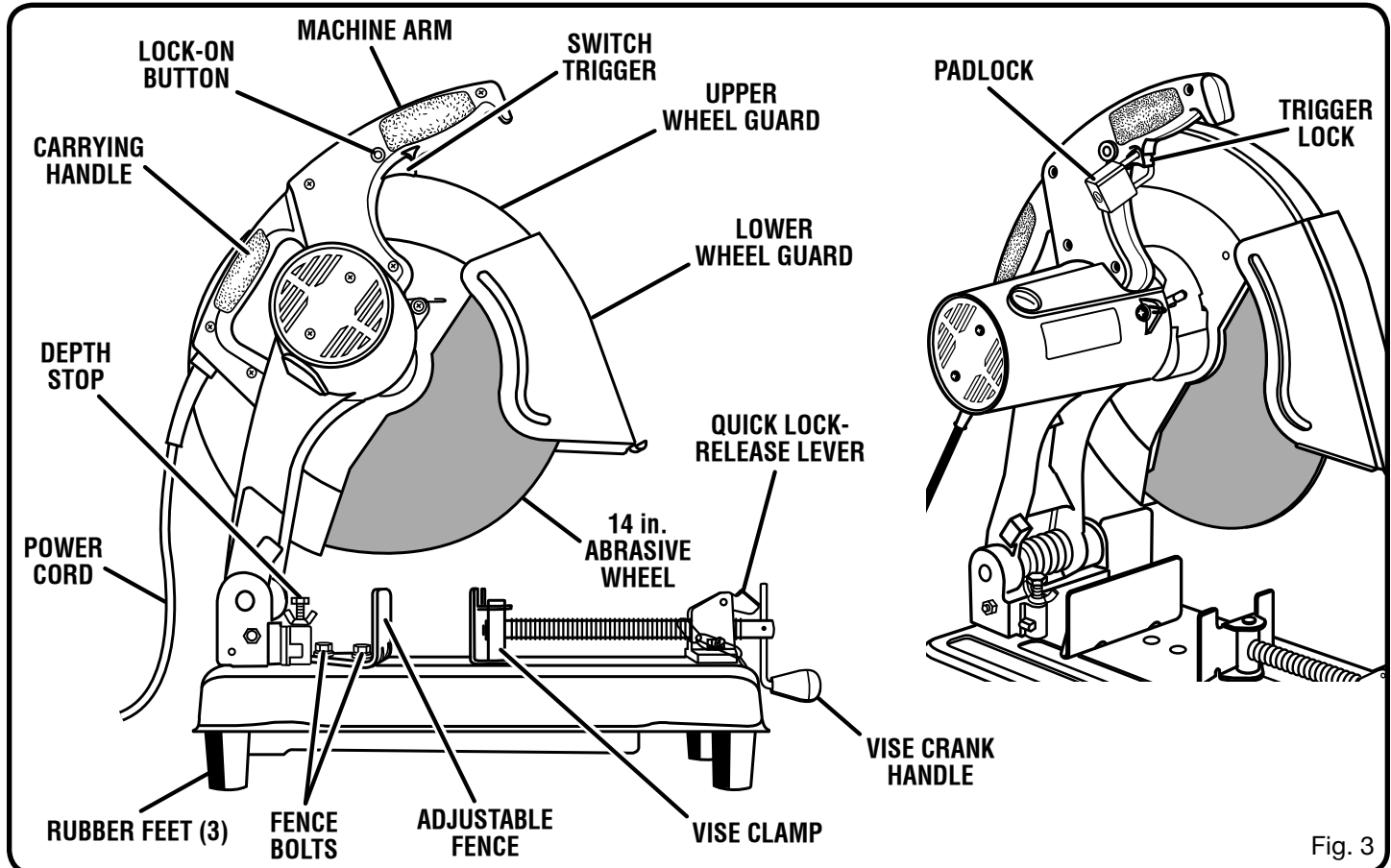

Fig. 3

LOOSE PARTS

The following items are included with your tool:

- Hex Wrench
- Operator's Manual
- Warranty Registration

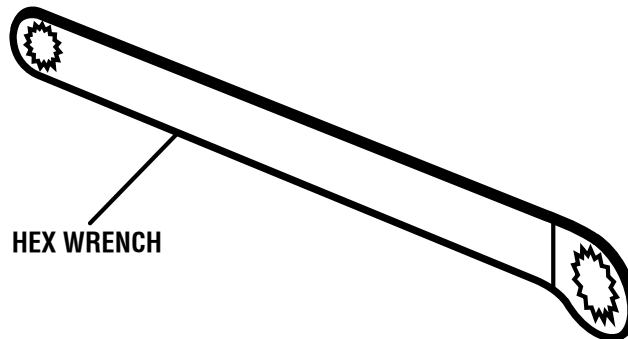

Fig. 4



WARNING: The use of attachments or accessories not listed might be hazardous and could cause serious personal injury.

ASSEMBLY

UNPACKING

This product has been shipped completely assembled.

- Carefully lift machine from the carton by the carrying handle and the machine base, and place it on a level work surface.

NOTE: This tool is heavy. To avoid back injury, lift with your legs, not your back, and get help when needed.

- This machine has been shipped with the machine arm secured in the down position. To release the machine arm, push down on the top of the machine arm, and unhook the transport chain.
- Inspect the tool carefully to make sure no breakage or damage occurred during shipping.
- Do not discard the packing material until you have carefully inspected and satisfactorily operated the tool.
- The machine is factory set for accurate cutting. After assembling it, check for accuracy. If shipping has influenced the settings, refer to specific procedures explained in this manual.
- If any parts are damaged or missing, please call 1-800-525-2579 for assistance.



WARNING:

If any parts are missing do not operate this tool until the missing parts are replaced. Failure to do so could result in possible serious personal injury.



WARNING:

Do not attempt to modify this tool or create accessories not recommended for use with this tool. Any such alteration or modification is misuse and could result in a hazardous condition leading to possible serious personal injury.



WARNING:

Do not connect to power supply until assembly is complete. Failure to comply could result in accidental starting and possible serious personal injury.



WARNING:

A 14 in. wheel is the maximum wheel capacity of your cut-off machine. Never use a wheel that is too thick to allow outer flange to engage with the flats on the spindle. Larger wheels will come in contact with the wheel guards, while thicker wheels will prevent the bolt from securing the wheel on the spindle. Either of these situations could result in a serious accident and can cause serious personal injury.

ASSEMBLY

REMOVAL / INSTALLATION OF WHEEL TO REMOVE

See Figure 5.

- Unplug the cut-off machine.
- Push down on machine arm and remove transport chain from hook on motor housing to release machine arm.
- Raise machine arm to its full raised position. Be cautious when raising, machine arm is spring loaded.
- Rotate lower wheel guard upward, exposing the hex head bolt that secures abrasive wheel to wheel arbor.
- Depress the spindle lock button and rotate bolt until spindle locks, preventing shaft from rotating.
- Using the hex wrench provided, loosen and remove bolt.

NOTE: Bolt has right hand threads. Turn bolt counter-clockwise to loosen.

- Remove outer washer, outer flange, spacer, and wheel. Do not remove inner flange or inner washer. Removal of these two parts are not required for wheel changes.

⚠ WARNING:

If inner flange or inner washer has been removed, replace both before placing wheel on spacer and wheel arbor. Failure to do so could cause an accident since wheel will not tighten properly.

TO INSTALL

See Figure 5.

- Unplug the cut-off machine.
- Inspect the replacement wheel for defects such as cracks, chipping, and correct speed rating. If defects are found or the speed rating is not greater than 3,900 rpm, do not use. Select another wheel.
- Clean debris from the inner washer and inner flange.
- Place new wheel over spacer, then place both on wheel arbor against inner flange.
- Clean outer flange, then align flats with flats on wheel arbor and slide it onto arbor until it is flush against wheel.
- Place the recessed side of the outer washer against the arbor, then insert the hex head bolt into the threaded end of the wheel arbor.
- Start threads and turn bolt clockwise to snugly tighten.
- Depress the spindle lock button and rotate bolt until spindle locks, preventing shaft from rotating.
- Using the hex wrench provided, securely tighten hex head bolt.

NOTE: Bolt has right hand threads. Turn bolt clockwise to tighten.

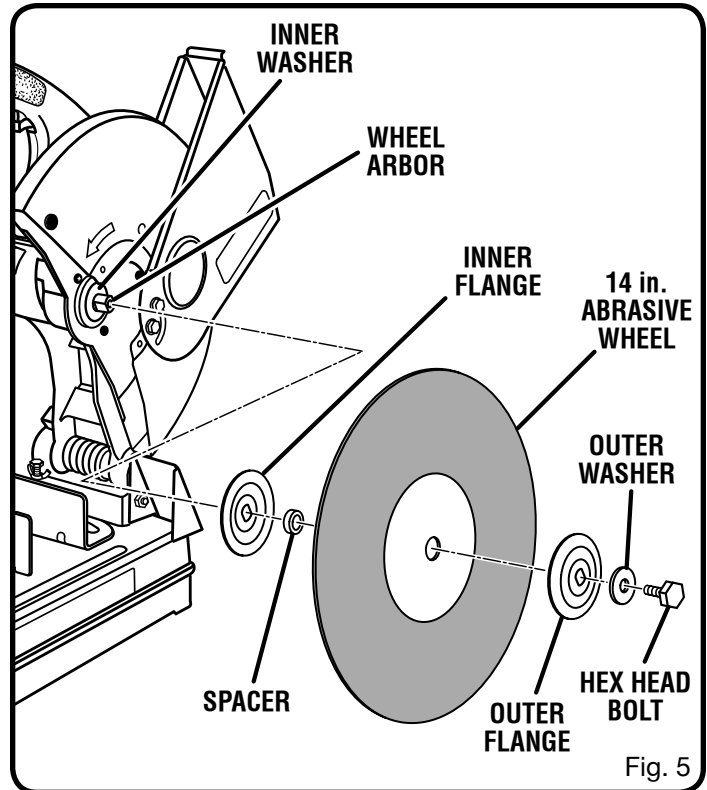

⚠ WARNING:

Do not overtighten hex head bolt. Overtightening can cause the new wheel to crack, resulting in premature failure and possible serious personal injury.

MOUNT TO A METAL WORK SURFACE

Three predrilled holes are provided in the machine's base for mounting to a metal work surface. Use proper length, 3/8 in. diameter bolts, nuts, and washers for mounting (hardware not included).

ASSEMBLY

ADJUSTABLE FENCE

See Figure 6.

The adjustable fence is located at the rear of the cut-off machine. As mentioned previously, it is used along with the vise clamp to provide a clamp for holding the workpiece securely when making cuts. It also makes the cut-off machine more versatile.

The fence can be rotated to obtain cutting angles from 0° to 45°. It also can be moved back to allow greater cutting widths in thin stock, or forward to allow greater cutting depths in tall or thick stock.

CUTTING ANGLE ADJUSTMENT

See Figures 6 - 7.

- Unplug the cut-off machine.
- Using the hex wrench supplied, loosen the two hex head bolts securing adjustable fence. See Figure 7.
- Rotate fence until the desired angle of cut on the scale is aligned with the indicator in machine base.
- For precise cuts, check the angle of cut for the fence against the abrasive wheel with a protractor, bevel square, or other similar device.
- Using the hex wrench supplied, securely tighten hex head bolts. Return hex wrench to its storage area in base.
- This will secure the fence in place at desired angle. See Figure 6.

ADJUSTING WIDTH OF CUT

See Figures 7 - 8.

- Unplug the cut-off machine.
- To increase the width of cut of the cut-off machine, use the hex wrench to loosen and remove the hex head bolts and washers securing fence to machine base.
- Reposition the curved slot of the fence with the threaded hole in back of the machine base.
- Install a hex head bolt through a lock washer and flat washer into machine base. Do not tighten bolt securely.
- Align remaining fence bolt hole with the middle threaded hole in the machine base.
- Install hex head bolt through lock washer and flat washer into machine base.
- Check and adjust fence to desired cutting angle.
- Using the hex wrench supplied, securely tighten hex head bolts. Return hex wrench to its storage area in base.
- This position is good for cutting thin and wide pieces of stock, such as flat or angled stock.
- To increase the height of cut of the cut-off machine, follow the above procedure except place the rear hex head bolt in the middle threaded hole and the front hex head bolt in the front threaded hole.
- Check and adjust fence to desired cutting angle.

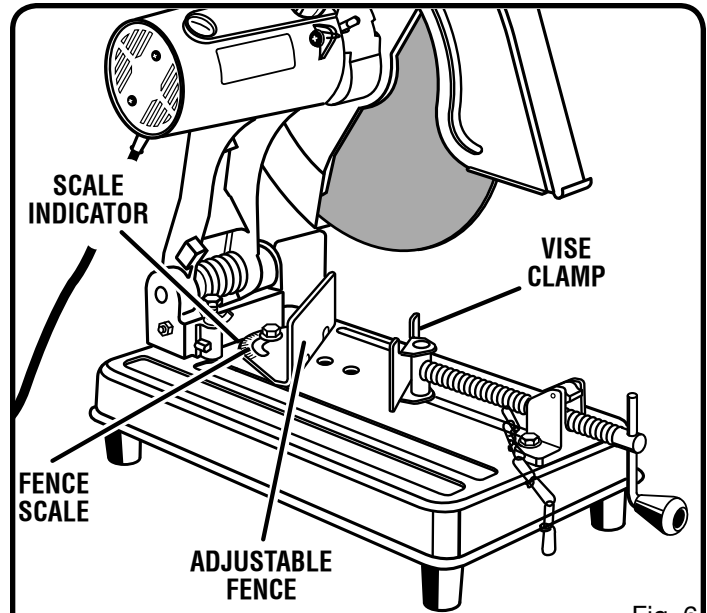

Fig. 6

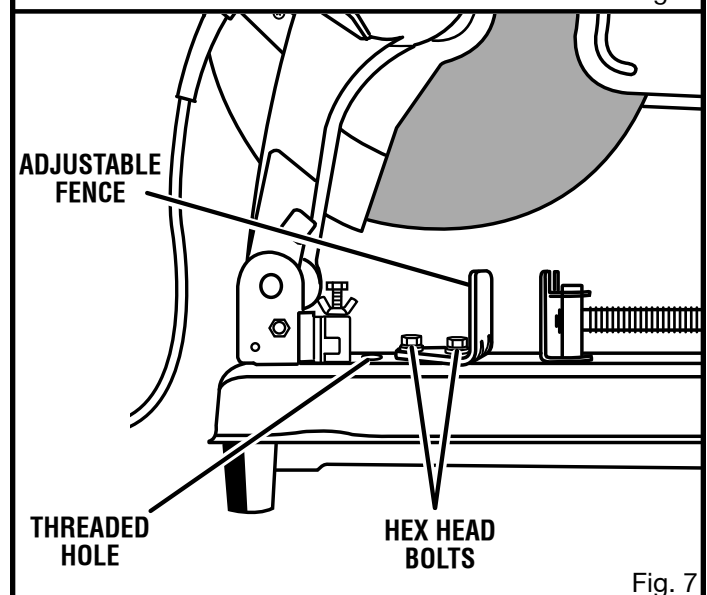

Fig. 7

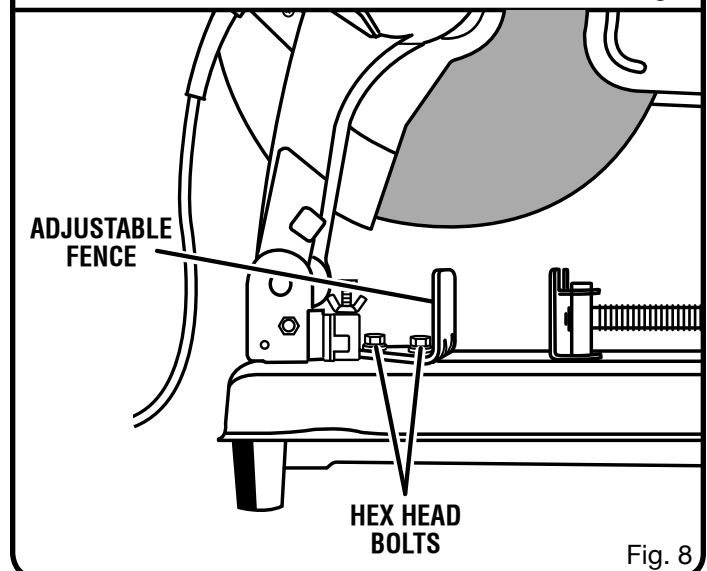

Fig. 8

ASSEMBLY

- Using the hex wrench supplied, securely tighten hex head bolts. Return hex wrench to its storage area in base.
- This position is good for cutting tall and thick pieces of stock, such as square or tube stock.

QUICK LOCK-RELEASE LEVER

See Figures 9 - 10.

The quick lock-release lever engages the vise clamp to be used along with the fence to provide a vise for securing the workpiece to be cut. It also allows you to open and close the vise quickly without repetitive turning of the vise crank handle.

USING THE QUICK LOCK-RELEASE LEVER AND VISE CLAMP

To loosen:

See Figure 9.

- Unplug the cut-off machine.
- Release tension on the vise clamp by rotating the vise crank handle 1/2 to 1 turn counterclockwise.
- Lift up the quick lock-release lever as shown in figure 9 and pull back on vise crank handle to slide open the vise.

To tighten:

See Figure 10.

- Unplug the cut-off machine.
- Push the vise crank handle forward to slide the vise clamp against the workpiece.
- Rotate the quick lock-release lever forward and push down as shown in figure 10 to engage its threads with the vise screw.
- Rotate the vise crank handle clockwise to tighten the vise clamp against the workpiece.

DEPTH STOP

See Figure 11.

The depth stop limits the wheel's downward travel. It allows the wheel to go below the machine base enough to maintain full cutting capacities.

The adjustable depth stop is a bolt threaded into the base at the rear of the machine. To adjust the depth stop, use the hex wrench supplied to raise or lower the depth stop bolt.

The depth stop is factory set to provide maximum cutting capacity for the 14 in. abrasive wheel provided with the cut-off machine.

When the diameter of the wheel has been reduced due to wear, it may be necessary to adjust the depth stop to provide maximum cutting capacity. When a new abrasive wheel is installed, it is necessary to check the clearance of the wheel to the machine base support.

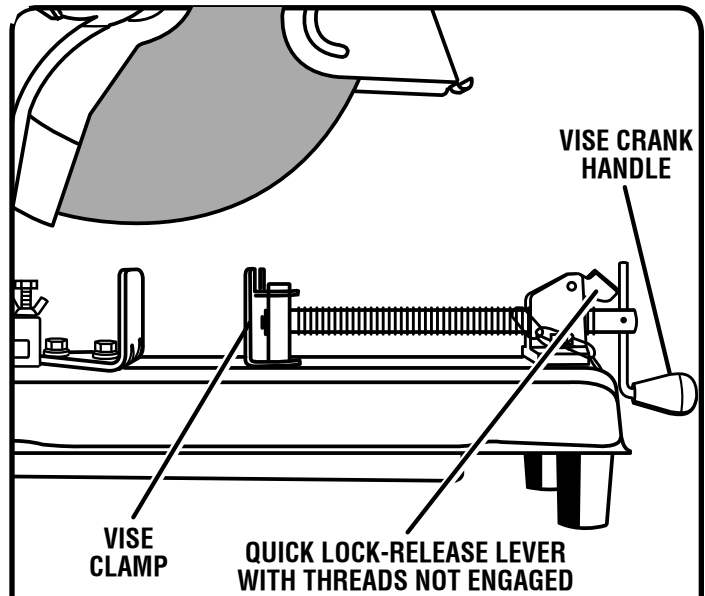

Fig. 9

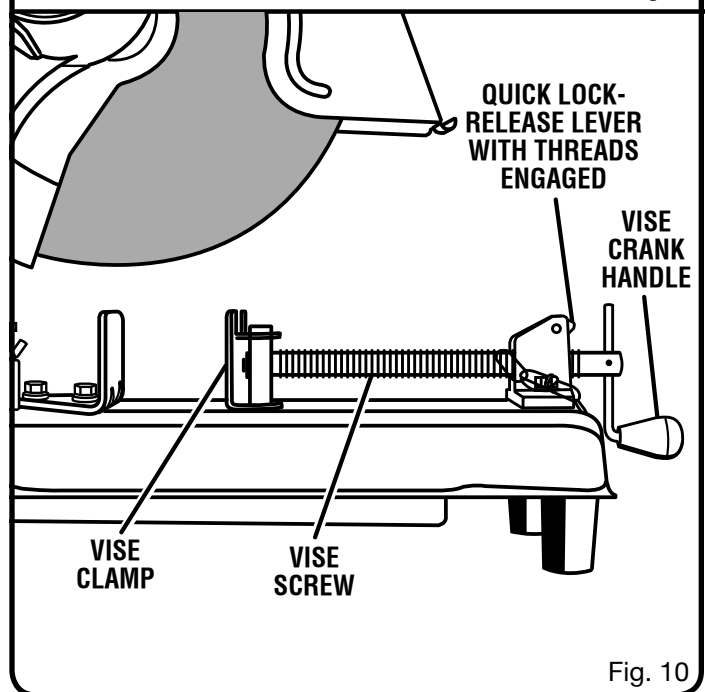

Fig. 10

DEPTH STOP ADJUSTMENTS

See Figure 11.

- Unplug the cut-off machine.
- Loosen depth stop bolt that is against the machine base.
- The depth stop is lowered by turning depth stop bolt clock-wise and raised by turning bolt counterclockwise.
- By pressing down on the machine arm, lower the wheel and check clearance and maximum cutting distance (distance from adjustable stationary vise where wheel enters) to front of machine base slot.
- Adjust if necessary.

ASSEMBLY

⚠ CAUTION:

Do not start the abrasive cut-off machine without checking for interference between the wheel and the machine base support. Damage may result to the wheel if it strikes the machine base support during operation of the machine.

- Tighten the depth stop bolt with the hex wrench provided.

⚠ WARNING:

Cutting steel will cause sparks. Do not operate in the presence of combustible or flammable materials. Failure to heed this warning could result in a fire or serious personal injury.

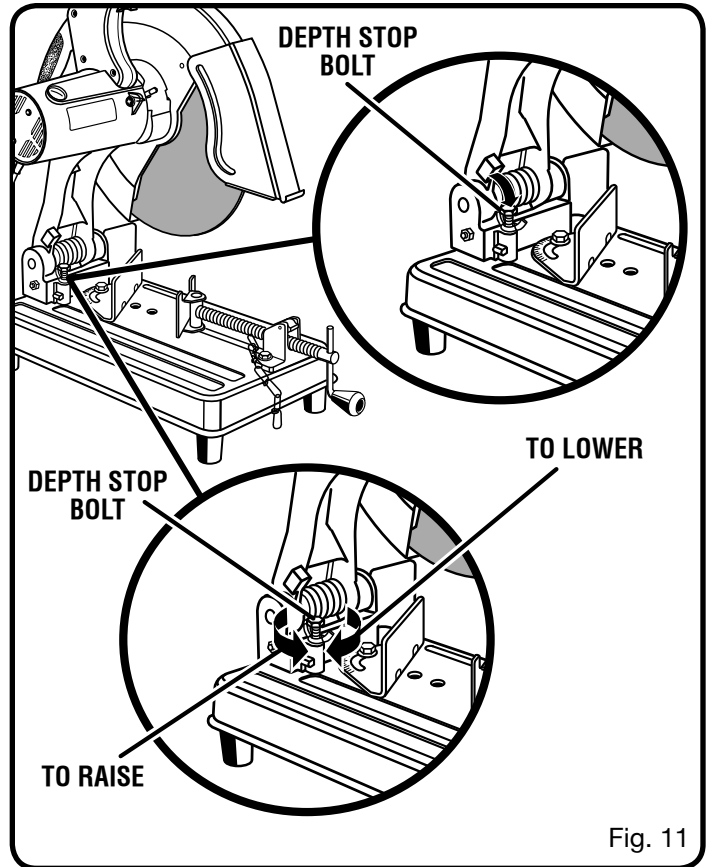

Fig. 11

OPERATION

⚠ WARNING:

Do not allow familiarity with tools to make you careless. Remember that a careless fraction of a second is sufficient to inflict serious injury.

⚠ WARNING:

Always wear safety goggles or safety glasses with side shields when operating power tools. Failure to do so could result in objects being thrown into your eyes resulting in possible serious injury.

⚠ WARNING:

Do not use any attachments or accessories not recommended by the manufacturer of this tool. The use of attachments or accessories not recommended can result in serious personal injury.

⚠ WARNING:

Do not attempt to cut wood or masonry with this cut-off machine. Never cut magnesium or magnesium alloy with this machine. Failure to comply could result in serious personal injury.

⚠ WARNING:

Never install any wood cutting blade on this machine. The cut-off machine is properly guarded only for cutting metal with an abrasive wheel. Failure to comply could result in serious personal injury.

APPLICATIONS

You may use this tool for the purposes listed below:

- Cutting most types of metals such as 2 in. x 6 in. steel framing studs.
- Cutting hard metal iron stock such as square bar stock and angle iron.
- Cutting metal tube and pipe stock.

OPERATION

POWER SUPPLY

Before operating the cut-off machine, check the power supply and make sure it meets the requirements listed on the tool's data plate. A substantial voltage drop will cause a loss of power and machine overheating.

Common causes of power loss and machine overheating are insufficient extension cord size and multiple tools operating from the same power source.

SWITCH TRIGGER

To turn the cut-off machine ON, depress the switch trigger located in the handle portion of the machine arm.

To turn it OFF, release the switch trigger.

LOCK-ON BUTTON

To engage the lock-on feature, depress the switch trigger, push in and hold the lock-on button located on the side of the handle, then release switch trigger. Release lock-on button and the machine will continue running.

To release the lock-on feature, depress the switch trigger and release.

If you have the lock-on feature engaged during use and the machine becomes disconnected from power supply, or in the event of a power failure, disengage the lock-on feature immediately.

CUTTING WITH THE CUT-OFF MACHINE

See Figures 12 - 13.

⚠ WARNING:

Do not attempt to cut wood or masonry with this cut-off machine. Never cut magnesium or magnesium alloy with this machine. Failure to comply could result in serious personal injury.

- To prevent machine movement or tipping during cutting procedure, secure cut-off machine in place to a work-bench or work surface that is also secure.

⚠ WARNING:

Always use the vise on the cut-off machine to prevent accidents that could result in possible serious personal injury.

⚠ WARNING:

Never stand or have any part of your body in line with the path of the wheel. Doing so may cause an accident resulting in possible serious personal injury.

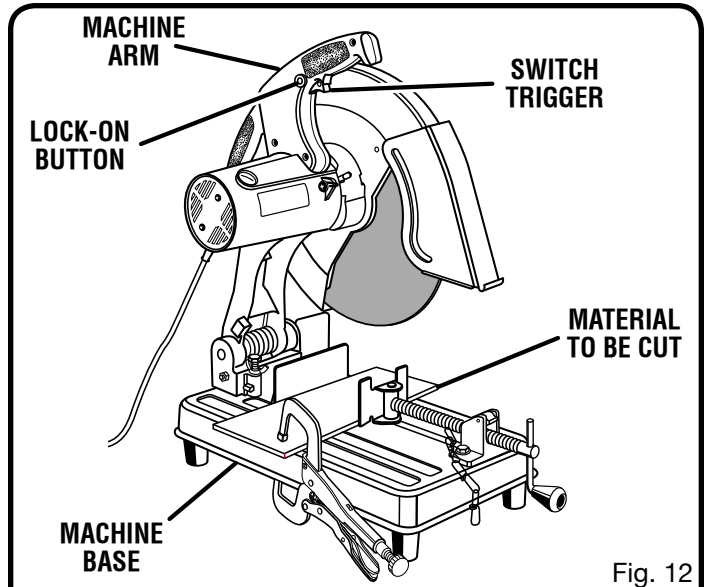

Fig. 12

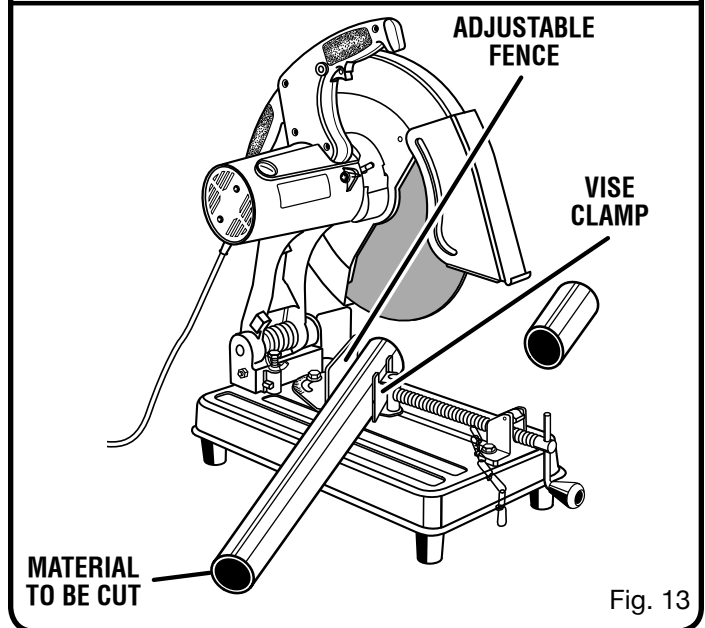

Fig. 13

⚠ WARNING:

Large, circular, or irregularly shaped material may require additional means of clamping to be secured in place adequately for cutting. Also use blocks to hold material securely. Failure to comply could result in serious personal injury.

⚠ WARNING:

To avoid accidental start up of the cut-off machine, always make sure switch is off and "lock-on" feature is disengaged before connecting to power source. Failure to heed this warning could result in serious personal injury.

OPERATION

CUT-OFF

See Figures 14 - 15.

A cut-off is made by cutting across the width of the workpiece. A straight crosscut is made with the adjustable fence set at the zero degree position. Angled cut-offs are made with the adjustable fence set at some angle other than zero.

To cut with the cut-off machine:

- Firmly secure the material to be cut using the machine's vise (adjustable fence and vise clamp).
- Using the hex wrench supplied, loosen the hex head bolts securing the fence. See Figures 14 and 15.
- Rotate the adjustable fence to the angle needed.
- Retighten hex head bolts securing fence.
- Return hex wrench to its storage area in base.

WARNING:

To avoid serious personal injury, always tighten hex head bolts securely before making a cut. Failure to do so could result in movement of the workpiece while making a cut.

- Place the workpiece flat on the machine base with one surface securely against the adjustable fence.
- Align cutting line on the workpiece with the edge of the abrasive wheel.
- Push in the vise crank handle to set the vise clamp against the workpiece. Turn the vise crank handle 1/2 to 1 turn clockwise to securely clamp the workpiece to the fence.

WARNING:

To avoid serious personal injury, keep your hands at least 3 in. from wheel.

- When cutting long pieces, support the opposite end of the material with a roller stand or with a work surface level with the machine base.

WARNING:

Never perform any cutting operation freehand (without placing workpiece in the vise). Material will get hot during cutting operation. Keep hands off of metal being cut to avoid serious personal injury.

- Before turning on machine, perform a dry run of the cutting operation just to make sure that no problems will occur when the cut is made.
- Start the machine by grasping the handle and fully squeezing the switch trigger. Allow several seconds for

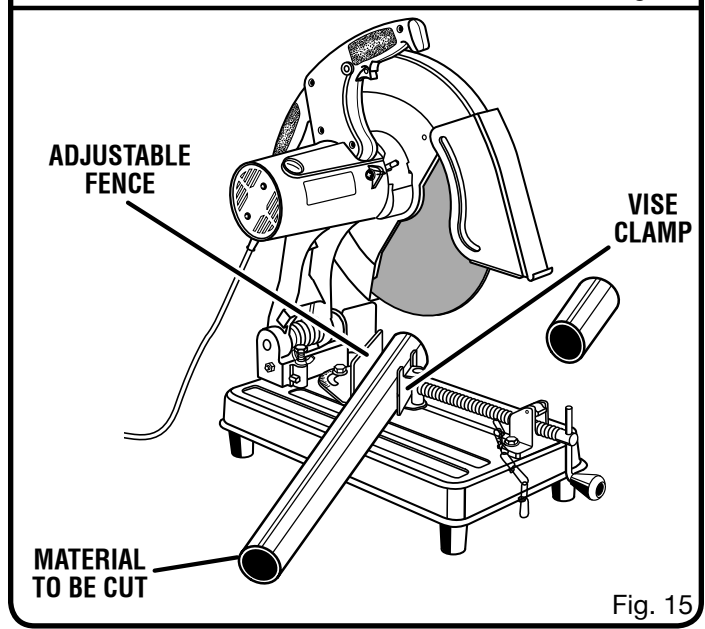
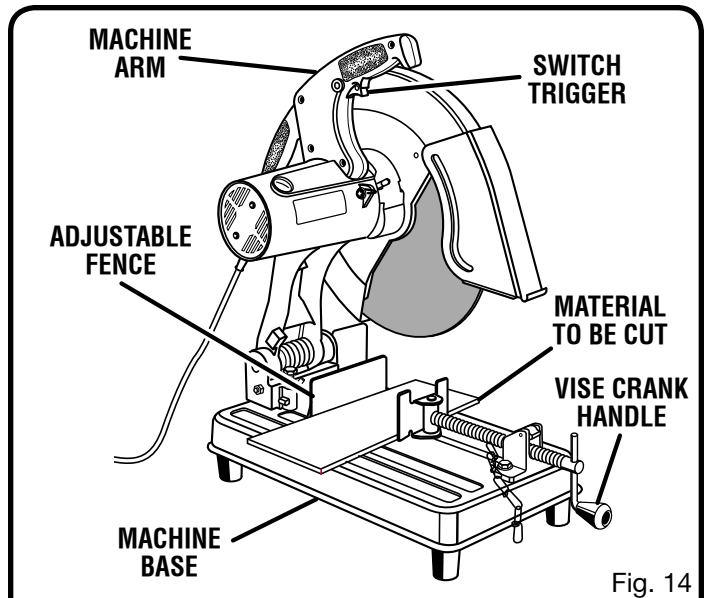

the wheel to build up to full speed before letting it come into contact with the material to be cut.

- Once it reaches full speed slowly lower the handle of the machine arm until the cut-off wheel comes in contact with the material being cut. Continue to use steady and even pressure to obtain a uniform cut through the workpiece. Never force the wheel into the material being cut.
- When the cut is complete, release the switch trigger and allow the wheel to stop rotating before raising the wheel out of workpiece.

WARNING:

Do not touch the cut material until it cools or you can be burned. Failure to heed this warning could result in serious personal injury.

MAINTENANCE

⚠ WARNING:

When servicing, use only identical Ryobi replacement parts. Use of any other parts may create a hazard or cause product damage.

⚠ WARNING:

Always wear safety goggles or safety glasses with side shields during power tool operation or when blowing dust. If operation is dusty, also wear a dust mask.

GENERAL MAINTENANCE

Avoid using solvents when cleaning plastic parts. Most plastics are susceptible to damage from various types of commercial solvents and may be damaged by their use. Use clean cloths to remove dirt, dust, oil, grease, etc.

⚠ WARNING:

Do not at any time let brake fluids, gasoline, petroleum-based products, penetrating oils, etc., come in contact with plastic parts. Chemicals can damage, weaken or destroy plastic which may result in serious personal injury.

Electric tools used on fiberglass material, wallboard, spackling compounds, or plaster are subject to accelerated wear and possible premature failure because the fiberglass chips and grindings are highly abrasive to bearings, brushes, commutators, etc. Consequently, we do not recommend using this tool for extended work on these types of materials. However, if you do work with any of these materials, it is extremely important to clean the tool using compressed air.

LUBRICATION

All of the bearings in this tool are lubricated with a sufficient amount of high grade lubricant for the life of the unit under normal operating conditions. Therefore, no further lubrication is required.

⚠ WARNING:

To ensure safety and reliability, all repairs (with the exception of the externally accessible brushes) should be performed by a Ryobi Authorized Service Center.

BRUSH REPLACEMENT

See Figure 16.

Your cut-off machine has externally accessible brush assemblies that should be periodically checked for wear.

Proceed as follows when replacement is required:

- Unplug the cut-off machine.

⚠ WARNING:

Failure to unplug cut-off machine could result in accidental starting causing possible serious personal injury.

- Remove brush cap with a screwdriver. Brush assembly is spring loaded and will pop out when you remove brush cap.
- Remove brush assembly.
- Check for wear. Replace both brushes when either has less than 1/4 in. length of carbon remaining. Do not replace one side without replacing the other.
- Reassemble using new brush assemblies. Make sure curvature of brush matches curvature of motor and that brush moves freely in brush tube.
- Make sure brush cap is oriented correctly (straight) and replace.
- Tighten brush cap securely. Do not overtighten.

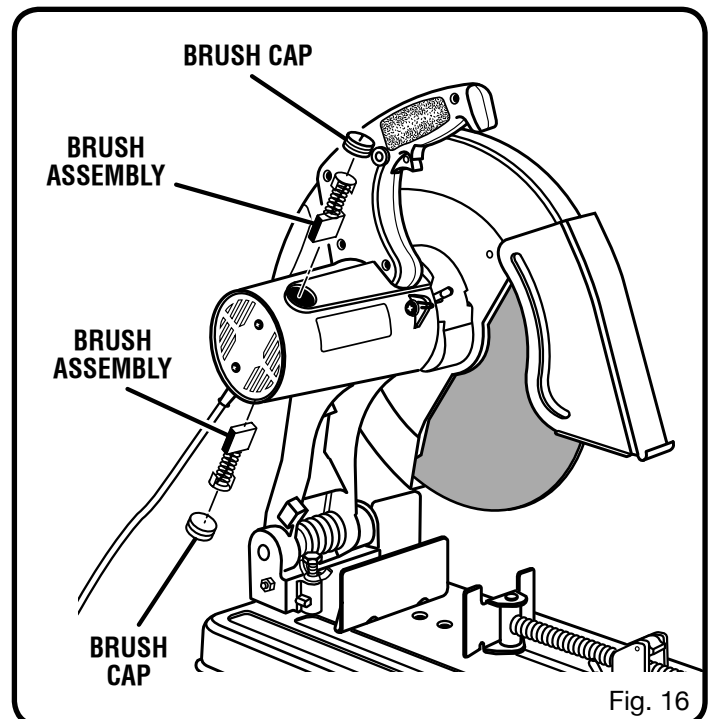

TROUBLESHOOTING

PROBLEM	CAUSE	SOLUTION
Machine does not start	<ol style="list-style-type: none"> 1. Power cord not plugged in. 2. Power cord is damaged. 3. Circuit breaker is tripped. 4. Circuit fuse is blown 5. Switch is damaged or burned out. 	<ol style="list-style-type: none"> 1. Plug in cord. 2. Have the cord replaced at your nearest authorized service center. 3. Reset circuit breaker. 4. Replace circuit fuse. 5. Have the switch replaced at your nearest authorized service center and request a voltage check from the power company.
Motor does not reach full speed or power.	<ol style="list-style-type: none"> 1. Voltage from power source is low. 2. Circuit is overloaded. 3. Motor burned out. 4. Fuses or circuit breakers are wrong size. 5. Extension cord is too long. 6. Switch is defective. 	<ol style="list-style-type: none"> 1. Request a voltage check from the power company. 2. Test on a different circuit or without anything else on circuit. 3. Have tool serviced; request voltage check from the power company. 4. Have an electrician replace with a 15 amp fuse or circuit breaker. 5. Use a shorter extension cord. 6. Have the switch replaced at your nearest authorized service center.
Motor stalls, blows fuses, or trips circuit breakers.	<ol style="list-style-type: none"> 1. Switch is defective. 2. Voltage from source is low. 3. Fuses or circuit breakers are wrong size or defective. 	<ol style="list-style-type: none"> 1. Have the switch replaced at your nearest authorized service center. 2. Request a voltage check from the power company. 3. Have an electrician replace with a 15 amp fuse or circuit breaker.
Motor overheats.	<ol style="list-style-type: none"> 1. Motor is overloaded. 2. Wheel is being fed into work too fast. 	<ol style="list-style-type: none"> 1. Request a voltage check from the power company. 2. Feed wheel into work slower.
Machine is noisy when running.	<ol style="list-style-type: none"> 1. Motor needs attention. 	<ol style="list-style-type: none"> 1. Have the motor checked at your nearest authorized service center.
Wheel hits table.	<ol style="list-style-type: none"> 1. Wheel not properly installed. 2. Depth stop setting incorrect. 	<ol style="list-style-type: none"> 1. See "Removal and Installation of Wheel" section. 2. Adjust the depth stop. See "Depth Stop" section.
Wheel does not cut through workpiece.	<ol style="list-style-type: none"> 1. Depth stop setting incorrect. 2. Wheel worn too much. 3. Incorrect cutting operation. 	<ol style="list-style-type: none"> 1. Adjust the depth stop. See "Depth Stop" section. 2. Replace with a new 14 in. abrasive cut off wheel. 3. See "Cut-Off" section.
Machine vibrates or shakes excessively.	<ol style="list-style-type: none"> 1. Wheel is out-of-round. 2. Wheel is chipped 3. Wheel is loose. 4. Machine is not secure. 5. Work surface is uneven. 	<ol style="list-style-type: none"> 1. Replace wheel. 2. Replace wheel. 3. Tighten wheel bolt on arbor. 4. Check and tighten all hardware. 5. Relocate and secure on a flat surface.



OPERATOR'S MANUAL

14 in. Abrasive Cut-Off Machine

C358

- SERVICE**

Now that you have purchased your tool, should a need ever exist for repair parts or service, simply contact your nearest Ryobi Authorized Service Center. Be sure to provide all pertinent facts when you call or visit. Please call 1-800-525-2579 for your nearest Ryobi Authorized Service Center. You can also check our web site at www.ryobitools.com for a complete list of Authorized Service Centers.

- MODEL NO. AND SERIAL NO.**

The model number of this tool will be found on a plate attached to the motor housing. Please record the model number and serial number in the space provided below.

- HOW TO ORDER REPAIR PARTS**

When ordering repair parts, always give the following information:

- MODEL NUMBER _____ C358 _____
- SERIAL NUMBER _____

RYOBI TECHNOLOGIES, INC.

1428 Pearman Dairy Road, Anderson, SC 29625
 Post Office Box 1207, Anderson, SC 29622-1207
 Phone 1-800-525-2579
www.ryobitools.com