

RYOBI

10 in. (254 mm) TABLE SAW

MODEL NO. BTS20R

REPAIR SHEET

RYOBI 10 in. (254 mm) TABLE SAW - MODEL NO. BTS20R

FIGURE A

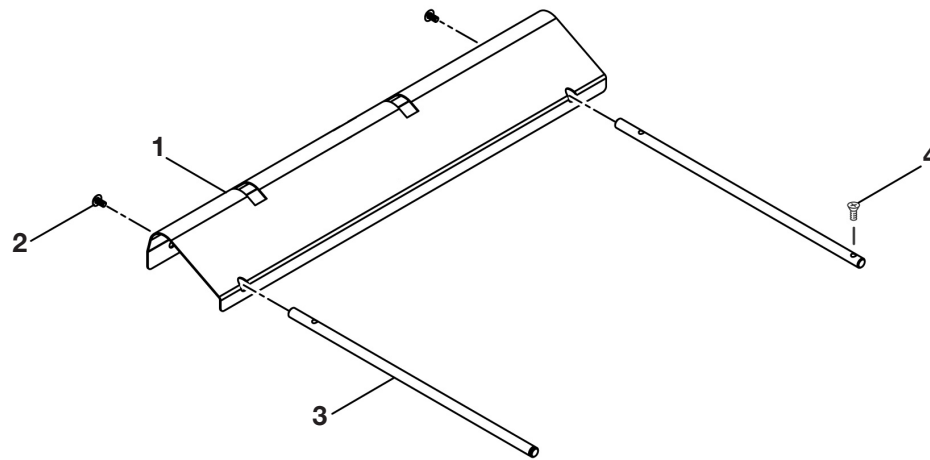

RYOBI 10 in. (254 mm) TABLE SAW - MODEL NO. BTS20R

The model number will be found on a plate attached to the motor housing. Always mention the model number in all correspondence regarding your **TABLE SAW** or when ordering repair parts.

PARTS LIST FOR FIGURE A

Key No.	Part Number	Description	Qty.
	A131013901	OUTFEED SUPPORT ASSEMBLY	
1	0131010314	OUTFEED SUPPORT	1
2	410551701	* SCREW (1/4-20 x 1/2 in.).....	2
3	0131010809	OUTFEED SUPPORT ROD	2
4	410182001	* STOP SCREW (M4 X 7 mm)	1

WARNING: Improper repair of a double insulated tool can result in damage to the double insulation system possibly causing electrical shock or electrocution. Any repairs requiring disassembly of your tool requires safety testing and should only be performed by a Ryobi Authorized Service Center. For the service center nearest you call 1-800-525-2579.

* Standard Hardware Item – May Be Purchased Locally

RYOBI 10 in. (254 mm) TABLE SAW - MODEL NO. BTS20R

FIGURE B

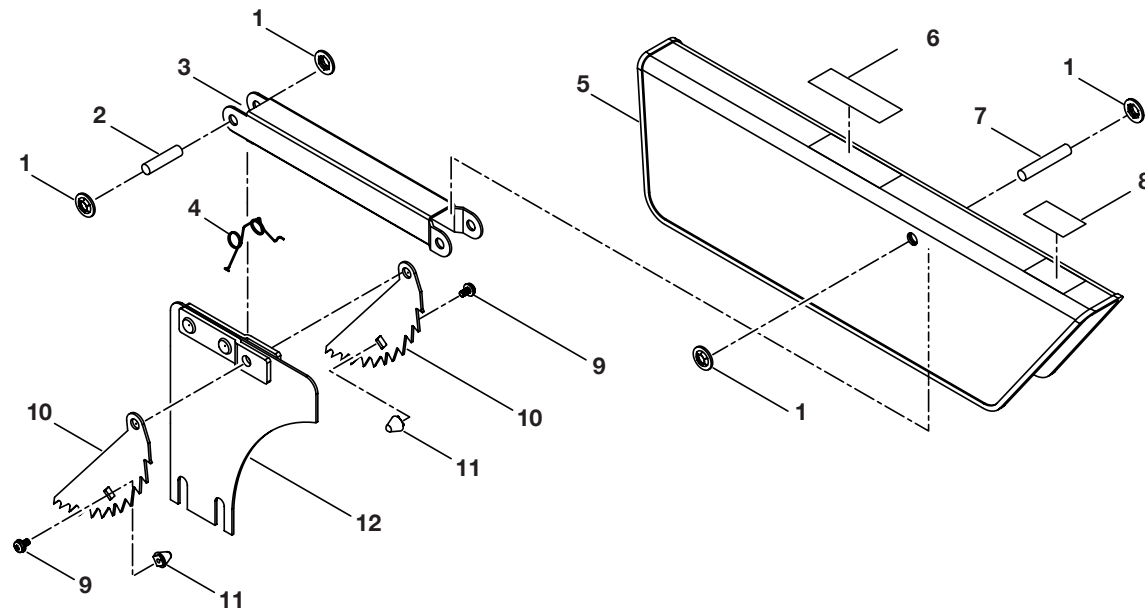

RYOBI 10 in. (254 mm) TABLE SAW - MODEL NO. BTS20R

The model number will be found on a plate attached to the motor housing. Always mention the model number in all correspondence regarding your **TABLE SAW** or when ordering repair parts.

PARTS LIST FOR FIGURE B

Key No.	Part Number	Description	Qty.
	A131011001	BLADE GUARD ASSEMBLY	
1	411105701	* PUSH NUT (5/16 in.)	4
2	414050003	* PIN (5/16 in. x 1-1/4 in.)	1
3	0131010303	ARM	1
4	0181010902	TORSION SPRING	1
5	0131010204	BLADE GUARD	1
6	9181015330203	WARNING LABEL	1
7	414050004	* PIN (5/16 in. x 1-3/4 in.)	1
8	9181015330202	HAND WARNING LABEL	1
9	0181010801	* SCREW AND WASHER (M4 x 7 mm).....	2
10	0181010303	ANTI-KICK BACK PAWL	2
11	0181010202	SPACER CAP	2
12	A131011601	RIVING KNIFE	1

WARNING: Improper repair of a double insulated tool can result in damage to the double insulation system possibly causing electrical shock or electrocution. Any repairs requiring disassembly of your tool requires safety testing and should only be performed by a Ryobi Authorized Service Center. For the service center nearest you call 1-800-525-2579.

* Standard Hardware Item – May Be Purchased Locally

RYOBI 10 in. (254 mm) TABLE SAW - MODEL NO. BTS20R

FIGURE C

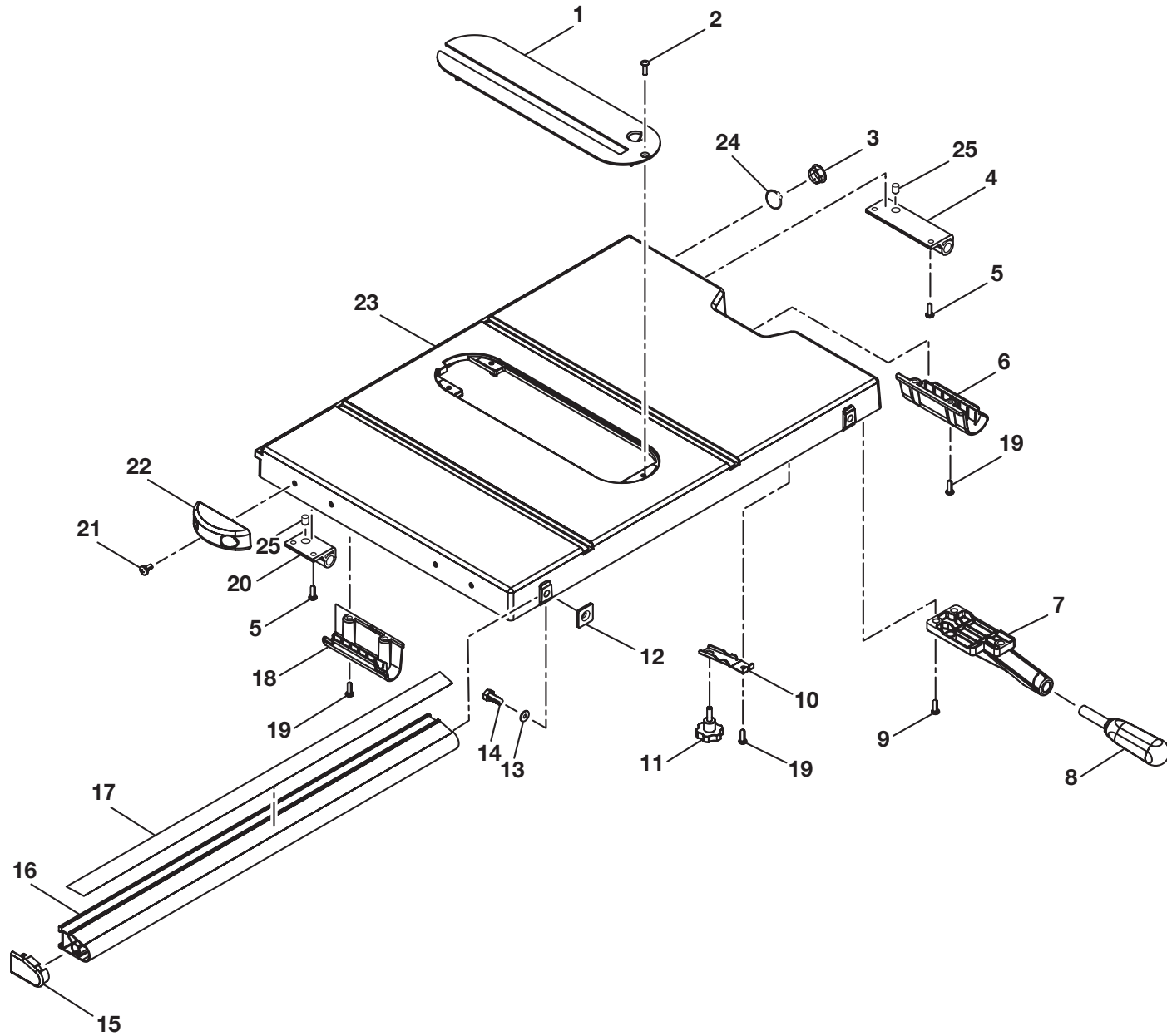

RYOBI 10 in. (254 mm) TABLE SAW - MODEL NO. BTS20R

The model number will be found on a plate attached to the motor housing. Always mention the model number in all correspondence regarding your **TABLE SAW** or when ordering repair parts.

PARTS LIST FOR FIGURE C

Key No.	Part Number	Description	Qty.	Key No.	Part Number	Description	Qty.
	A131017004	FRONT RAIL ASSEMBLY (Includes Fig. C Key No. 15, 16, 17; Fig. D Key No. 6, 7, 8, 9, 10, 20, 21, 22)		12	0181010317	SPECIAL NUT/RAIL WASHER.....	2
1	0131010316-35	THROAT PLATE	1	13	412011065	* WASHER (D8 x D16 x 0.8T).....	2
2	410101012	* SCREW (10-24 x 3/4 in. FLAT HD.)	1	14	410011723	* SCREW (5/16-18 x 14 mm HEX HD.)	2
3	0131010502	EXTENSION ROD BUSHING	2	15	0131010241	END CAP (LEFT).....	1
4	0131011806	RIGHT OUTFEED BRACKET	1	16	0131011808	MAIN RAIL	1
5	410171707	* SCREW (10-24 x 5/8 in.).....	4	17	9131015330305	SCALE, MAIN RAIL	1
6	0131010221	RIGHT CARRYING HANDLE	1	18	0131010229	LEFT CARRYING HANDLE.....	1
7	0131010108-94	AUXILIARY HANDLE BRACKET	1	19	410171706	* SCREW (10-24 x 1/2 in.).....	6
8	0181010227	FENCE LOCKING HANDLE/ AUXILIARY HANDLE	1	20	0131011805	LEFT OUTFEED BRACKET	1
9	0131010814	* SCREW (M6 x 25 mm HEX HD.).....	4	21	410331704	* SCREW (1/4-20 x 1/2 in.)	4
10	0131010321	EXTENSION ROD CLAMPING PLATE.....	2	22	0131010224	BUMPER	2
11	0131010225-35	KNOB, EXTENSION ROD	2	23	0131010105-33	TABLE	1
				24	413011014	C CLIP	2
				25	0131011305	RUBBER PLUG	2

WARNING: Improper repair of a double insulated tool can result in damage to the double insulation system possibly causing electrical shock or electrocution. Any repairs requiring disassembly of your tool requires safety testing and should only be performed by a Ryobi Authorized Service Center. For the service center nearest you call 1-800-525-2579.

* Standard Hardware Item – May Be Purchased Locally

RYOBI 10 in. (254 mm) TABLE SAW - MODEL NO. BTS20R

FIGURE D

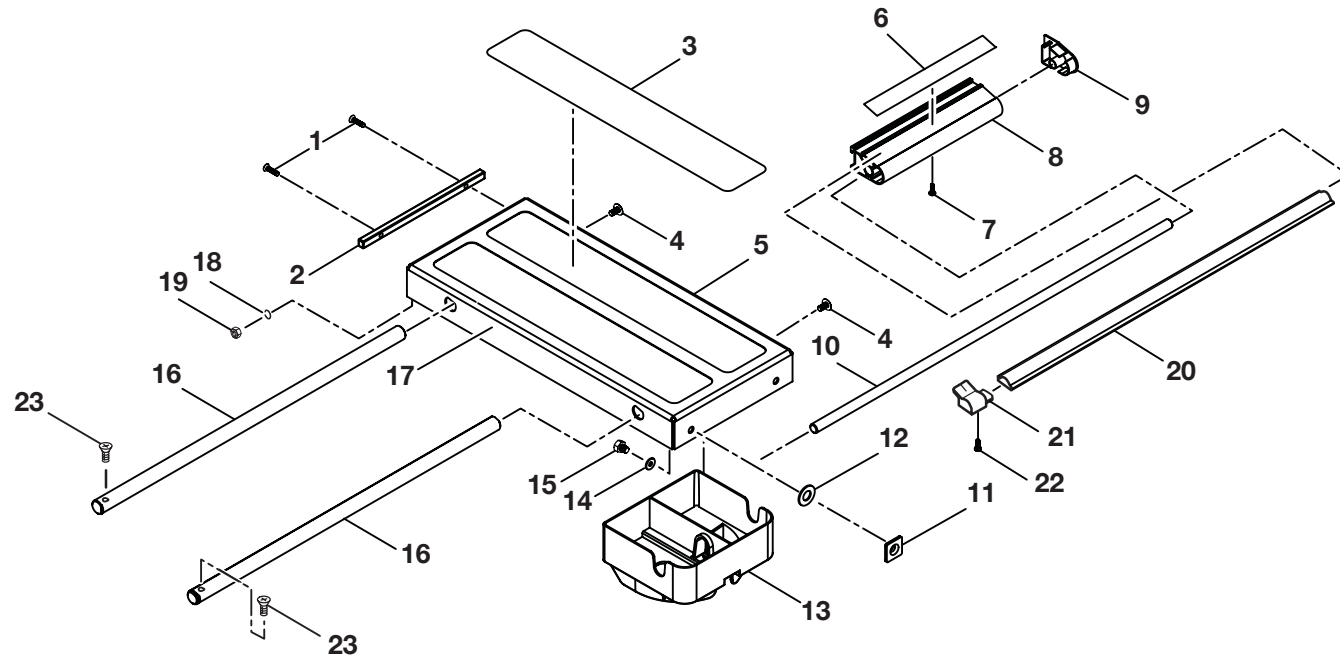

RYOBI 10 in. (254 mm) TABLE SAW - MODEL NO. BTS20R

The model number will be found on a plate attached to the motor housing. Always mention the model number in all correspondence regarding your **TABLE SAW** or when ordering repair parts.

PARTS LIST FOR FIGURE D

Key No.	Part Number	Description	Qty.	Key No.	Part Number	Description	Qty.
	A131013101	EXTENSION TABLE ASSEMBLY		12	412017086	* WASHER (D11 x D28 x 2.5T).....	2
1	410101012	* SCREW (10-24 FLAT HD.)	2	13	0131010220	MITER GAUGE HOLDER.....	1
2	0131010807	SQUARE BAR.....	1	14	412011065	* WASHER (D8 x D16 x 0.8T).....	2
3	9131015335703	TEAR-DOWN LABEL	1	15	410011720	* HEX SCREW (5/16-18 x 3/8 in.)	2
4	410551701	* SCREW AND WASHER (1/4-20 x 1/2 in.)... 2		16	0131010806	EXTENSION ROD	2
5	9131015335704	SET-UP LABEL	1	17	0131010313	EXTENSION TABLE	1
6	9131015330302	SCALE LABEL, SMALL RAIL.....	1	18	412021703	LOCK WASHER (M10).....	2
7	410132740	* SCREW (8-32 x 21 mm)	1	19	411011712	* HEX NUT (10-24 UNC)	2
8	0131011809	SMALL RAIL	1	20	0131011810	SCALE BAR	1
9	0131010242	END CAP (RIGHT)	1	21	0133010220	EXTENSION ROD INDICATOR	1
10	0131010808	JOINT BAR	1	22	410201004	* SCREW (M3 x 6 mm).....	1
11	0181010317	SPECIAL NUT/RAIL WASHER.....	2	23	410182001	* SCREW (4 x 7 mm PAN HD.).....	2

WARNING: Improper repair of a double insulated tool can result in damage to the double insulation system possibly causing electrical shock or electrocution. Any repairs requiring disassembly of your tool requires safety testing and should only be performed by a Ryobi Authorized Service Center. For the service center nearest you call 1-800-525-2579.

* Standard Hardware Item – May Be Purchased Locally

RYOBI 10 in. (254 mm) TABLE SAW - MODEL NO. BTS20R

FIGURE E

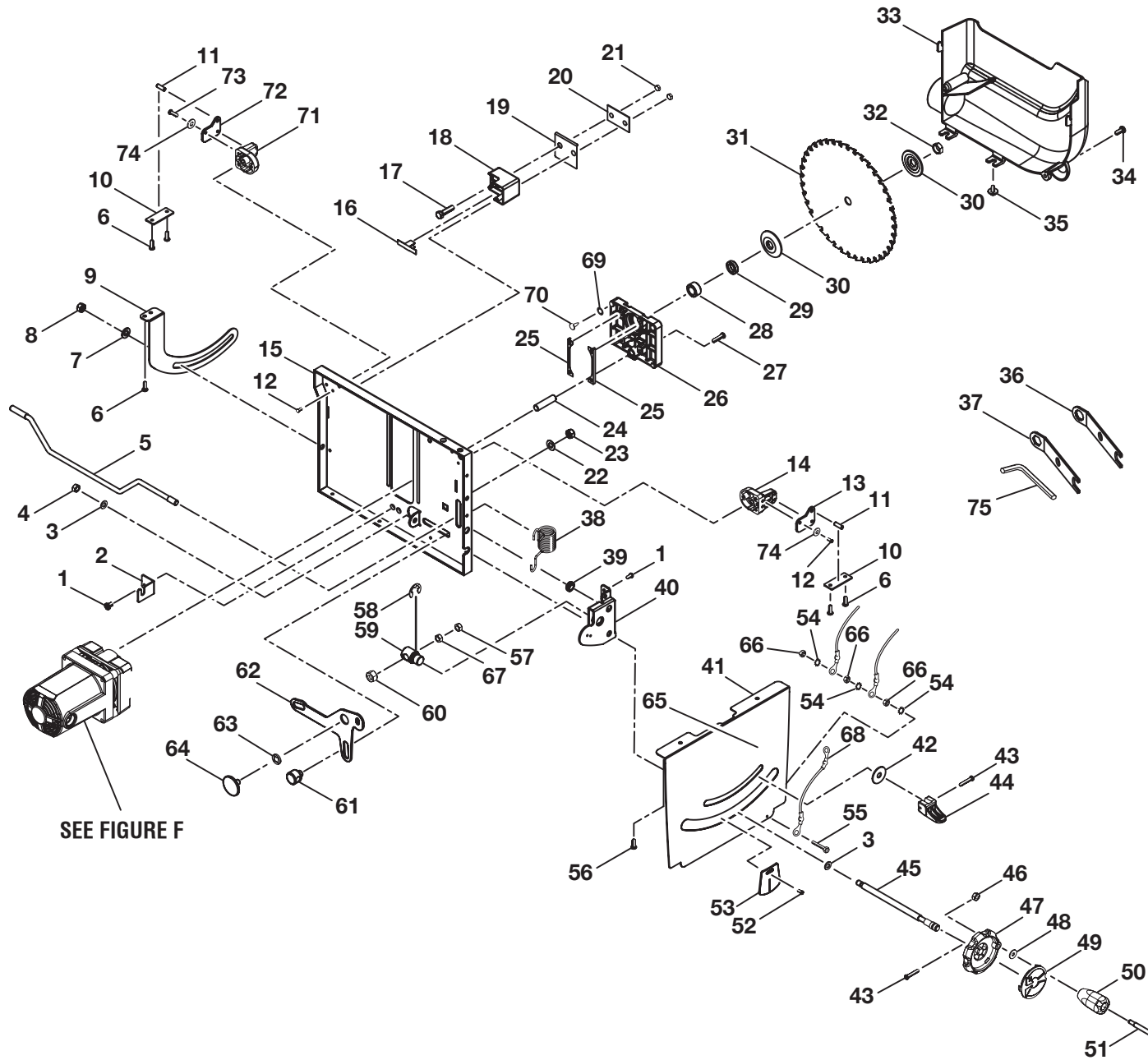

SEE FIGURE F

RYOBI 10 in. (254 mm) TABLE SAW - MODEL NO. BTS20R

The model number will be found on a plate attached to the motor housing. Always mention the model number in all correspondence regarding your **TABLE SAW** or when ordering repair parts.

PARTS LIST FOR FIGURE E

Key No.	Part Number	Description	Qty.	Key No.	Part Number	Description	Qty.
1	410132736	* SCREW (1/4-20 x 3/8 in.)	4	20	0181010321	RIVING CLAMP	1
2	0131010311	SUPPORTER	1	21	411011710	* HEX NUT (5/16-18)	2
3	412017051	* WASHER (D8 x D16 x 1.5T)	2	22	412012706	* WASHER (3/8 x 20 mm x 2T)	1
4	411011003	* HEX NUT (M8)	1	23	411072709	* NYLON NUT (3/8-16)	1
5	0131010905	CRANK	1	24	414050007	* PIN (12 x 25 mm)	1
6	410171706	* TAPPING SCREW (10-24 x 1/2 in.)	6	25	0131010302	SHIM	2
7	412012074	* WASHER (D10 x D26 x 2T)	1	26	0131010107	GEAR BOX	1
8	411072004	* NYLON NUT (M10)	1	27	0181010823	* SCREW AND WASHER (10-24 x 1 in.)	4
9	0131010308	REAR LINKAGE	1	28	0181010504	1/2 in. SPACER	1
10	0181010323	CLAMP PLATE	2	29	0181010503	1/4 in. SPACER	1
11	0181010905	NEEDLE ROLLER	2	30	0181010401	BLADE WASHER	2
12	410171706	* SCREW (10-24 x 1/2 in.)	10	31	422010040	BLADE (10 in. x 5/8 in. X 36T)	1
13	0181010312	PIVOT PLATE (FRONT)	1	32	0131010912	* ARBOR NUT (5/8-18)	1
14	0131010103	PIVOT SUPPORT (FRONT)	1	33	0131010205	DUST COVER	1
15	0131010306	LOCKER BRACKET	1	34	410131724	* SCREW (1/4-20 x 5/8 in.)	2
16	0181010320	FIX PLATE	1	35	410331703	* SCREW (1/4-20 x 5/8 in.)	2
17	410011718	* SCREW (5/16-18 x 1-1/4 in. HEX HD.)	2	36	0131010319	WRENCH (SMALL)	1
18	0131010106	RIVING KNIFE DECK	1	37	0131010318	WRENCH (LARGE)	1
19	0181010343	SHIM	5	38	0131010913	SPRING	1

WARNING: Improper repair of a double insulated tool can result in damage to the double insulation system possibly causing electrical shock or electrocution. Any repairs requiring disassembly of your tool requires safety testing and should only be performed by a Ryobi Authorized Service Center. For the service center nearest you call 1-800-525-2579.

* Standard Hardware Item – May Be Purchased Locally

RYOBI 10 in. (254 mm) TABLE SAW - MODEL NO. BTS20R

The model number will be found on a plate attached to the motor housing. Always mention the model number in all correspondence regarding your **TABLE SAW** or when ordering repair parts.

PARTS LIST FOR FIGURE E CONTINUED

Key No.	Part Number	Description	Qty.	Key No.	Part Number	Description	Qty.
39	0131010914	SPACER	1	58	413051008	C-CLIP (E-15)	1
40	0131010310	BRACKET	1	59	0131010906	BLOCK	1
41	0131010312-33	FRONT PANEL.....	1	60	0131010927	NUT	2
42	412012074	* WASHER (D10 x 26 x 2.0)	1	61	0131010301	DRIVE BLOCK	1
43	410132719	* SCREW (8-32 x 1-3/16 in.)	2	62	0131010305	DRIVE PLATE.....	1
44	0131010227	BEVEL LOCKER	1	63	0131010907	WASHER	1
45	0131010804	GEAR SHAFT (HEIGHT).....	1	64	0131010803	* SCREW (3/8-16 x 1/2 in.)	1
46	411072702	* LOCK NUT (1/4-20)	1	65	9131015330101	NAME PLATE (LOGO PLATE)	1
47	0131010206	HANDWHEEL	1	66	411011008	* HEX LOCK NUT (8-32 X 3/4)	3
48	412011712	* FLAT WASHER (1/4 x 13 x 1.5).....	1	67	411021001	* HEX NUT (M8)	1
49	0101140206	HANDWHEEL INSERT.....	1	68	0131011101	GROUNDING WIRE TO STAND	1
50	0131010208	WHEEL HANDLE	1	69	0131010238	WEAR PAD	4
51	0101140203	SPECIAL HANDWHEEL SCREW.....	1	70	0131010239	NYLON WASHER	4
52	410331008	* SCREW (M4 X 10 mm)	2	71	0131010111	PIVOT SUPPORT (REAR)	1
53	0131010215	BEVEL INDICATOR.....	1	72	0131010332	PIVOT PLATE (REAR)	1
54	412041002	* STAR WASHER (M4).....	3	73	410341001	* HEX SOCKET SCREW WITH WASHER (M5 X 16 mm)	2
55	0181010816	* SCREW (8-32 X 3/4 in.)	1	74	412011007	* FLAT WASHER (D5 x D12 x 1.5T).....	2
56	0181010814	* SCREW (10-24 x 1/2 in.).....	2	75	0181010925	HEX KEY (1/4 in.).....	1
57	411011003	* HEX NUT (M8)	2				

WARNING: Improper repair of a double insulated tool can result in damage to the double insulation system possibly causing electrical shock or electrocution. Any repairs requiring disassembly of your tool requires safety testing and should only be performed by a Ryobi Authorized Service Center. For the service center nearest you call 1-800-525-2579.

* Standard Hardware Item – May Be Purchased Locally

RYOBI 10 in. (254 mm) TABLE SAW - MODEL NO. BTS20R

FIGURE F

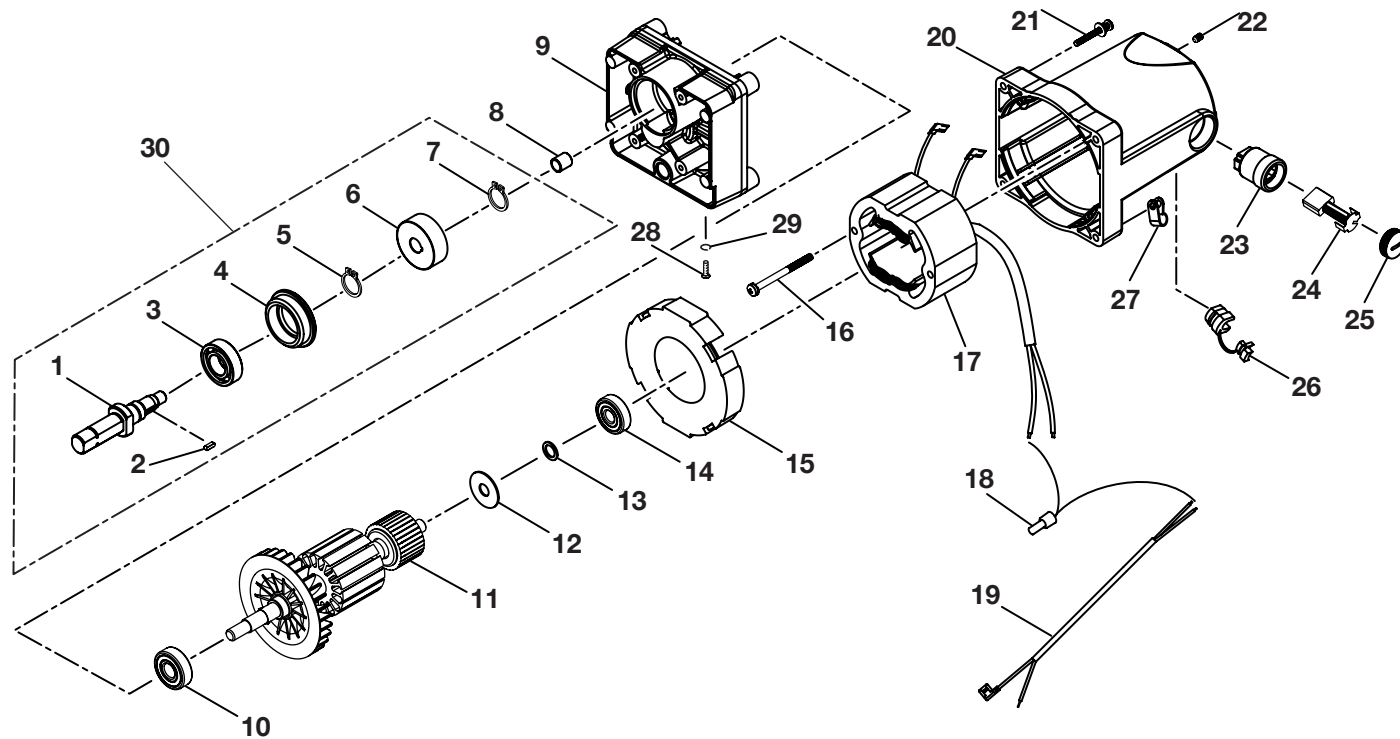

NOTE: The assembly shown represents an important part of the double insulated system. To avoid the possibility of alteration or damage to the system, service should be performed by your nearest Ryobi Authorized Service Center. For the service center nearest you call 1-800-525-2579.

RYOBI 10 in. (254 mm) TABLE SAW - MODEL NO. BTS20R

The model number will be found on a plate attached to the motor housing. Always mention the model number in all correspondence regarding your **TABLE SAW** or when ordering repair parts.

PARTS LIST FOR FIGURE F

Key No.	Part Number	Description	Qty.	Key No.	Part Number	Description	Qty.
	A131010101	COMPLETE MOTOR ASSEMBLY		17	A131010401	FIELD.....	1
1	0131010602	ARBOR	1	18	451020002	WIRE NUT	2
2	415030001	KEY (3 x 3 x 10 mm).....	1	19	0131010703	MOTOR WIRE.....	1
3	420010003	* BALL BEARING (6002LU, Z)	1	20	0131010201	MOTOR HOUSING	1
4	0101010505	BEARING BUSHING.....	1	21	410271701	* SCREW AND WASHER (3/16-32UNF x 1-3/8 in.).....	4
5	413011001	* C-CLIP (S15).....	1	22	410071004	* SET SCREW (M5 x 10 mm)	2
6	0131011001	REDUCTION GEAR	1	23	0502020221	BRUSH HOLDER ASSEMBLY	2
7	413011009	* C-CLIP (S13).....	1	24	0502025002	BRUSH ASSEMBLY	2
8	420110003	* NEEDLE BEARING (HK0910)	1	25	0602200209	BRUSH CAP	2
9	0131010101	GEAR BOX.....	1	26	451010003	STRAIN RELIEF	1
10	420010001	* BALL BEARING (6201LLU CM,5C)	1	27	0301030202	WIRE CLAMP (5/16 in.)	1
11	A131010301	ARMATURE ASSEMBLY.....	1	28	410131002	* SCREW (M4 x 8 mm).....	1
12	0181010344	INSULATION PLATE	1	29	412041002	* LOCK WASHER (M4).....	1
13	0181010307	INSULATION PLATE	1	30	A131010501	ARBOR SHAFT ASSEMBLY	1
14	420010004	* BALL BEARING (6200LU CM,5C)	1		983000-428	OPERATOR'S MANUAL	
15	0131010202	BAFFLE.....	1		983000-428R	REPAIR SHEET (REV:02)	
16	410462002	* SCREW AND STAR WASHER (M5 x 60 mm)2			05-03-05		

WARNING: Improper repair of a double insulated tool can result in damage to the double insulation system possibly causing electrical shock or electrocution. Any repairs requiring disassembly of your tool requires safety testing and should only be performed by a Ryobi Authorized Service Center. For the service center nearest you call 1-800-525-2579.

* Standard Hardware Item – May Be Purchased Locally

RYOBI 10 in. (254 mm) TABLE SAW - MODEL NO. BTS20R

FIGURE G

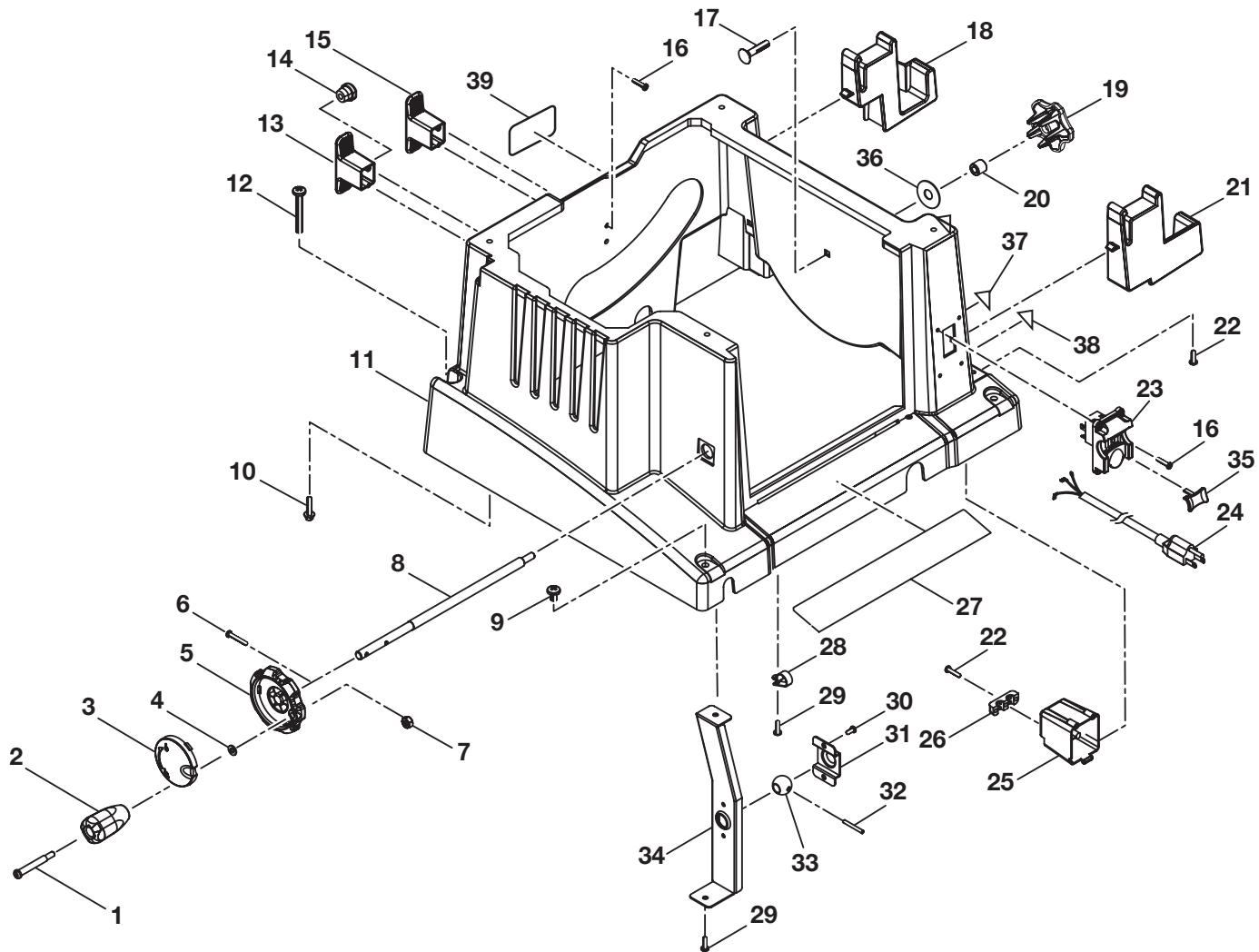

RYOBI 10 in. (254 mm) TABLE SAW - MODEL NO. BTS20R

The model number will be found on a plate attached to the motor housing. Always mention the model number in all correspondence regarding your **TABLE SAW** or when ordering repair parts.

PARTS LIST FOR FIGURE G

Key No.	Part Number	Description	Qty.	Key No.	Part Number	Description	Qty.
1	0101140203	HANDWHEEL BOLT	2	21	0131010211-39	FENCE HANGER (FRONT)	1
2	0131010208	HANDWHEEL HANDLE	1	22	410451703	* SCREW (8-16 x 3/4 in.).....	7
3	0131010207-35	BEVEL HANDWHEEL CAP	1	23	984406-001	SWITCH.....	1
4	412011712	* FLAT WASHER (1/4 x 13 x 1.5).....	1	24	0131010702	POWER CORD	1
5	0131010206	FRONT HANDWHEEL	1	25	0131010209	SWITCH BOX	1
6	410132719	* SCREW (8-32 x 1-3/16 in.)	1	26	0131010210	CORD CLAMP	1
7	411072702	* LOCK NUT (1/4-20)	1	27	9131015330201	WARNING LABEL.....	1
8	0131010805	SCREW ROD	1	28	0301030202	WIRE CLAMP (5/16)	4
9	0131010815	* TORQUE SCREW (5/16-18 x 1/2 in.).....	2	29	410451701	* SCREW (8-16 x 1/2 in.).....	5
10	410161004	* LOCK SCREW (M6 x 25 mm)	4	30	410132728	* SCREW (1/4-20 x 3/8 in.)	2
11	0131010203-39	CABINET	1	31	0131010328	PLATE	1
12	0131010816	* TORQUE SCREW (5/16-18 x 1-1/4 in.)	2	32	414011021	* SPRING PIN (M4 x 24 mm)	1
13	0131010217-39	CABLE MANAGEMENT (LEFT).....	1	33	0131010926	BALL.....	1
14	451010003	STRAIN RELIEF	1	34	0131010320	REINFORCE PLATE.....	1
15	0131010222-39	CABLE MANAGEMENT (RIGHT)	1	35	984406-003	SWITCH KEY	1
16	410191005	* SCREW (M4 x 20 mm PAN HD.).....	8	36	412015087	* WASHER (D11 x 26 x 2T)	1
17	410031710	* CARRIAGE BOLT (5/16-18 x 1-1/2 in.).....	1	37	9131015335706	LOCK LABEL.....	1
18	0131010212-39	FENCE HANGER (REAR).....	1	38	9131015335705	UNLOCK LABEL.....	1
19	0131010240	BLADE STORAGE KNOB	1	39	9131015333102	DATA PLATE (BTS20R)	1
20	0171010216	BLADE STORAGE SPACER	1				

WARNING: Improper repair of a double insulated tool can result in damage to the double insulation system possibly causing electrical shock or electrocution. Any repairs requiring disassembly of your tool requires safety testing and should only be performed by a Ryobi Authorized Service Center. For the service center nearest you call 1-800-525-2579.

* Standard Hardware Item – May Be Purchased Locally

RYOBI 10 in. (254 mm) TABLE SAW - MODEL NO. BTS20R

FIGURE H

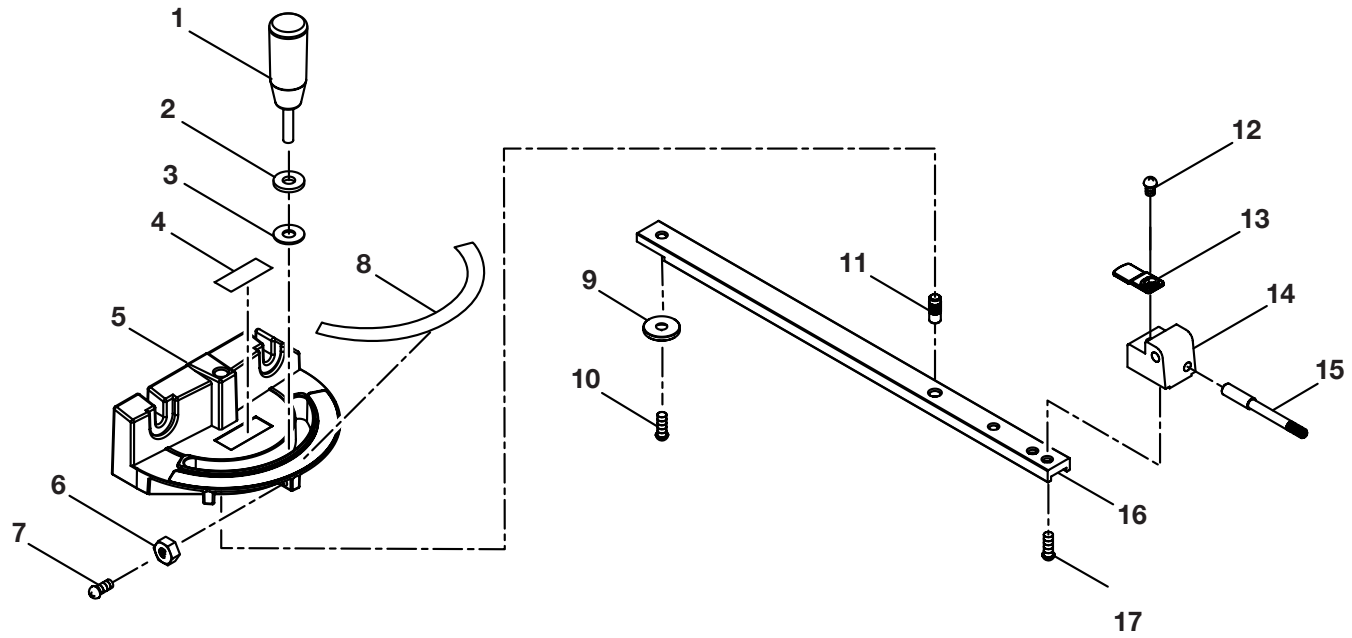

RYOBI 10 in. (254 mm) TABLE SAW - MODEL NO. BTS20R

The model number will be found on a plate attached to the motor housing. Always mention the model number in all correspondence regarding your **TABLE SAW** or when ordering repair parts.

PARTS LIST FOR FIGURE H

Key No.	Part Number	Description	Qty.
	A131010801	MITER GAUGE ASSEMBLY	
1	A131015202	KNOB.....	1
2	412012705	WASHER.....	1
3	412080702	NYLON WASHER	1
4	9131015330102	LOGO LABEL.....	1
5	0131010109-94	MITER GAUGE HEAD	1
6	411012704	HEX NUT	3
7	410132734	SCREW	3
8	9131015330304	MITER SCALE LABEL	1
9	0131010928	MITER SLIDER WASHER	1
10	410102014	* SCREW (M6 x 8 mm).....	1
11	0101010917	CENTER PIN.....	1
12	410332701	SCREW	1
13	0131010329	MITER INDICATOR	1
14	0131010110	INDICATOR DECK	1
15	0101010918	INDEX PIN	1
16	0131011807	BAR	1
17	410102701	SCREW	2

WARNING: Improper repair of a double insulated tool can result in damage to the double insulation system possibly causing electrical shock or electrocution. Any repairs requiring disassembly of your tool requires safety testing and should only be performed by a Ryobi Authorized Service Center. For the service center nearest you call 1-800-525-2579.

* Standard Hardware Item – May Be Purchased Locally

RYOBI 10 in. (254 mm) TABLE SAW - MODEL NO. BTS20R

The model number will be found on a plate attached to the motor housing. Always mention the model number in all correspondence regarding your **TABLE SAW** or when ordering repair parts.

PARTS LIST FOR FIGURE I

Key No.	Part Number	Description	Qty.	Key No.	Part Number	Description	Qty.
	A131011301	STAND ASSEMBLY		20	411071702	* HEX NUT (1/4 in.)	1
1	0131010234	WHEEL CAP	2	21	411011008	* HEX LOCK NUT (8-32)	2
2	0131010812	SHOULDER BOLT	2	22	412041002	* STAR WASHER (M4)	1
3	412011085	WASHER	4	23	0181010816	* SCREW (8-32 X 3/4 in.)	1
4	0131010235	8 in. WHEEL	2	24	410011722	* HEX SCREW (1/4-20 x 2 in.)	2
5	410491704	* HEX SCREW (5/16-18 X 57.2 mm)	2	25	0131010923	PIN	2
6	0131010233	CAP	2	26	0131010231	SLIDER	1
7	A131016302	REAR LEG	1	27	0131010916	TORSION SPRING	1
8	0131010917	REAR SPRING	1	28	A131016301	FRONT LEG	1
9	410131731	* SCREW (1/4-20 x 1/2 in.)	4	29	0131011304	HANDLE TUBE	1
10	0131011302	PAD	4	30	0131010918	ADJUST SPRING	1
11	0131010230	SLIDER	1	31	0131010232	ADJUST RING	1
12	A131017001	SLIDER FRAME	1	32	410031714	* CARRIAGE BOLT (5/8-11 x 88.9 mm)	1
13	412041702	* STAR WASHER (1/4 in.)	2	33	413061001	* C-CLIP (CTW46)	2
14	411011707	* HEX NUT (1/4 in.)	2	34	0131010813	LINKAGE ROD	1
15	0131010323-112	LATCH	1	35	0131011303	PAD	3
16	0131010810	SCREW	1	36	412011025	WASHER	4
17	0131011301	LATCH COVER	1	37	A131016303	SLIDE LEG	1
18	0131010322	LATCH BAR	1	38	0131010811	SCREW	2
19	0131010915	LATCH SPRING	1				

WARNING: Improper repair of a double insulated tool can result in damage to the double insulation system possibly causing electrical shock or electrocution. Any repairs requiring disassembly of your tool requires safety testing and should only be performed by a Ryobi Authorized Service Center. For the service center nearest you call 1-800-525-2579.

* Standard Hardware Item – May Be Purchased Locally

RYOBI 10 in. (254 mm) TABLE SAW - MODEL NO. BTS20R

The model number will be found on a plate attached to the motor housing. Always mention the model number in all correspondence regarding your **TABLE SAW** or when ordering repair parts.

PARTS LIST FOR FIGURE J

Key No.	Part Number	Description	Qty.	Key No.	Part Number	Description	Qty.
	A131010901	RIP FENCE ASSEMBLY		12	0133010217	SCALE INDICATOR	1
1	410139719	* NYLOCK SCREW (10-32 x 1 in.)	1	13	0131010213	SLIDER	2
2	0131010317	CLAMPER - B.....	1	14	410171716	* SCREW (8-32 x 9.5 mm)	2
3	0131010218	REAR DECK	1	15	0131010909	PIN.....	1
4	0131010908	PUSH ROD	1	16	0131010315	CLAMPER - A.....	1
5	414011023	ROLL PIN (D3.175 X 19.05 mm).....	1	17	0131010226	BLOCK	1
6	0181010907	COMPRESSION SPRING.....	1	18	0131010104-94	FRONT BLOCK.....	1
7	414050008	PIN (D6 X 33.7)	1	19	410195012	* SCREW (M3 x 8 mm).....	1
8	0131011801	RIP FENCE RAIL	1	20	0181010506	ECCENTRIC ROLLER.....	1
9	412011064	WASHER (D7 X D16 X 1.5T)	2	21	0181010227	FENCE LOCKING HANDLE/ AUXILLIARY HANDLE	1
10	410491703	* SCREW (1/4-20 x 5/8 in.)	2	22	414050010	PIN (D4)	1
11	410331008	* SCREW AND WASHER (M4 x 10 mm)	1				

WARNING: Improper repair of a double insulated tool can result in damage to the double insulation system possibly causing electrical shock or electrocution. Any repairs requiring disassembly of your tool requires safety testing and should only be performed by a Ryobi Authorized Service Center. For the service center nearest you call 1-800-525-2579.

* Standard Hardware Item – May Be Purchased Locally