

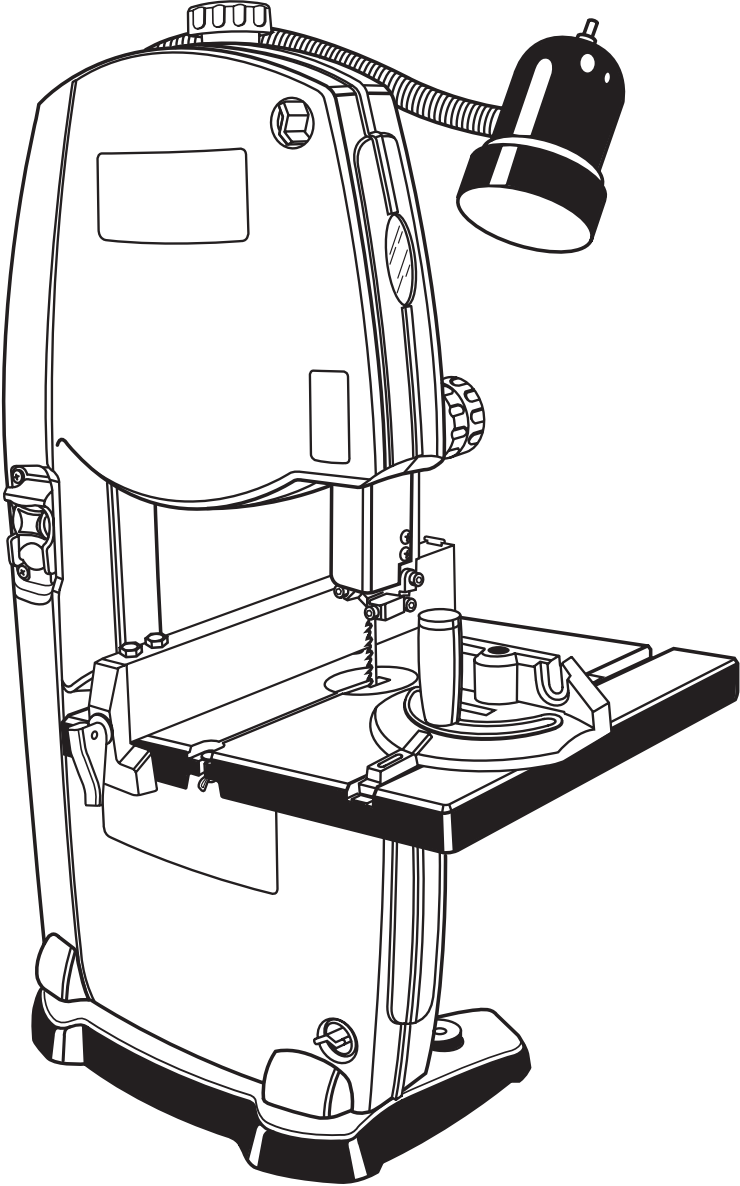

# OPERATOR'S MANUAL

## 9 in. (229 mm) BAND SAW

### BS902



Your new Band Saw has been engineered and manufactured to Ryobi's high standards for dependability, ease of operation, and operator safety. Properly cared for, it will give you years of rugged, trouble-free performance.

**WARNING:** To reduce the risk of injury, the user must read and understand the operator's manual before using this product.

Thank you for buying a Ryobi tool.

**SAVE THIS MANUAL FOR FUTURE REFERENCE**

# TABLE OF CONTENTS

■ Introduction .....	2
■ Rules for Safe Operation .....	3-5
■ Electrical .....	6
■ Glossary of Terms .....	7
■ Features .....	7-9
■ Unpacking .....	9
■ Tools Needed .....	10
■ Loose Parts List .....	10
■ Assembly .....	11-14
■ Operation .....	14-16
■ Adjustments .....	17-20
■ Maintenance .....	20-21
■ Troubleshooting .....	22
■ Parts Ordering / Service .....	24

## INTRODUCTION

### IMPORTANT

Servicing requires extreme care and knowledge and should be performed only by a qualified service technician. For service we suggest you return the tool to your nearest **RYOBI AUTHORIZED SERVICE CENTER** for repair. When servicing, use only identical Ryobi replacement parts.

### **WARNING:**

Do not attempt to use the tool until you read thoroughly and understand completely the operator's manual. Pay close attention to the safety rules, including Dangers, Warnings, and Cautions. If you use this tool properly and only for what it is intended, you will enjoy years of safe, reliable service.

### **WARNING:**





The operation of any power tool can result in foreign objects being thrown into your eyes, which can result in severe eye damage. Before beginning tool operation, always wear safety goggles or safety glasses with side shields and a full face shield when needed. We recommend Wide Vision Safety Mask for use over eyeglasses or standard safety glasses with side shields. Always wear eye protection which is marked to comply with ANSI Z87.1.



**Look for this symbol to point out important safety precautions. It means attention!!! Your safety is involved.**



# RULES FOR SAFE OPERATION

The purpose of safety symbols is to attract your attention to possible dangers. The safety symbols, and the explanations with them, deserve your careful attention and understanding. The safety warnings do not by themselves eliminate any danger. The instructions or warnings they give are not substitutes for proper accident prevention measures.

Symbol	Meaning
	<b>DANGER:</b> Indicates an imminently hazardous situation which, if not avoided, will result in death or serious injury.
	<b>WARNING:</b> Indicates a potentially hazardous situation which, if not avoided, could result in death or serious injury.
	<b>CAUTION:</b> Indicates a potentially hazardous situation which, if not avoided, may result in minor or moderate injury. It may also be used to alert against unsafe practices that may cause property damage.
<b>NOTE:</b>	Advises you of information or instructions vital to the operation or maintenance of the equipment.

## SAFETY AND INTERNATIONAL SYMBOLS

This operator's manual describes safety and international symbols and pictographs that may appear on this product. Read the operator's manual for complete safety, assembly, operating and maintenance, and repair information.

SYMBOL	MEANING
	<ul style="list-style-type: none"><li>• Do not expose to rain or use in damp locations.</li></ul>
	<b>NO HANDS SYMBOL</b> <ul style="list-style-type: none"><li>• Failure to keep your hands away from the blade will result in serious personal injury.</li></ul>

# RULES FOR SAFE OPERATION

Safe operation of this power tool requires that you read and understand this operator's manual and all labels affixed to the tool. Safety is a combination of common sense, staying alert, and knowing how your band saw works.

## READ ALL INSTRUCTIONS

- **KNOW YOUR POWER TOOL.** Read the operator's manual carefully. Learn the applications and limitations as well as specific potential hazards related to this tool.
- **GUARD AGAINST ELECTRICAL SHOCK** by preventing body contact with grounded surfaces. For example: pipes, radiators, ranges, refrigerator enclosures.
- **KEEP GUARDS IN PLACE** and in working order. Never operate the tool with any guard or cover removed. Make sure all guards are operating properly before each use.
- **REMOVE ADJUSTING KEYS AND WRENCHES.** Form habit of checking to see keys and adjusting wrenches are removed from tool before turning it on.
- **KEEP THE WORK AREA CLEAN.** Cluttered work areas and work benches invite accidents.
- **DON'T USE IN DANGEROUS ENVIRONMENTS.** Do not use power tools near gasoline or other flammable liquids, in damp or wet locations or expose them to rain. Keep work area well lighted.
- **KEEP CHILDREN AND VISITORS AWAY.** All visitors should wear safety glasses and be kept a safe distance from work area.
- **MAKE WORKSHOP CHILDPROOF** with padlocks, master switches, or by removing starter keys.
- **DON'T FORCE THE TOOL.** It will do the job better and safer at the rate for which it was designed.
- **USE THE RIGHT TOOL.** Do not force the tool or attachment to do a job for which it was not designed.
- **USE THE PROPER EXTENSION CORD.** Make sure your extension cord is in good condition. When using an extension cord, be sure to use one heavy enough to carry the current your product will draw. An undersized cord will cause a drop in line voltage resulting in loss of power and overheating. A wire gage size (A.W.G.) of at least **16** is recommended for an extension cord 25 feet or less in length. If in doubt, use the next heavier gage. The smaller the gage number, the heavier the cord.
- **WEAR PROPER APPAREL.** Do not wear loose clothing, neckties, or jewelry that can get caught in the tool's moving parts and cause personal injury. Nonslip footwear is recommended when working outdoors. Wear protective hair covering to contain long hair.
- **ALWAYS WEAR SAFETY GLASSES WITH SIDE SHIELDS.** Everyday eyeglasses have only impact-resistant lenses; they are **NOT** safety glasses.
- **SECURE WORK.** Use clamps or a vise to hold work when practical. It's safer than using your hand and it frees both hands to operate tool.
- **DO NOT OVERREACH.** Keep proper footing and balance at all times.
- **MAINTAIN TOOLS WITH CARE.** Keep tools sharp and clean for best and safest performance. Follow instructions for lubricating and changing accessories.
- **DISCONNECT ALL TOOLS.** When not in use, before servicing, or when changing attachments, blades, bits, cutters, etc., all tools should be disconnected from power source.
- **REDUCE THE RISK OF UNINTENTIONAL STARTING.** Be sure switch is off when plugging in.
- **USE RECOMMENDED ACCESSORIES.** Consult the operator's manual for recommended accessories. The use of improper accessories may cause risk of injury.
- **NEVER STAND ON TOOL.** Serious injury could occur if the tool is tipped or if the blade is unintentionally contacted.
- **CHECK DAMAGED PARTS.** Before further use of the tool, a guard or other part that is damaged should be carefully checked to determine that it will operate properly and perform its intended function. Check for alignment of moving parts, binding of moving parts, breakage of parts, mounting and any other conditions that may affect its operation. A guard or other part that is damaged must be properly repaired or replaced by an authorized service center to avoid risk of personal injury.
- **DIRECTION OF FEED.** Feed work into a blade or cutter against the direction or rotation of the blade or cutter only.
- **NEVER LEAVE TOOL RUNNING UNATTENDED. TURN POWER OFF.** Don't leave tool until it comes to a complete stop.
- **DON'T ABUSE CORD.** Never carry tool by the cord or yank it to disconnect from receptacle. Keep cord from heat, oil, and sharp edges.
- **PROTECT YOUR LUNGS.** Wear a face or dust mask if the cutting operation is dusty.
- **PROTECT YOUR HEARING.** Wear hearing protection during extended periods of operation.
- **BLADE COASTS AFTER TURN OFF.**
- **KEEP TOOL DRY, CLEAN, AND FREE FROM OIL AND GREASE.** Always use a clean cloth when cleaning. Never use brake fluids, gasoline, petroleum-based products, or any solvents to clean tool.
- **INSPECT TOOL CORDS AND EXTENSION CORDS PERIODICALLY** and, if damaged, have repaired by a qualified service technician. Stay constantly aware of cord location and keep it well away from the rotating wheel.
- **NEVER USE IN AN EXPLOSIVE ATMOSPHERE.** Normal sparking of the motor could ignite fumes.
- **USE ONLY OUTDOOR EXTENSION CORDS** with approved ground connection that are intended for use outdoors and so marked.
- **BE SURE THE BLADE PATH IS FREE OF NAILS.** Inspect for and remove nails from lumber before cutting.

# RULES FOR SAFE OPERATION

- **AVOID AWKWARD OPERATIONS AND HAND POSITIONS** where a sudden slip could cause your hand to move into the blade. **ALWAYS** make sure you have good balance.
- **ALLOW THE MOTOR TO COME UP TO FULL SPEED** before starting a cut to avoid binding or stalling.
- **DO NOT USE TOOL IF SWITCH DOES NOT TURN IT ON AND OFF.** Have defective switches replaced by an authorized service center.
- **REPLACEMENT PARTS.** All repairs, whether electrical or mechanical, should be made by a qualified service technician at an authorized service center.
- **WHEN SERVICING** use only identical Ryobi replacement parts. Use of any other parts may create a hazard or cause product damage.
- **KEEP HANDS AWAY FROM CUTTING AREA.** Do not hand hold pieces so small that your fingers go under the blade guard. Do not reach underneath work or in blade cutting path with your hands and fingers for any reason.
- **NEVER CUT MORE THAN ONE PIECE AT A TIME** or stack more than one workpiece on the saw table at a time.
- **FIRMLY CLAMP OR BOLT** your saw to a stable, level workbench or table. The most comfortable table height is approximately waist height.
- **DO NOT FEED THE MATERIAL TOO QUICKLY.** Do not force the workpiece against the blade.
- **USE ONLY CORRECT BLADES.** Use the right blade size, style and cutting speed for the material and the type of cut. Blade teeth should point down toward the table.
- **BEFORE MAKING A CUT, BE SURE ALL ADJUSTMENTS ARE SECURE.**
- **ALWAYS SUPPORT LARGE WORKPIECES** while cutting to minimize risk of blade pinching and kickback. Saw may slip, walk or slide while cutting large or heavy boards.
- **DO NOT REMOVE JAMMED CUTOFF PIECES** until blade has stopped.
- **NEVER START THE TOOL** when the blade is in contact with the workpiece.
- **NEVER TOUCH BLADE** or other moving parts during use.
- **BEFORE CHANGING THE SETUP, REMOVING COVERS, GUARDS OR BLADES,** unplug the saw and remove the switch key.
- **HOLD THE WORKPIECE** firmly against the saw table.
- **TO AVOID ACCIDENTAL BLADE CONTACT,** minimize blade breakage, and provide maximum blade support, always adjust the blade guide assembly to just clear the workpiece.
- **KEEP BLADES CLEAN, SHARP, AND WITH SUFFICIENT SET.** Sharp blades minimize stalling and kickbacks.
- **ALWAYS TURN OFF SAW** before disconnecting it to avoid accidental starting when reconnecting to a power source.
- **DO NOT OPERATE THIS TOOL WHILE UNDER THE INFLUENCE OF DRUGS, ALCOHOL OR ANY MEDICATION.**
- **STAY ALERT AND EXERCISE CONTROL.** Watch what you are doing and use common sense. **Do not** operate tool when you are tired. **Do not rush.**
- **MAKE SURE WORK AREA HAS AMPLE LIGHTING** to see the work and that no obstructions will interfere with safe operation **BEFORE** performing any work using your saw.
- The blade guides have been preset at the factory. These settings are functional for some applications. We recommend that you check and adjust blade guide settings before first use of your saw. Refer to “**Adjusting thrust bearings, blade guide support, and blade guides**” procedures explained in the *adjustments* section of this operator’s manual.
- **SAVE THESE INSTRUCTIONS.** Refer to them frequently and use them to instruct other users. If you loan someone this tool, loan them these instructions also.

## **WARNING:**

Some dust created by power sanding, sawing, grinding, drilling, and other construction activities contains chemicals known to cause cancer, birth defects or other reproductive harm. Some examples of these chemicals are:

- lead from lead-based paints,
- crystalline silica from bricks and cement and other masonry products, and
- arsenic and chromium from chemically-treated lumber.

Your risk from these exposures varies, depending on how often you do this type of work. To reduce your exposure to these chemicals, work in a well ventilated area, and work with approved safety equipment, such as those dust masks that are specially designed to filter out microscopic particles.

## SAVE THESE INSTRUCTIONS

# ELECTRICAL

## EXTENSION CORDS

Use only 3-wire extension cords that have 3-prong grounding plugs and 3-pole receptacles that accept the tool's plug. When using a power tool at a considerable distance from the power source, use an extension cord heavy enough to carry the current that the tool will draw. An undersized extension cord will cause a drop in line voltage resulting in a loss of power and causing the motor to overheat. Use the chart provided below to determine the minimum wire size required in an extension cord. Only round jacketed cords listed by Underwriter's Laboratories (UL) should be used.

Length of Extension Cord	Wire Size (A.W.G.)
Up to 25 feet	16
26-50 feet	16
51-100 feet	16

When working with the tool outdoors, use an extension cord that is designed for outside use. This is indicated by the letters **WA** on the cord's jacket.

Before using an extension cord, inspect it for loose or exposed wires and cut or worn insulation.

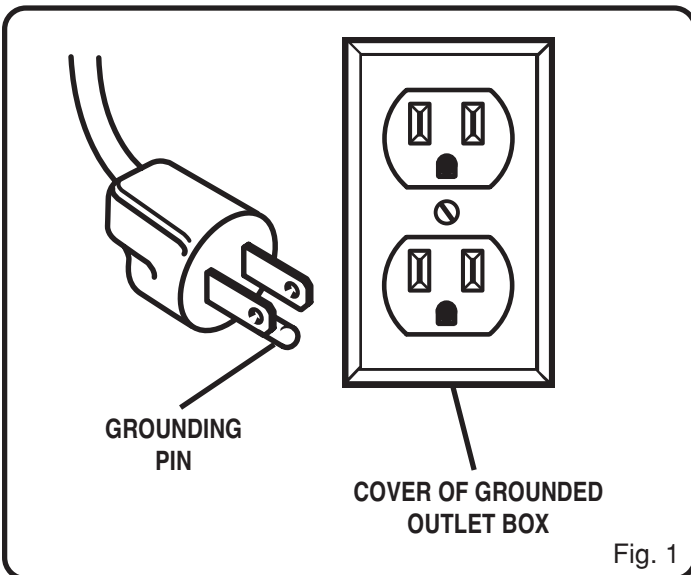

## ELECTRICAL CONNECTION

Your band saw is powered by a precision built electric motor. It should be connected to a **power supply that is 120 volts, 60Hz, AC only (normal household current)**. Do not operate this tool on direct current (DC). A substantial voltage drop will cause a loss of power and the motor will overheat. If the machine does not operate when plugged into an outlet, double check the power supply.

### ⚠ CAUTION:

Keep the cord away from the cutting area and position the cord so that it will not be caught on materials, tools, or other objects during cutting.

## GROUNDING INSTRUCTIONS

In the event of a malfunction or breakdown, grounding provides a path of least resistance for electric current to reduce the risk of electric shock. This tool is equipped with an electric cord having an equipment-grounding conductor and a grounding plug. The plug must be plugged into a matching outlet that is properly installed and grounded in accordance with all local codes and ordinances.

Do not modify the plug provided. If it will not fit the outlet, have the proper outlet installed by a qualified electrician. Improper connection of the equipment-grounding conductor can result in a risk of electric shock. The conductor, with insulation having an outer surface that is green with or without yellow stripes, is the equipment-grounding conductor. If repair or replacement of the electric cord or plug is necessary, do not connect the equipment-grounding conductor to a live terminal.

Check with a qualified electrician or service personnel if the grounding instructions are not completely understood, or if in doubt as to whether the tool is properly grounded.

Repair or replace a damaged or worn cord immediately.

This tool is intended for use on a circuit that has an outlet like the one shown in *Figure 1*. It also has a grounding pin like the one shown.

# GLOSSARY OF TERMS FOR WOODWORKING

## Bevel Cut

A cutting operation made with the saw table at any angle other than 90° to the blade.

## Compound Cut

A compound cut is a cut made using a miter angle and a bevel angle at the same time.

## Crosscut

A cutting or shaping operation made across the grain or the width of the workpiece.

## Freehand (for band saw)

Performing a cut without the workpiece properly supported on the saw table.

## Gum

A sticky, sap-based residue from wood products.

## Kerf

The material removed by the blade in a through cut or the slot produced by the blade in a non-through cut or partial cut.

## Kickback

A hazard that can occur when the blade binds or stalls, throwing the workpiece back toward operator.

## Leading End

The end of the workpiece pushed into the cutting tool first.

## Miter Cut

A cutting operation made with the workpiece at any angle to the blade other than 90°.

## Push Stick

A device used to feed the workpiece through the saw blade during narrow cutting operations. It helps keep the operator's hands well away from the blade.

## Resaw

A cutting operation to reduce the thickness of the workpiece to make thinner pieces.

## Resin

A sticky, sap-based substance that has hardened.

## Ripping

A cutting operation along the length of the workpiece.

## Saw Blade Path

The area directly in line — over, under, behind or in front of the blade. As it applies to the workpiece, that area which will be or has been cut by the blade.

## Set

The distance that the tip of the saw blade tooth is bent (or set) outward from the face of the blade.

## SFPM

3,000 surface feet per minute, used in reference to surface speed of blade.

## Throw-Back

Saw throwing back a workpiece in a manner similar to a kickback. Usually associated with a cause other than the kerf closing, such as a workpiece being dropped into the blade or being placed inadvertently in contact with the blade.

## Through Sawing

Any cutting operation where the blade extends completely through the thickness of the workpiece.

## Workpiece

The item on which the cutting operation is being done. The surfaces of a workpiece are commonly referred to as faces, ends, and edges.

## Worktable

The surface on which the workpiece rests while performing a cutting or sanding operation.

## FEATURES

### PRODUCT SPECIFICATIONS:

Blade Width	1/8 in. to 3/8 in. (3 mm to 10 mm)	Input Rating	2.5 Amperes 120 Volt, 60Hz AC Only
Blade Length	59-1/4 - 59-1/2 in. (1505mm - 1511mm)	No Load Speed	3,000 SFPM
Frame to Blade Capacity	9 in. (229 mm)	Net Weight	37 lbs. (17.8 kg)
Cutting Thickness Capacity	3-5/8 in. (92.07 mm)	Dust Port	2-1/4 in. (57.15 mm)
Table Size	11-13/16 in. x 11-13/16 in. (30 cm x 30 cm)		

# FEATURES

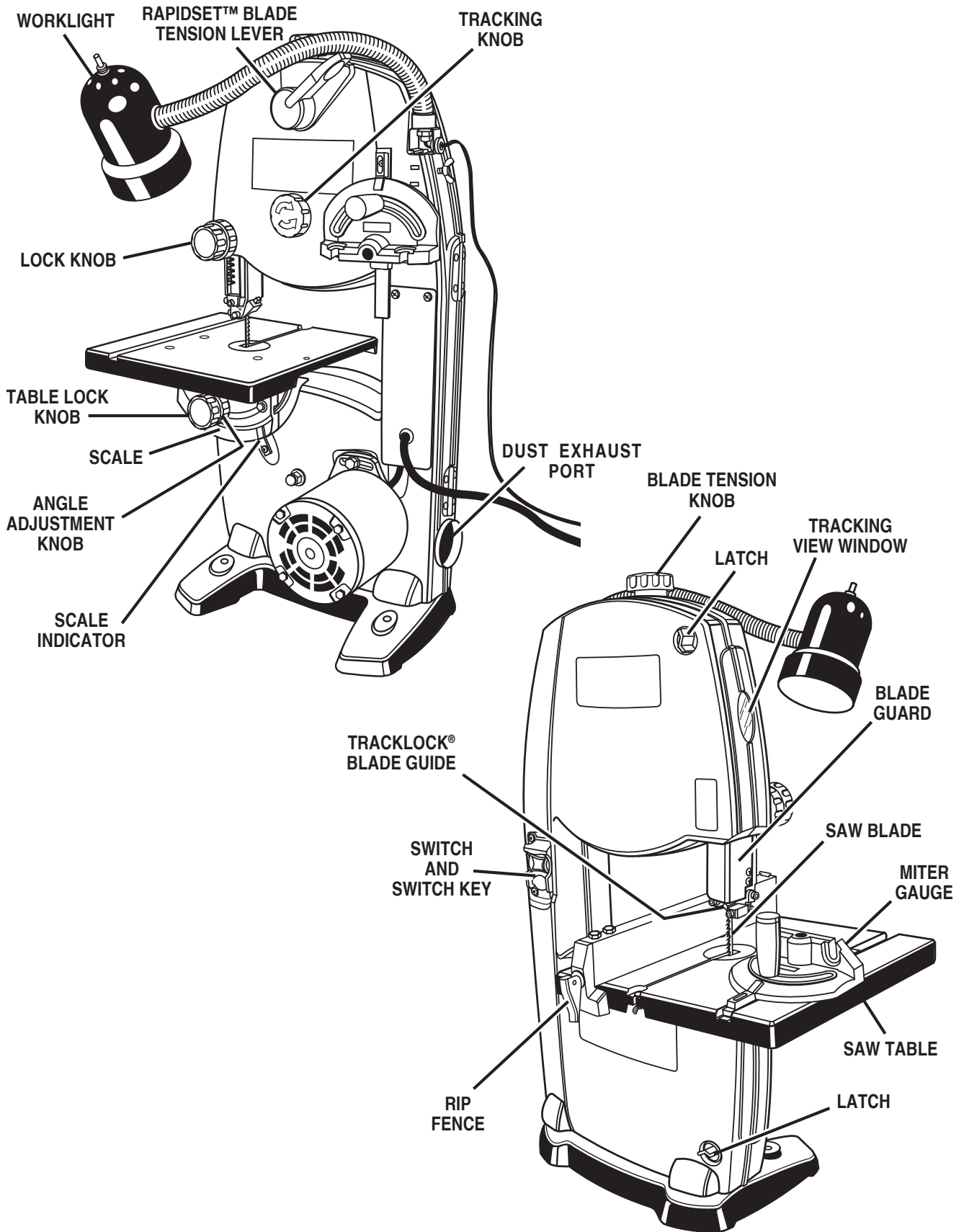

Fig. 2



# FEATURES

## KNOW YOUR BAND SAW

Before attempting to use, familiarize yourself with all the operating features and safety requirements of your saw.

### Angle Adjustment Knob

Tilts the saw table for bevel cutting.

### Blade Guard

Protects the operator from coming in contact with the blade.

### Blade Guide Knob with Lock Lever

Use the blade guide knob and lock lever to adjust the blade guide assembly to keep the blade from twisting or breaking. Always lock the blade guide assembly in place before turning on the band saw.

### Dust Exhaust Port

A 2-1/4 in. (57.15 mm) dust exhaust port makes dustless cutting possible by blowing the dust away from the user. Attach to the dust exhaust port when using a dust collection system or shop vac.

### Latch

Easy open latches allow front cover to be opened for making adjustments.

### Miter Gauge

This gauge aligns the wood for a crosscut. The easy-to-read indicator shows the exact angle for a miter cut, with positive stops at 90° and 45°.

### RapidSet™ Blade Tension Lever

Controls blade tension when changing blades and making adjustments for various sawing applications.

### Rip Fence

A sturdy metal fence guides the workpiece and is secured with the rip fence handle.

### Saw Blade

Saw comes with a standard 1/4 in. (6 mm) blade.

### Saw Table with Throat Plate

Your band saw has a square 11-13/16 in. (30 cm) aluminum saw table with tilt control for maximum accuracy. The throat plate, installed in the saw table at the factory, allows for blade clearance.

### Scale and Scale Indicator

The scale and scale indicator show the angle or degree the saw table is tilted for bevel cutting.

### Switch and Switch Key

Your band saw has an easy access power switch. To lock in the **OFF** position, remove the yellow switch key. Place the key in a location inaccessible to children and others not qualified to use the tool.

### Table Lock Knob

Loosening the table lock knob allows the saw table to be tilted at different angles. Tightening the table lock knob locks the saw table in place.

### Tracking Knob

Adjusts tracking to keep blade centered on the wheels.

### Tracking View Window

The tracking view window makes tracking adjustments easier to see.

### TrackLock® Blade Guides

Upper and lower TrackLock® blade guides help keep the blade from twisting during operation.

### Worklight

Your band saw comes equipped with a worklight that lights the work area for safer, more accurate cuts.

# UNPACKING

## **WARNING:**

To prevent accidental starting that could cause possible serious personal injury, assemble all parts to your saw before connecting it to power supply. Saw should never be connected to power supply when you are assembling parts, making adjustments, installing or removing blades, or when not in use.

- Carefully remove all parts from the carton and place the saw on a level work surface. Separate and check against the list of loose parts.

## **WARNING:**

If any parts are missing, do not operate this tool until the missing parts are replaced. Failure to do so could result in possible serious personal injury.

- Do not discard the packing materials until you have carefully inspected the saw, identified all parts, and satisfactorily operated your new saw.

**NOTE:** If any parts are damaged or missing, do not attempt to plug in the power cord and turn the switch on until the damaged or missing parts are obtained and are installed correctly.

# TOOLS NEEDED

The following tools (not included) are needed for checking adjustments of your saw or for installing the blade:

- Combination Square
- Phillips Screwdriver

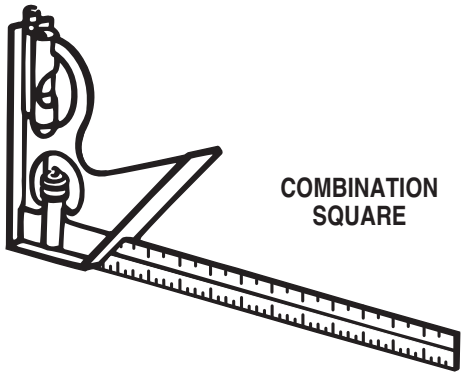

Fig. 3

# LOOSE PARTS LIST

Check all loose parts from the box with the list below. Assemble according to the instructions on the following pages.

Hex Key, 4 mm .....	1	Table Aligning Bolt .....	1
Rip Fence .....	1	Flat Head Screw .....	3
Miter Gauge .....	1	Worklight .....	1
Saw Table .....	1	Washer .....	1
Wing Screw .....	1	Switch Key .....	1
Wing Nut .....	1	Operator's Manual (not shown) .....	1

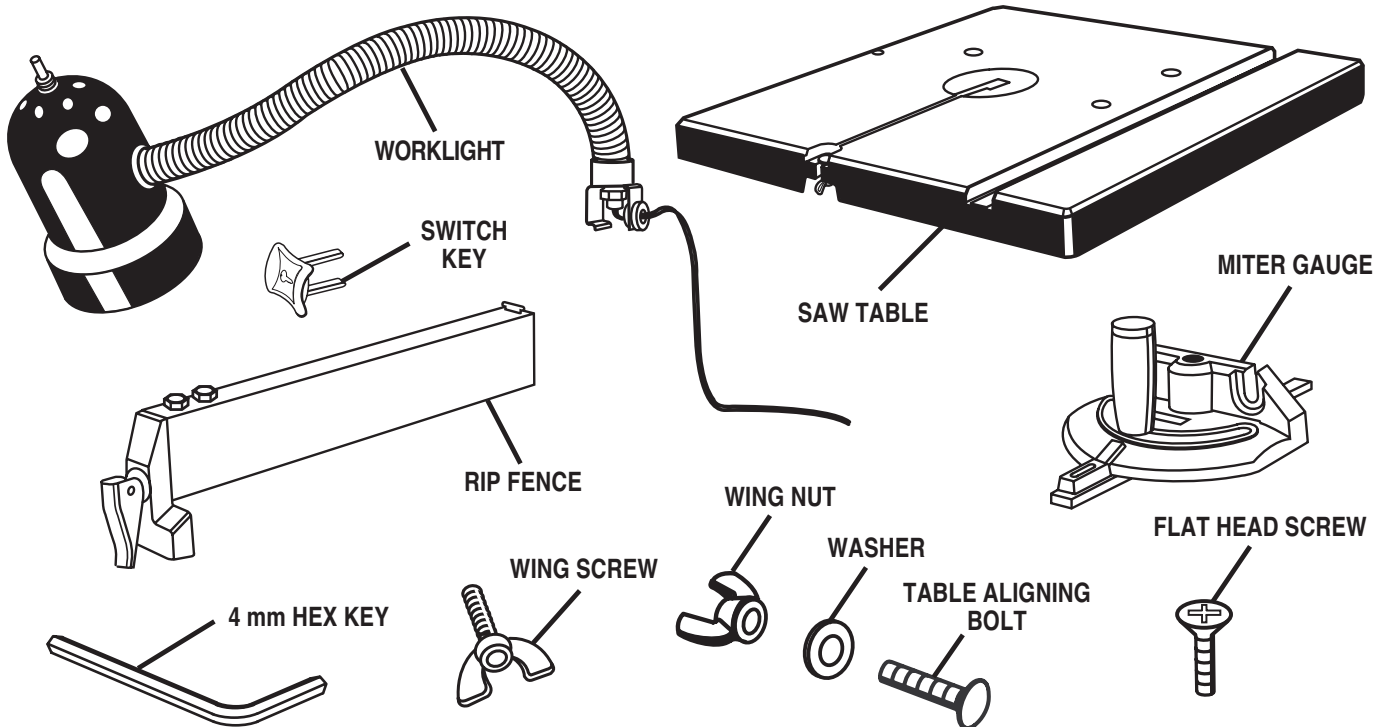

Fig. 4

# ASSEMBLY

## MOUNTING BAND SAW TO WORKBENCH

If the band saw is to be used in a permanent location, we recommend that you secure it to a workbench or other stable surface. When mounting the saw to a workbench, holes should be drilled through the supporting surface of the workbench.

- Each hole in the saw base should be bolted securely using bolts, lock washers, and hex nuts (not included).
- Place band saw on the workbench. Using the saw base as a pattern, locate and mark the holes where the band saw is to be mounted.
- Drill holes through the workbench.
- Place band saw on the workbench aligning holes in the saw base with the holes drilled in the workbench.
- Insert bolts (not included) and tighten securely with lock washers and hex nuts (not included).

**NOTE:** All bolts should be inserted from the top. Install the lock washers and hex nuts from the underside of the bench.

Supporting surface where band saw is mounted should be examined carefully after mounting to insure that no movement during use can result. If any tipping or walking is noted, secure workbench or support surface before beginning cutting operation.

## CLAMPING BAND SAW TO WORKBENCH

See Figure 5.

If the band saw is to be used as a portable tool, it is recommended that you fasten it permanently to a mounting board that can easily be clamped to a workbench or other supporting surface. The mounting board should be of sufficient size to avoid tipping of saw while in use. Any good grade plywood or chipboard with a 3/4 in. (19 mm) thickness is recommended.

- Mount saw to board using holes in saw base as a template for hole pattern. Locate and mark the holes where the band saw is to be mounted.
- Follow the last three steps in the section **Mounting Band Saw to Workbench**, shown above.

If lag bolts are used, make sure they are long enough to go through holes in the saw base and material the saw is being mounted to. If machine bolts are being used, make sure bolts are long enough to go through holes in the saw base, the material being mounted to, and the lock washers and hex nuts.

**NOTE:** It may be necessary to countersink hex nuts and washers on bottom side of mounting board.

## MOUNTING THE SAW TABLE

See Figures 6 and 7.

- Standing at the front of the band saw, slide the saw table pass the blade and through the slot moving from the right side of the saw table to the left.

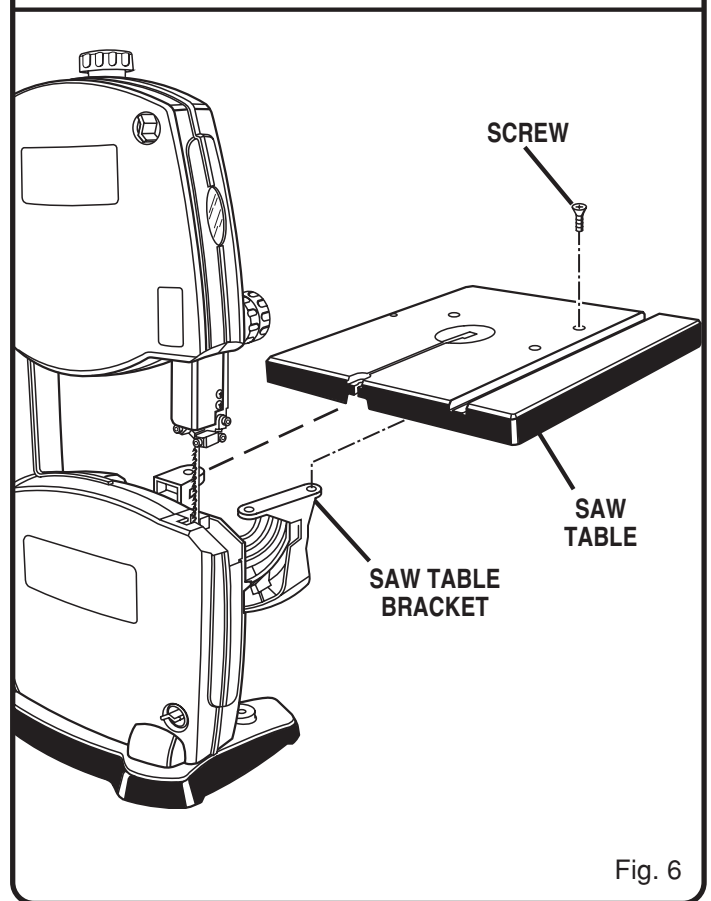
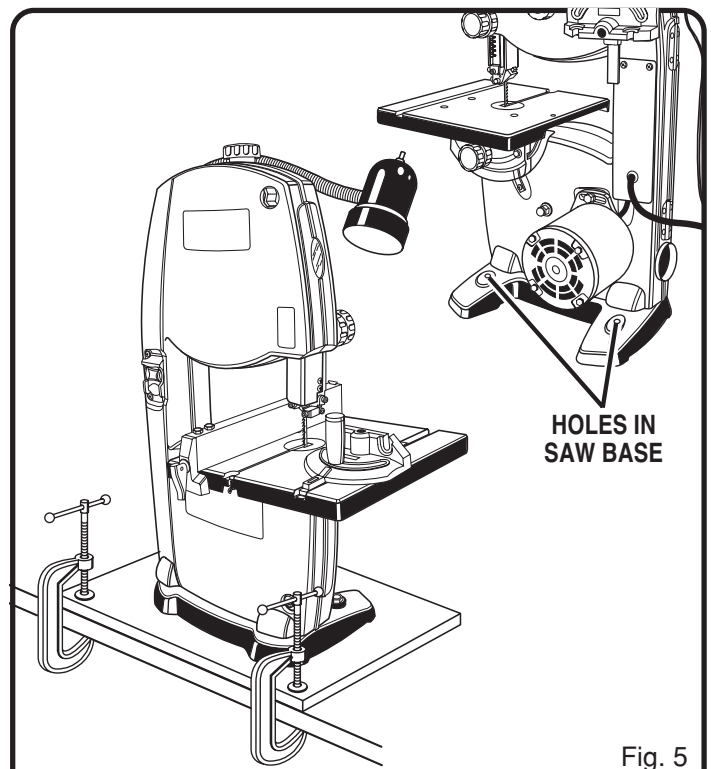

# ASSEMBLY

- Align the screw holes in the saw table with the holes in the saw table bracket.
- Using the phillips screws, attach the saw table to the saw table bracket. Tighten phillips screws securely.
- Attach the table aligning bolt, washer, and wing nut to the saw table.

**NOTE:** The wing nut goes below the saw table.

## SQUARING THE SAW TABLE TO THE BLADE

See Figure 8.

### **⚠ WARNING:**

Failure to turn the saw off, remove the switch key, and unplug the saw could result in accidental starting causing possible serious personal injury.

- Turn the lock knob counterclockwise to unlock the blade guide assembly. Turning the blade guide knob clockwise, raise the blade guide assembly as far as it will go. Turn the lock knob clockwise to retighten.
- Place a small combination square on the saw table beside the blade.
- Loosen the table lock knob and rotate the angle adjustment knob to tilt the saw table up or down to align table 90° to blade (0° position). Retighten the table lock knob.
- Using a hex key, adjust the zero stop set screw until the set screw just touches the saw housing.
- Check squareness of the saw table to the blade. Make readjustments if necessary.
- Loosen screw on scale indicator with a phillips screwdriver and align scale indicator to zero.
- Tighten all screws securely.

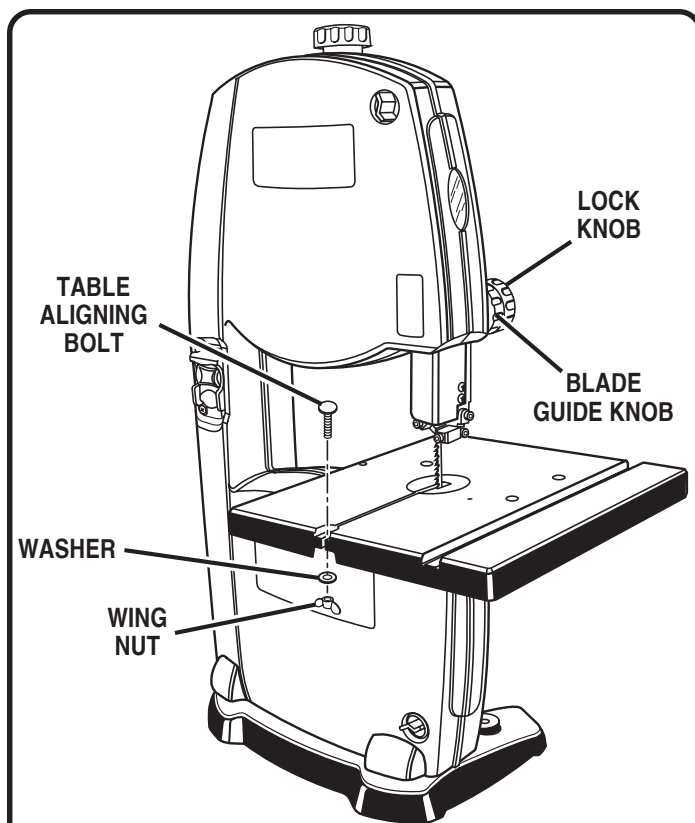

Fig. 7

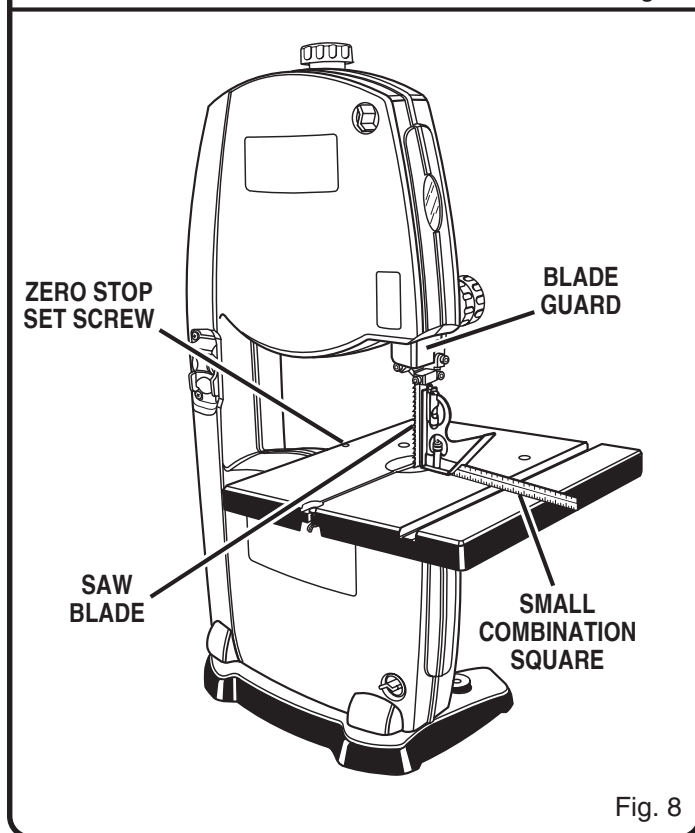

Fig. 8

# ASSEMBLY

## ADJUSTING BLADE TENSION

See Figures 9 and 10.

- Turn off and unplug the saw. Remove the switch key.

### **WARNING:**

Failure to turn the saw off, remove the switch key, and unplug the saw could result in accidental starting causing possible serious personal injury.

- Before using the band saw, turn the blade tension knob on the top of the saw clockwise to engage tension. See Figure 9.

**NOTE:** Adjustments of blade tension can be made at anytime.

Another method of checking blade tension has to do with the sound the blade makes when plucked like a guitar string.

- Pluck the back straight edge on the coasting side opposite the blade guides while turning the tension knob. Sound should be a musical note. Sound becomes higher pitched as tension increases.

Using either method to check blade tension can be developed with practice.

- Never increase blade tension so tight as to completely compress the spring. When completely compressed, the spring can no longer act as a shock absorber.

**NOTE:** Too much tension may cause the blade to break. Too little tension may cause the blade to slip on the wheels.

## TRACKING THE BLADE

See Figure 10.

### **WARNING:**

Failure to turn the saw off, remove the switch key, and unplug the saw could result in accidental starting causing possible serious personal injury.

**NOTE:** Adjust blade tension properly before making tracking adjustments. Check that the blade guides are not interfering with the blade.

### To Adjust:

- Open the front cover by releasing the upper and lower latches. Watch the blade's position on the upper tire through the tracking view window as, by hand, you slowly turn the upper wheel clockwise. If the blade moves away from the center of the tire, the tracking must be adjusted. Retighten hex nut.

### If the blade has moved left or right of center:

**NOTE:** It may be necessary to loosen the hex nut for a larger range of adjustments. Be sure to retighten after adjusting.

- Turn the blade tracking knob (clockwise if blade has moved left and counterclockwise if blade has moved right) while turning the wheel by hand until the blade moves back and rides in the center of the tire.

- Check the position of the blade on the lower tire. The blade should be completely on the tire. If not, adjust the tracking until the blade is on both tires.
- Rotate the upper wheel by hand in a clockwise direction for a few more turns. Make sure the blade stays in the same location on the tires. Readjust, if necessary, until blade is tracking properly.
- Close front cover and relatch.

**NOTE:** The 1/8 in. (3 mm) blade may not track properly in the center of the wheel. It may be better to track this blade on the back half of the upper wheel.

TO DECREASE  
TENSION

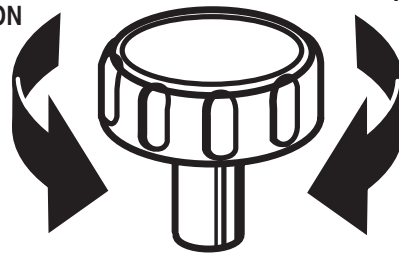

TO INCREASE  
TENSION

BLADE TENSION KNOB

Fig. 9

BLADE ON  
WHEEL

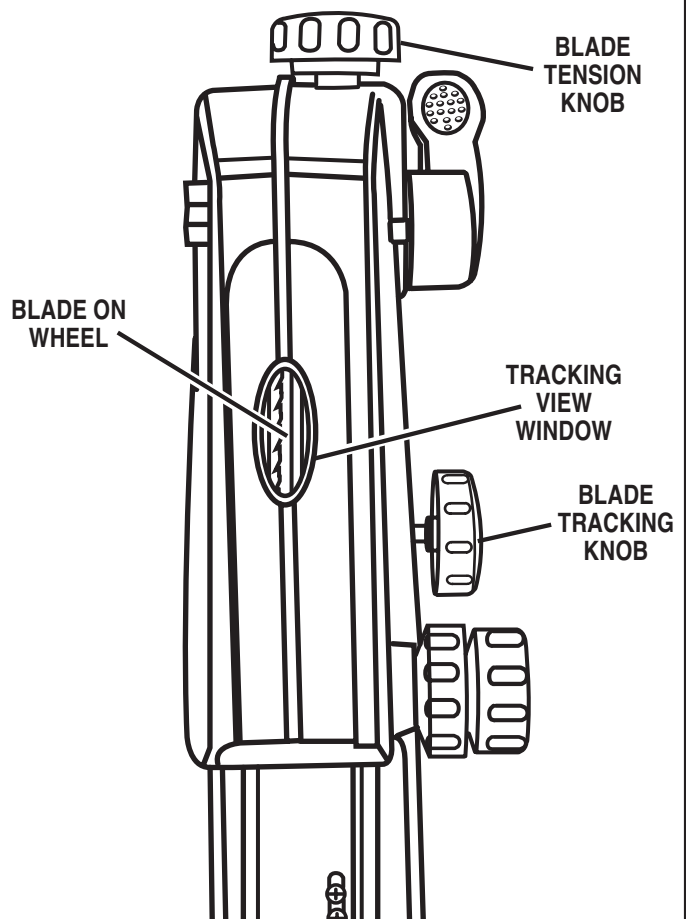

BLADE  
TENSION  
KNOB

TRACKING  
VIEW  
WINDOW

BLADE  
TRACKING  
KNOB

Fig. 10

# ASSEMBLY

## ATTACHING THE WORKLIGHT

See Figure 11.

### **WARNING:**

Failure to turn the saw off, remove the switch key, and unplug the saw could result in accidental starting causing possible serious personal injury.

- Open the cover of the saw housing.
- Slide the worklight bracket into the slot at the back of the band saw housing and into the slots on the inside of the band saw.
- Securely tighten the wing screw clockwise to hold the worklight firmly in place.
- Close the saw housing cover.

### IMPORTANT SAFETY INSTRUCTIONS

This worklight has a polarized plug (one blade wider than the other) as a feature to reduce the risk of electric shock. This plug will fit in a polarized outlet only one way. If the plug does not fit fully in the outlet, reverse the plug. If it still does not fit, contact a qualified electrician. Never use with an extension cord unless the plug can be fully inserted. Do not alter the plug.

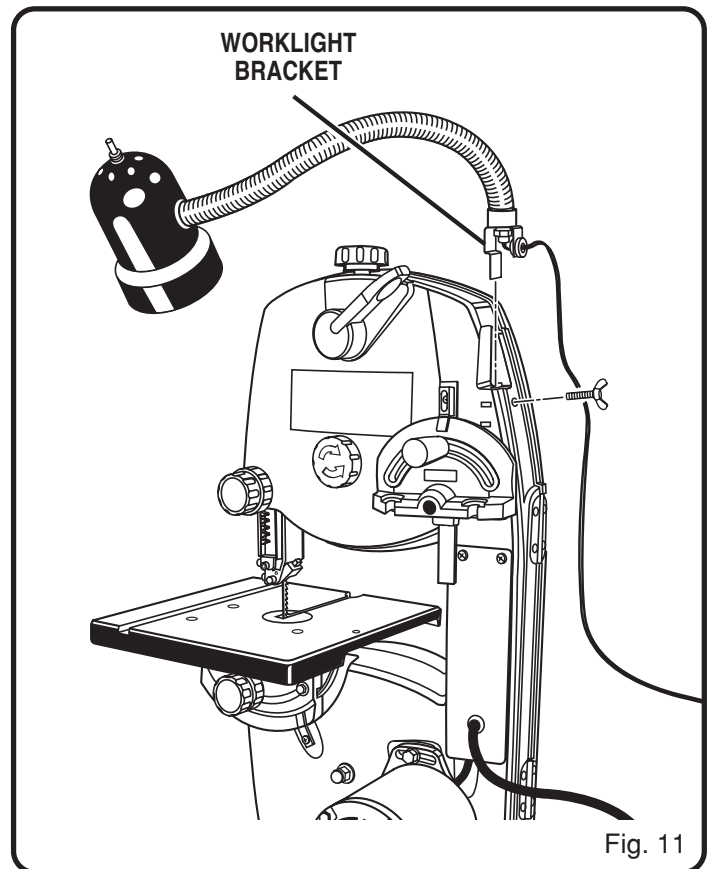

# OPERATION

### **WARNING:**

**Read and understand all instructions.** Failure to follow all instructions may result in electric shock, fire, and/or serious personal injury.

### **WARNING:**

To avoid blade contact, adjust the blade guide assembly to just clear the workpiece. Failure to do so could result in serious personal injury.

### BASIC OPERATION OF THE BAND SAW

A band saw is basically a “curve cutting” machine that can also be used for straight-line cutting operations like cross cutting, ripping, mitering, beveling, compound cutting, and resawing. It is not capable of making inside or non-through cuts.

This band saw is designed to cut wood and wood composition products only.

Before starting a cut, watch the saw run. If you experience excessive vibration or unusual noise, stop immediately. Turn the saw off, remove the switch key, and unplug the saw. Do not restart until locating and correcting the problem.

### CUTTING PROCEDURES

- Hold the workpiece firmly against the saw table.
- Use gentle pressure and both hands when feeding the work into the blade. Do **not** force the work; allow the blade to cut.
- The smallest diameter circle that can be cut is determined by blade width. A 1/4 in. (6 mm) wide blade will cut a minimum diameter of 1-1/2 in. (38 mm); a 1/8 in. (3 mm) wide blade will cut a minimum diameter of 1/2 in. (13 mm).
- Keep your hands away from the blade. Do not hand hold pieces so small your fingers will go under the blade guard.
- Avoid awkward operations and hand positions where a sudden slip could cause serious injury from contact with the blade. Never place hands in blade path.
- Use extra supports (tables, saw horses, blocks, etc.) when cutting large, small or awkward workpieces.
- Never use a person as a substitute for a table extension or as additional support for a workpiece that is longer or wider than the basic saw table.
- When cutting irregularly shaped workpieces, plan your work so it will not pinch the blade. For example, a piece of molding must lay flat on the saw table. Workpieces must not twist, rock or slip while being cut.

When backing up the workpiece, the blade may bind in the kerf (cut). This is usually caused by sawdust clogging the

# OPERATION

kerf or when the blade comes out of the guides. If this happens:

- Wait until the saw has come to a full and complete stop.
- Place the switch in the **OFF** position then remove the switch key from the switch assembly. Store key in a safe place.
- Unplug the saw from the power source.
- Wedge the kerf open with a flat screwdriver or wooden wedge.
- Open front cover and turn the upper wheel by hand while backing up the workpiece.

## RELIEF CUTS

Relief cuts are made when an intricate curve (too small a radius for the blade) is to be cut. Cut through a scrap section of the workpiece to curve in pattern line then carefully back the blade out. Several relief cuts should be made for intricate curves before following the pattern line as sections are cutoff of curve “relieving” blade pressure.

## SCROLL CUTTING

For general type scroll cutting, follow the pattern lines by pushing and turning the workpiece at the same time. Do not try to turn the workpiece while engaged in the blade without pushing it – the workpiece could bind or twist the blade.

## REMOVING JAMMED MATERIAL

Never remove jammed cutoff pieces until the blade has come to a full and complete stop.

- Place the switch in the **OFF** position, remove the switch key from the switch assembly.
- Unplug the saw from the power source before removing jammed material.

## AVOIDING INJURY

- Make sure saw is level and does not rock. Saw should always be on a firm, level surface with plenty of room for handling and properly supporting the workpiece.
- Bolt saw to the support surface to prevent slipping, walking or sliding during operations like cutting long, heavy boards.
- Turn saw off, remove switch key, and unplug cord from the power source before moving the saw.
- Do not remove jammed cutoff pieces until blade has come to a full and complete stop.
- Choose the right size and style blade for the material and type of cut you plan to do.
- Make sure that the blade teeth point down toward the saw table, that the blade guides, thrust bearings, and blade tension are properly adjusted, that the blade guide knob is tight, and that no parts have excessive play.
- To avoid accidental blade contact, minimize blade breakage, and provide maximum blade support, always adjust the blade guide assembly to just clear the workpiece.
- Use only recommended accessories.

- With the exception of the workpiece and related support devices, clear everything off the saw table before turning the saw on.
- Properly support round materials such as dowel rods or tubing because they have a tendency to roll during a cut causing the blade to “bite”. To avoid this, always use a “V” block or clamp workpiece to a miter gauge
- Before removing loose pieces from the saw table, turn saw off and wait for all moving parts to stop.

## LOCKING THE SWITCH

See Figure 12.

- Wait until the saw has come to a full and complete stop.
- Place the switch in the **OFF** position, remove the switch key from the switch assembly. Store key in a safe place.

## BEFORE LEAVING THE SAW

See Figure 12.

- Wait until the saw has come to a full and complete stop.
- Place the switch in the **OFF** position, remove the switch key from the switch assembly. Store key in a safe place.
- Unplug the saw from the power source.
- Make workshop childproof.
- Lock the shop.

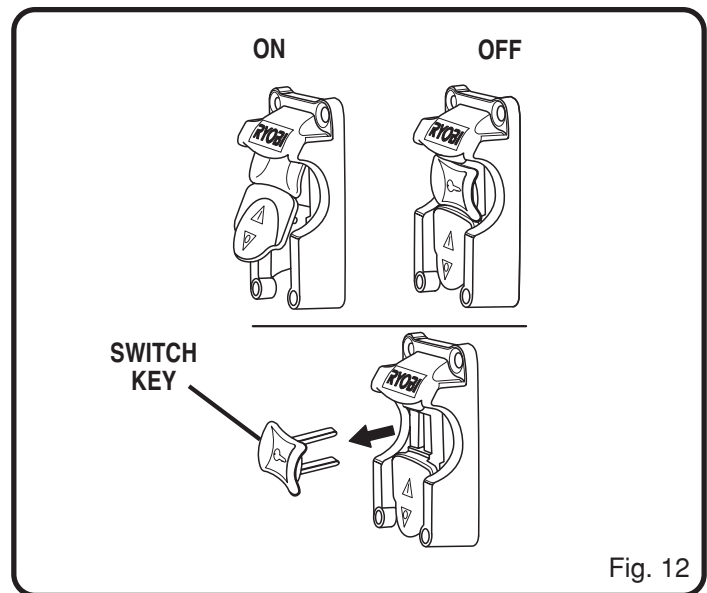

Fig. 12

# OPERATION

## **⚠ WARNING:**

Do not allow familiarity with your saw make you careless. Remember that a careless fraction of a second is sufficient to inflict severe injury.

## **TILTING THE TABLE**

See Figure 13.

- Loosen the table lock handle slightly.
- Turn the angle adjustment knob, tilting the saw table toward the front of the saw housing until it reaches the desired angle.
- Using the scale indicator, check angle markings.
- Retighten the table lock handle to hold saw table securely in place.

## **USING THE MITER GAUGE**

See Figures 13 and 14.

The miter gauge can be turned 60° to the right or left.

- Loose the lock knob on the miter gauge.
- With the miter gauge in the miter gauge slot, rotate the gauge until the desired angle is reached on the index scale.
- Retighten the lock knob.

**NOTE:** For convenience, store the miter gauge in the slot provide on the back of the band saw. See figure 13.

## **USING THE RIP FENCE**

See Figure 15.

From either side of the saw table, slide the rip fence onto the saw table. Check for a smooth, gliding action. Push the locking handle down to automatically align and secure the fence.

**Note:** Rip fence may be used on either side of the saw table.

## **⚠ WARNING:**

To reduce the risk of injury, always make sure the rip fence is parallel to the blade before beginning any operation.

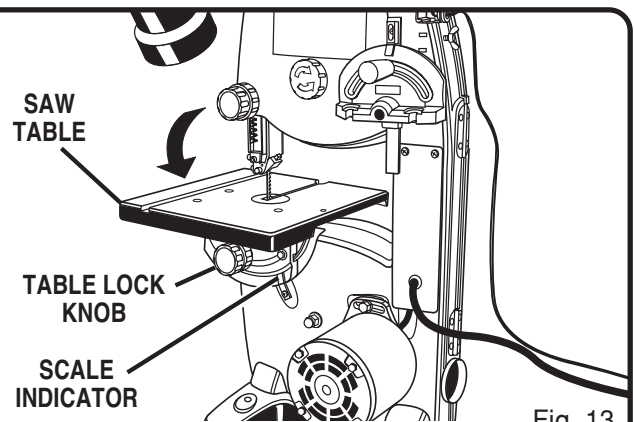

Fig. 13

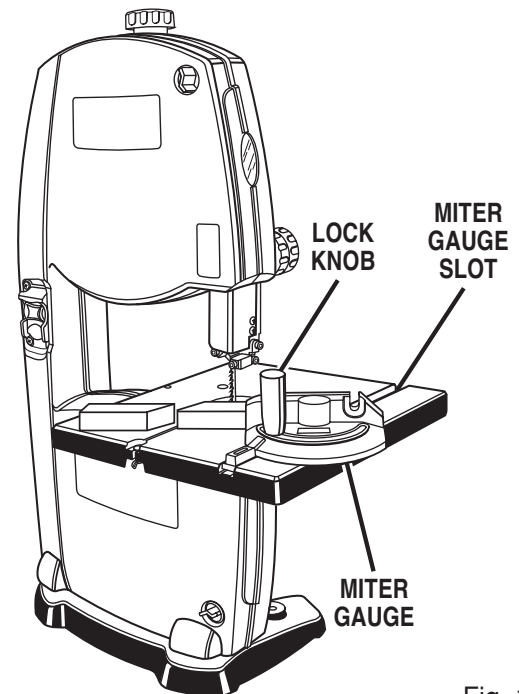

Fig. 14

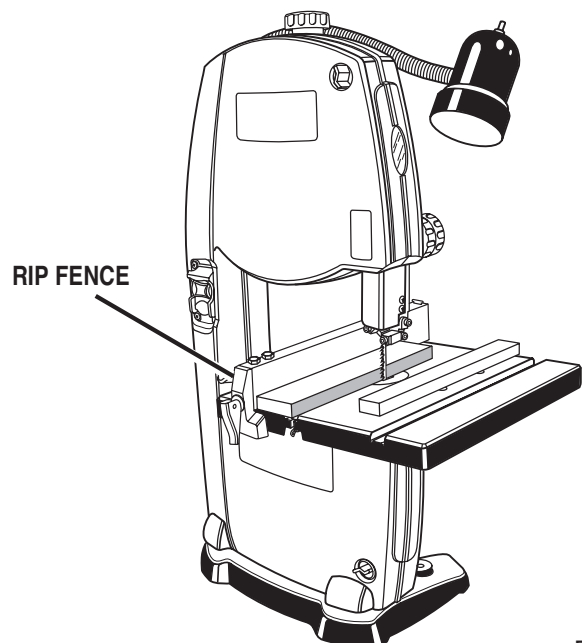

Fig. 15



# ADJUSTMENTS

## **⚠ WARNING:**

Failure to turn the saw off, remove the switch key, and unplug the saw could result in accidental starting causing possible serious personal injury.

## INSTALLING AND ADJUSTING THE BLADE

See Figures 16 and 17.

## **⚠ WARNING:**

Failure to turn the saw off, remove the switch key, and unplug the saw could result in accidental starting causing possible serious personal injury.

## **⚠ WARNING:**

Always wear safety goggles or safety glasses with side shields to protect your eyes while uncoiling band saw blades. Failure to heed this warning could result in a serious eye injury.

- Loosen and remove the wing nut and table aligning bolt from the saw table. See Figure 16.
- Open the front cover by releasing the upper and lower latches.
- Loosen the two set screws that hold the blade guard in place using the 4 mm hex key provided then remove the blade guard. See Figure 16.
- Turn the lock knob counterclockwise to unlock the blade guide assembly. Turning the blade guide knob (clockwise raises the blade guide assembly; counterclockwise lowers it), position the blade guide assembly about halfway between the saw table and saw housing. Retighten the lock knob.
- Release blade tension by pushing the RapidSet™ blade tension lever to the left. See Figure 17.
- Carefully remove the old blade.
- Wearing gloves, carefully uncoil the blade at arms length. If the new blade was oiled to prevent rusting, it may need to be wiped to keep the oil from your workpiece. Carefully wipe in the same direction the teeth are pointing so the rag does not catch on the teeth of the saw blade.

**NOTE:** The blade may need to be turned inside out if the teeth are pointing in the wrong direction. Hold the blade with both hands and rotate it inward.

- With the teeth of the blade toward the front of the saw and facing downward, place the blade through the lower blade guides and around the lower wheel. Pull down on the upper wheel to place the saw blade on the wheel.

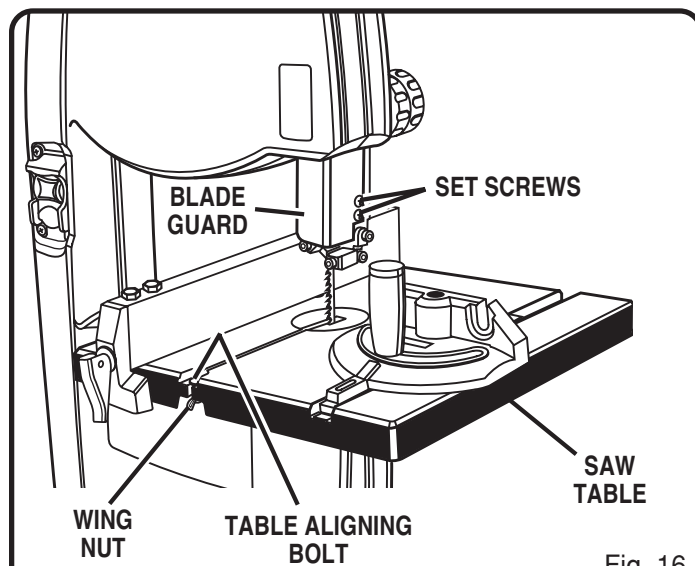

Fig. 16

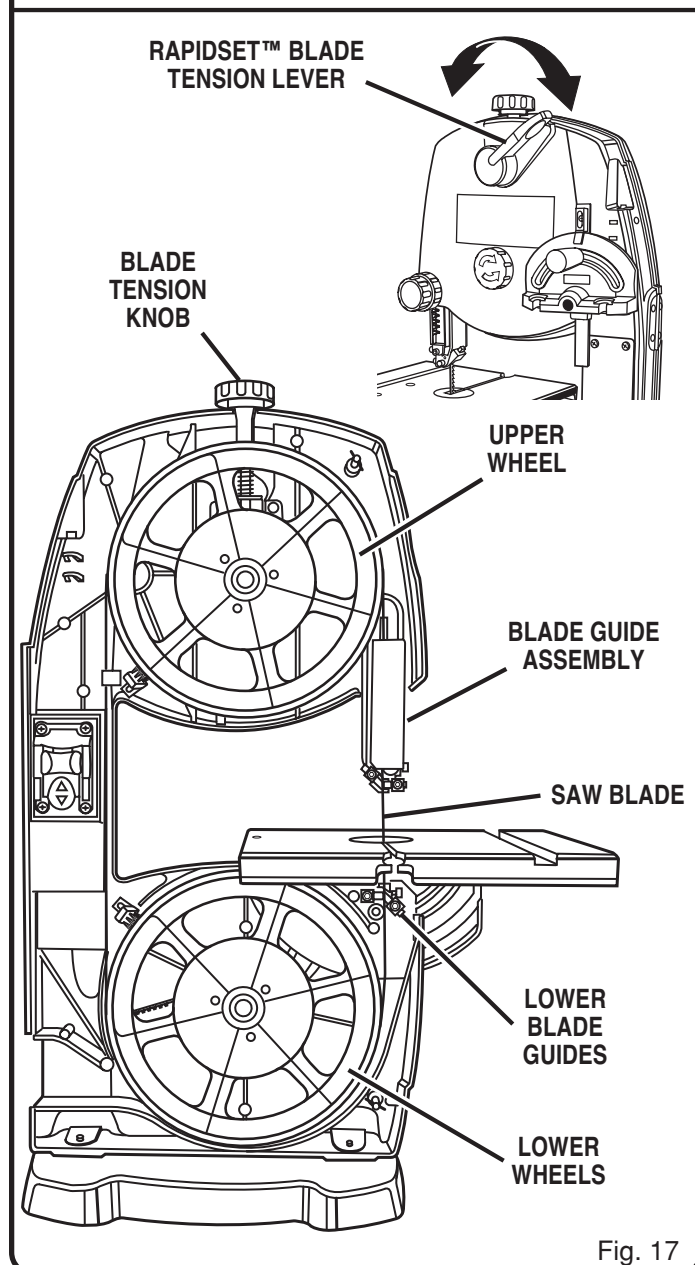

Fig. 17

# ADJUSTMENTS

- Slowly turn the upper wheel to the right or clockwise by hand to center the blade on the rubber tires.
- Adjust the blade tension; check or adjust the blade tracking and re-engage the RapidSet™ blade tension lever.
- Adjust both upper and lower blade guides and thrust bearings.
- Reattach the aligning bolt, washer, and wing nut. Tighten securely.
- Reattach the blade guard.
- Close front cover.

## ADJUSTING BLADE GUIDE ASSEMBLY

See Figures 18 and 19.

### **⚠ WARNING:**

The blade guides have been preset at the factory. These settings are functional for some applications. We recommend that you check and adjust blade guide settings before first use of your saw. Refer to “Adjusting thrust bearings, blade guide support, and blade guides” procedures explained in the adjustments section of this operator’s manual.

To prevent the blade from twisting or breaking, the blade guide assembly should always be set approximately 1/8 in. (3 mm) above the workpiece.

- Turn the lock knob counterclockwise to unlock the blade guide assembly.
- As a guide, use a scrap piece of the same wood you are about to cut to set the height of the blade guide assembly. Adjust the blade guide assembly by turning the blade guide knob.
- Lock blade guide assembly in place by turning the lock knob clockwise.
- Always lock the blade guide assembly in place before turning on the band saw.

### **⚠ WARNING:**

To avoid personal injury, maintain proper adjustment of blade tension, blade guides, and thrust bearings.

- To check tension, raise the blade guide assembly all the way up to expose the blade.
- Push the blade to the side with moderate force; the blade should flex approximately 1/8 in. (3 mm).

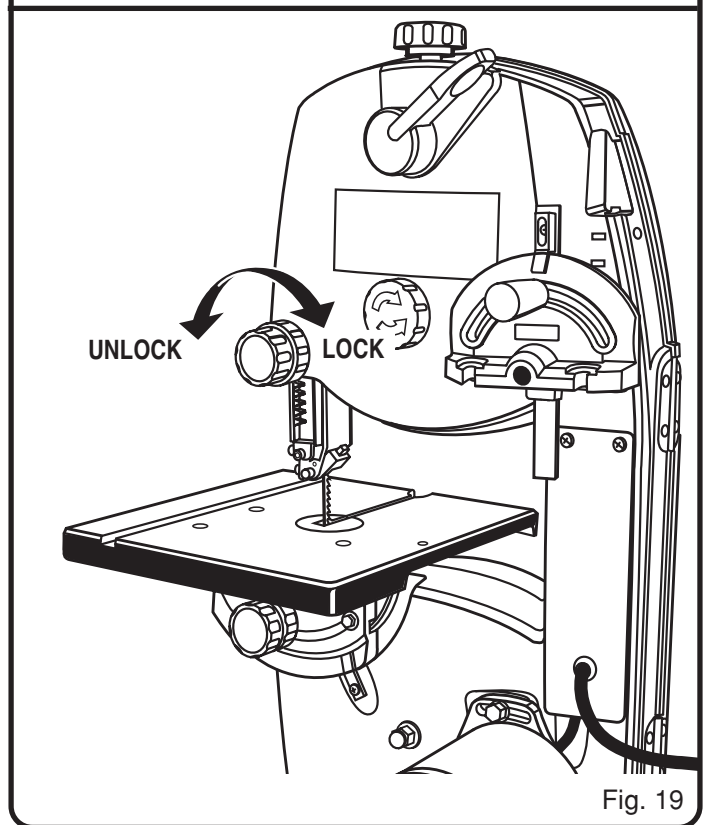
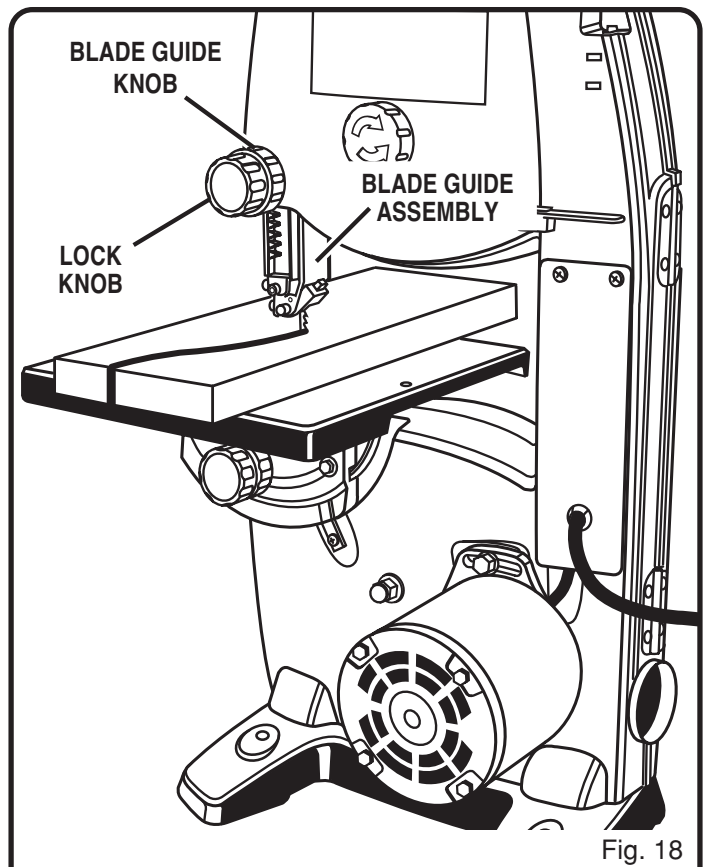

# ADJUSTMENTS

## ADJUSTING THRUST BEARINGS, BLADE GUIDE SUPPORT, AND BLADE GUIDES

See Figures 20 - 22.

The upper and lower blade guides and thrust bearings support the band saw blade during cutting operations. The adjustment of the guides and bearings should be checked whenever a different blade is installed.

### **WARNING:**

Failure to turn the saw off, remove the switch key, and unplug the saw could result in accidental starting causing possible serious personal injury.

### To Adjust Thrust Bearings:

The thrust bearings support the back edge of the blade during cutting. The blade should not contact the thrust bearings when you stop cutting. It is important that both upper and lower thrust bearings be adjusted equally.

**NOTE:** The thrust bearing screw is the upper cap screw located on the right side of the blade guide assembly. It is the lower cap screw on the right side of the saw housing below the saw table for the lower bearing. See Figures 20 and 21.

- Remove the blade guard by loosening the two phillips screws.
- Turn the lock knob counterclockwise to unlock the blade guide assembly. Turning the blade guide knob clockwise, raise the blade guide assembly as far as it will go. Turn the lock knob clockwise to retighten.
- Adjust the thrust bearings first. Using the 4 mm hex key, loosen the thrust bearing screw.
- Move the thrust bearing to within 1/64 in. (0.4 mm) of the blade. Tighten the thrust bearing screw securely. Repeat this procedure on the lower thrust bearing located below the saw table.
- Replace the blade guard if no additional adjustments are to be made.

### To Adjust Blade Guide Support:

- Remove the blade guard by loosening the two phillips screws.
- Adjust the position of the blade guide assembly. Loosen the bottom screw on the right side of the blade guide assembly using the 4 mm hex key.
- Slide the upper blade guide support on the shaft until the front edge of the blade guides are about 1/64 in. (0.4 mm) behind the gullet of the blade. Tighten the screw securely. Repeat this procedure for the lower blade guide support.
- Replace the blade guard if no additional adjustments are to be made.

**NOTE:** The lower blade guide support screw is the top screw located on the right of the saw housing under the table. See Figure 21.

### **WARNING:**

Never operate saw without blade guard secured in place. To do so could result in possible serious personal injury.

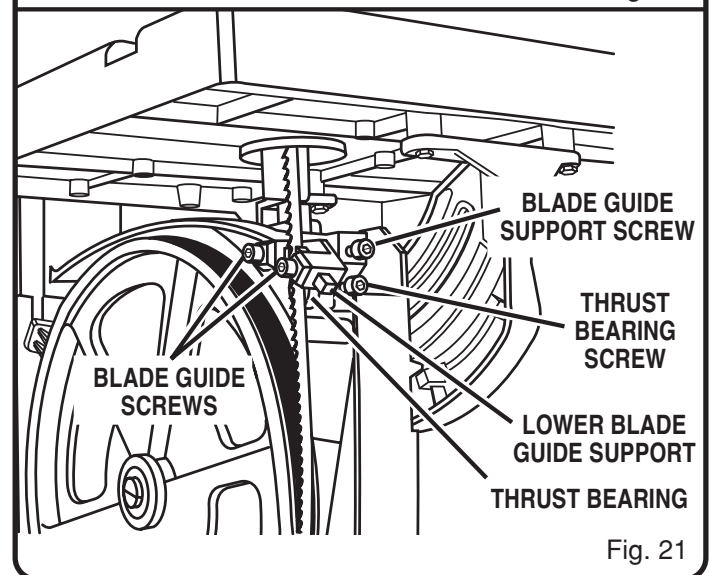
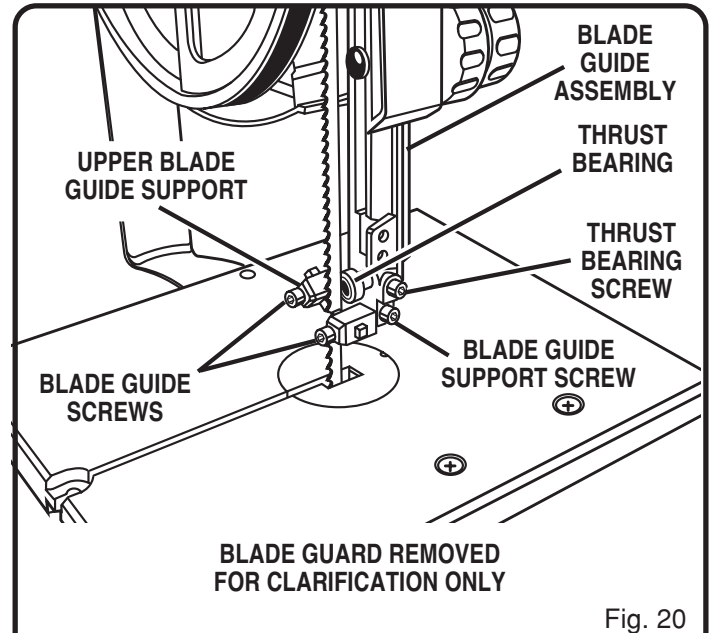

# ADJUSTMENTS

## To Adjust Blade Guides:

The blade guides help keep the blade from twisting and binding. The blade will be ruined if the blade teeth hit the blade guides while using the band saw. The set of teeth and the sharpened edge of teeth will be damaged by hitting the blade guides. Proper adjustment of the upper and lower blade guides will prevent this from happening.

- Remove the blade guard by loosening the two phillips screws.
- Loosen the two blade guide support screws that lock the upper blade guides. Slide the two guides to within 1/32 in. (0.8 mm) of the blade. Do not pinch the blade. Make sure one guide is not further away from the blade than the other. Retighten the two blade guide support screws securely.
- Replace the blade guard if no additional adjustments are to be made.
- Repeat this procedure on the lower blade guides located under the saw table. See Figure 21.

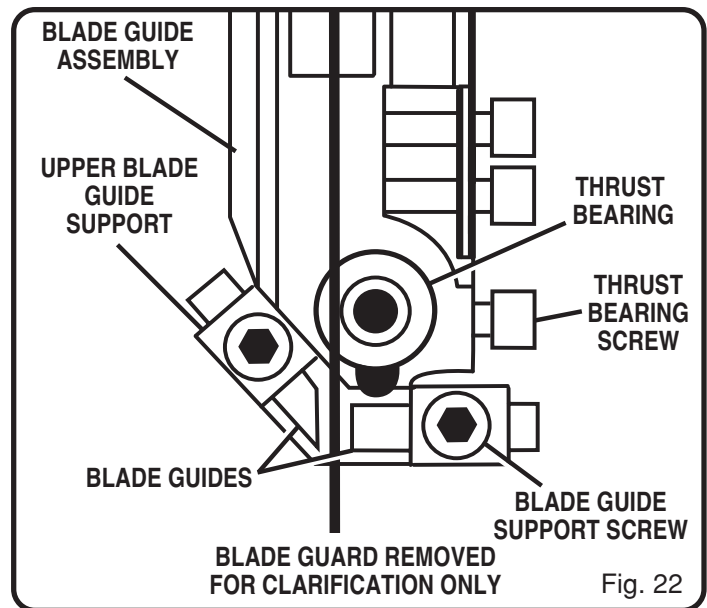

# MAINTENANCE

## ⚠ WARNING:

To ensure safety and reliability, all repairs should be performed by an authorized service center.

## GENERAL MAINTENANCE

Avoid using solvents when cleaning parts. Most plastics are susceptible to damage from various types of commercial solvents and may be damaged by their use. Use clean cloths to remove dirt, carbon dust, etc.

## ⚠ WARNING:

Do not, at any time, let brake fluids, gasoline, petroleum-based products, penetrating oils, etc., come in contact with plastic parts. They contain chemicals that can damage, weaken or destroy plastic.

- Keep your band saw clean.
- Remove sawdust from the inside frequently.
- Do not allow pitch to accumulate on the saw table, blade guides, or thrust bearings. Clean them with gum and pitch remover.
- Apply a thin coat of automobile type wax to the saw table's top so the wood slides easily while cutting.

## ⚠ WARNING:

To prevent accidental starting that could cause possible serious personal injury, turn off the saw, remove the switch key, and unplug the saw before working on the band saw.

## MOTOR/ELECTRICAL

- Frequently vacuum or blow out sawdust from the motor.

## ⚠ WARNING:

If the power cord is worn, cut or damaged in any way, have it replaced immediately by a qualified service technician. Failure to do so could result in serious personal injury.

## ⚠ WARNING:

To avoid fire or electrocution, reassemble electric parts with only identical replacement parts. Reassemble exactly as originally assembled.

## TIRES

### Cleaning tires:

- Pitch and sawdust accumulates on tires and needs to be removed with a fine wire brush or a piece of wood. **Do not** use a sharp knife or any kind of solvent.

### Replacing tires:

- Open front cover and remove saw blade. See section on **Installing and Adjusting the Blade**, page 17.
- Pry the worn tire away from the wheel carefully.
- Stretch the new tire around the wheel.
- Replace the saw blade and close the front cover.

## BLADE GUIDES

See Figure 22.

- Blade guides may become rounded and worn during use. Remove the blade guides and file or grind flat.
- Replace blade guides when filing or grinding has worn them down and they can no longer be properly secured in place.

# MAINTENANCE

## LUBRICATION

All the bearings in this tool are lubricated with a sufficient amount of high grade lubricant for the life of the unit under normal operating conditions. Therefore no further lubrication is required.

## BRUSHES

See Figure 23.

### **⚠ WARNING:**

To prevent accidental starting that could cause possible serious personal injury, turn off the saw, remove the switch key, and unplug the saw before working on the band saw.

There is a brush located inside the saw housing, next to the lower wheel. It helps protect the tire and wheel by brushing off saw dust. As the brush becomes worn, it will need to be adjusted or replaced.

- Remove the screw then pull the brush off.
- Place the new brush in the groove.
- Retighten using the screw.

## DRIVE BELT

See Figures 24 and 25.

### **⚠ WARNING:**

To prevent accidental starting that could cause possible serious personal injury, turn off the saw, remove the switch key, and unplug the saw before working on the band saw.

Due to wear or breakage, the drive belt may need to be replaced. The drive belt is located behind the lower wheel of the band saw.

- Remove the saw blade and set it aside. See section on **Installing and Adjusting the Blade**, page 17.

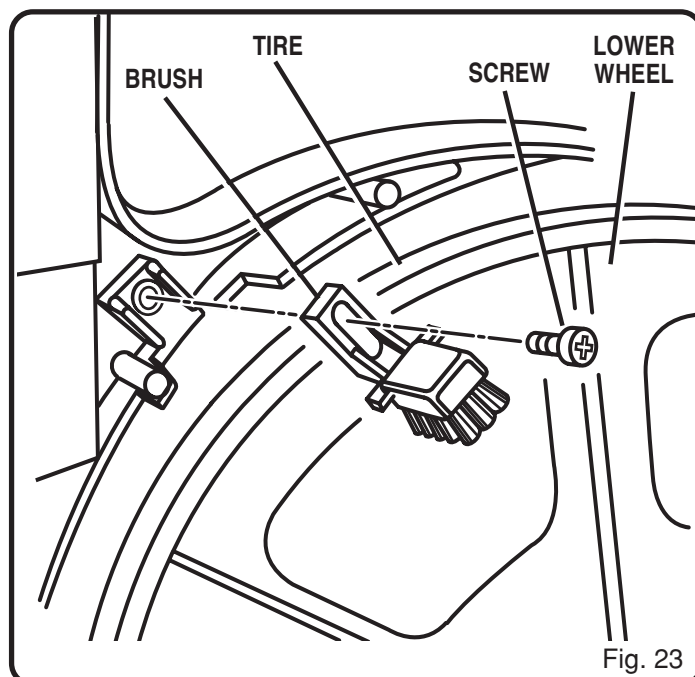

- Remove the nut and washer from the middle of the saw housing. See Figure 24.
- Pull the lower wheel away from the saw housing.
- Remove the worn drive belt.
- Place new drive belt on the pulley. As you slide the pulley shaft back into the hole in the saw housing, place the drive belt over the motor pulley.
- Replace the nut and washer on the pulley shaft and retighten.
- Replace saw blade.
- Check thrust bearings and blade guides.

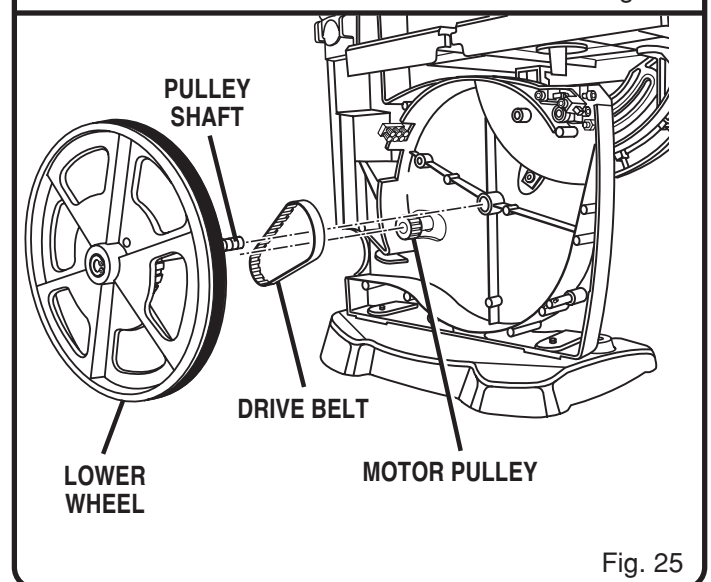
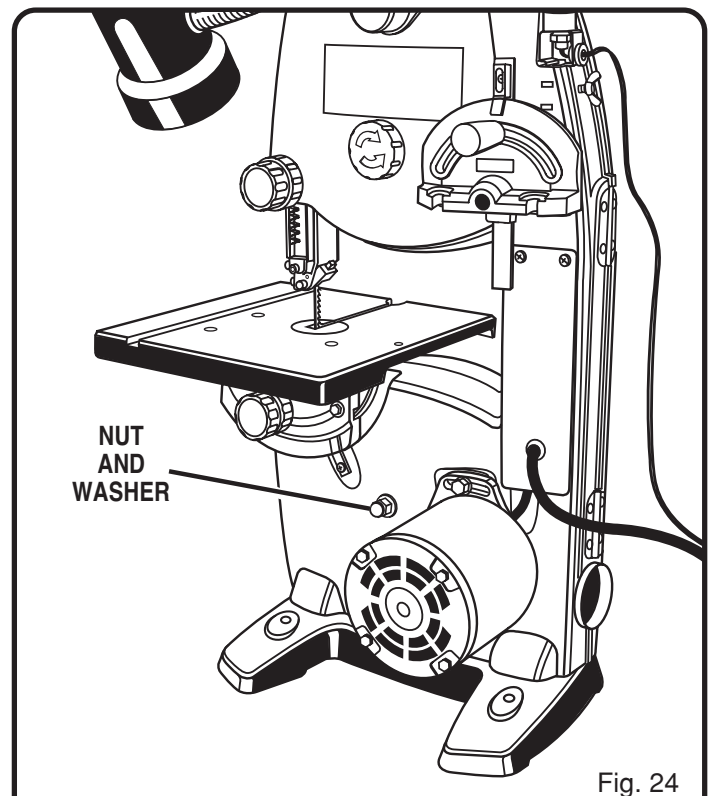

# TROUBLESHOOTING

## **WARNING:**

To prevent accidental starting that could cause possible serious personal injury, turn off the saw, remove the switch key, and unplug the saw from the power source before working on the band saw.

<b>PROBLEM</b>	<b>CAUSE</b>	<b>SOLUTION</b>
Motor will not run.	<ol style="list-style-type: none"> <li>1. Problem with On-Off switch or power cord.</li> <li>2. Motor defective.</li> </ol>	<ol style="list-style-type: none"> <li>1. Have worn parts replaced before using band saw again.</li> <li>2. Do not attempt any repair. Have tool repaired by a qualified service technician.</li> </ol>
Blade does not run in the approximate center of the upper wheel.	<ol style="list-style-type: none"> <li>1. Not tracking properly.</li> </ol>	<ol style="list-style-type: none"> <li>1. Adjust tracking, See <i>Adjustments</i> section, <b>Tracking the Blade</b>.</li> </ol>
Band Saw slows down when cutting.	<ol style="list-style-type: none"> <li>1. Cutting too small a radius.</li> <li>2. Dull blade.</li> </ol>	<ol style="list-style-type: none"> <li>1. Stop feeding and back up the material slightly until the band saw speeds up.</li> <li>2. Replace blade.</li> </ol>
Blade breaking.	<ol style="list-style-type: none"> <li>1. Too much blade tension.</li> <li>2. Kink in blade caused by cutting too small radius or turning the material too fast when cutting.</li> <li>3. Thrust bearings scarred or not rotating.</li> </ol>	<ol style="list-style-type: none"> <li>1. Adjust tension. See <i>Adjustments</i> section, <b>Adjusting Blade Tension</b>.</li> <li>2. Use correct cutting technique. See section, <i>Operation</i>.</li> <li>3. Replace the thrust bearings.</li> </ol>
Saw is noisy when running.	<ol style="list-style-type: none"> <li>1. Too much blade tension.</li> <li>2. Blade guides and bearings are in contact with the blade.</li> </ol>	<ol style="list-style-type: none"> <li>1. Adjust tension. See <i>Adjustments</i> section, <b>Adjusting Blade Tension</b>.</li> <li>2. Adjust upper and lower blade guides and bearings. See <i>Adjustments</i> sections, <b>Adjusting Thrust Bearings, Blade Guide Support, and Blade Guides</b>.</li> </ol>
Blade will not cut straight.	<ol style="list-style-type: none"> <li>1. Blade guides and bearings not properly adjusted.</li> <li>2. Worn or defective blade.</li> </ol>	<ol style="list-style-type: none"> <li>1. Adjust upper and lower blade guides and bearings. See <i>Adjustments</i> sections, <b>Adjusting Thrust Bearings, Blade Guide Support, and Blade Guides</b>.</li> <li>2. Replace blade.</li> </ol>
Blade guides will not stay in position.	<ol style="list-style-type: none"> <li>1. Blade guide screws have loosened.</li> </ol>	<ol style="list-style-type: none"> <li>1. Tighten blade guide screws securely.</li> </ol>



