

RYOBI 10 in. (254 mm)

BAND SAW

MODEL NO. BS1001SV

REPAIR SHEET

FIGURE A

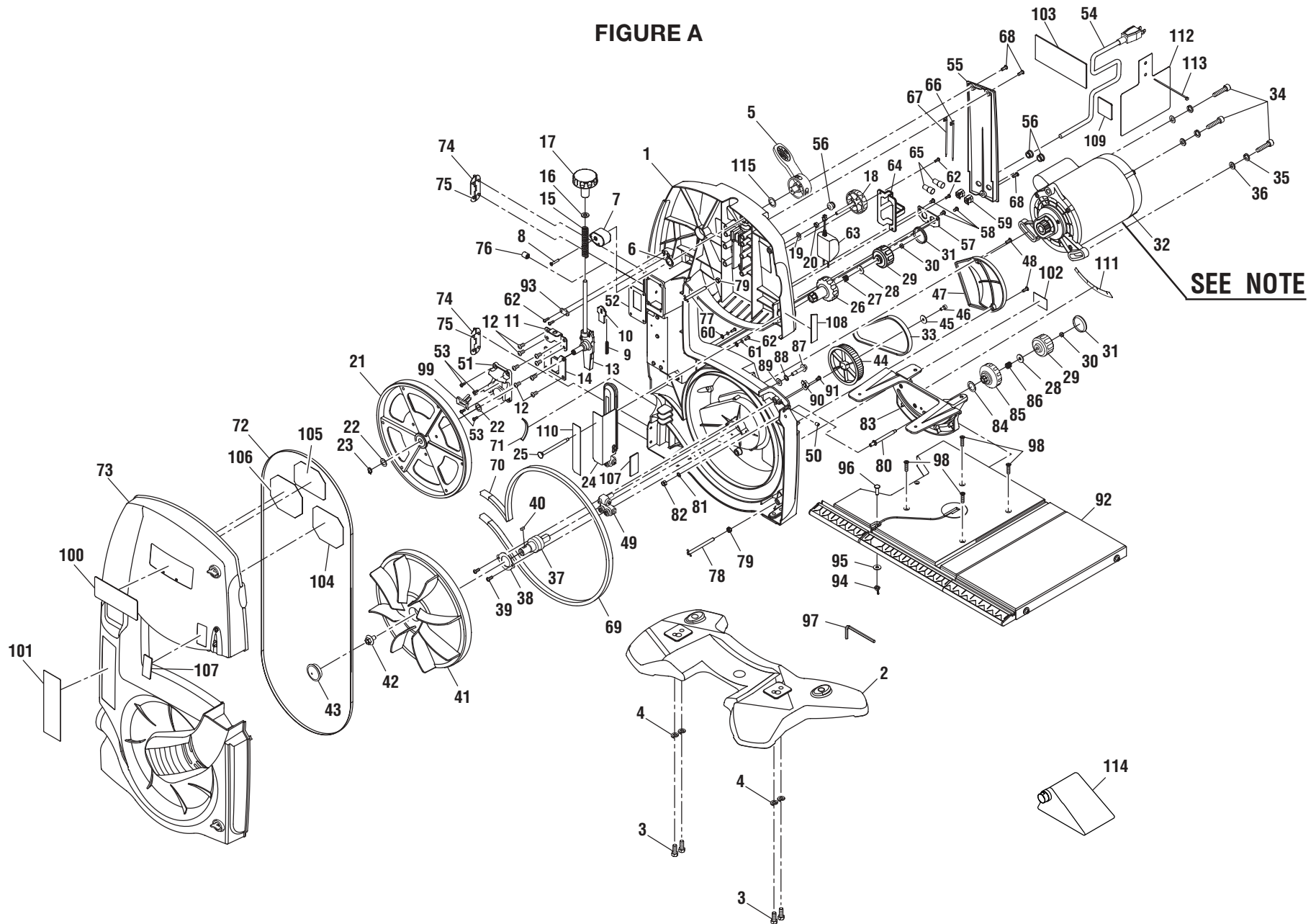

NOTE: The assembly shown represents an important part of the double insulated system. To avoid the possibility of alteration or damage to the system, service should be performed by your nearest Ryobi Authorized Service Center. For the service center nearest you call 1-800-525-2579.

RYOBI 10 in. (254 mm) BAND SAW – MODEL NUMBER BS1001SV

The model number will be found on a plate attached to the motor housing. Always mention the model number in all correspondence regarding your **BAND SAW** or when ordering repair parts.

PARTS LIST - FIGURE A

Key No.	Part Number	Description	Qty.	Key No.	Part Number	Description	Qty.
1	225308-000	FRAME	1	31	303695-000	LOCK KNOB END PLATE	2
2	240065-000	BASE	1	32	990038-000	MOTOR ASSEMBLY	1
3	020314-015	* HEX SCREW (M8 X 20 mm)	4	33	041007-000	GEAR BELT	1
4	021204-001	WASHER	4	34	6616922	* SCREW (M8 x 35 mm)	3
5	303649-000	WHEEL LOCK KNOB	1	35	021204-001	SWASHER	3
6	021118-002	WASHER	1	36	021120-017	WASHER	3
7	060124-000	DRIVE CAM	1	37	901073-000	LOWER WHEEL SHAFT ASSEMBLY	1
8	020804-012	* FLAT SCREW (M4 X 22 mm)	1	38	270748-000	BEARING COVER	1
9	029185-001	COMPRESSION SPRING	1	39	020106-035	PAN SCREW (CROSS)	2
10	270747-000	SLIDE	1	40	027201-002	KEY	1
11	270677-000	SLIDE PLATE	1	41	901074-000	LOWER WHEEL ASSEMBLY	1
12	020102-025	* PAN SCREW (M6 X 12 mm)	8	42	020300-011	* SCREW (M8 X 14 mm)	1
13	900982-000	UPPER WHEEL BASE ASSEMBLY	1	43	330095-000	FAN END CAP	1
14	270218-000	LOCK PLATE	1	44	303735-000	DRIVE GEAR	1
15	029194-001	COMPRESSION SPRING	1	45	021125-009	WASHER	1
16	021120-003	WASHER	1	46	020601-007	* SCREW (M5 x 12 mm)	1
17	303650-000	WHEEL ADJUSTMENT KNOB	1	47	303736-000	DRIVE GEAR COVER	1
18	303651-001	ADJUSTMENT KNOB	1	48	020103-002	* PAN SCREW (M4 x 12 mm)	2
19	021101-008	WASHER	1	49	901075-000	SUPPORT GUIDE ASSEMBLY	1
20	022111-002	HEX NUT	1	50	020504-007	* SCREW (M6 X 8 mm)	1
21	901071-000	UPPER WHEEL ASSEMBLY	1	51	984406001	SWITCH (KEDU HY 18-13)	1
22	021504-009	INSULATION WASHER	2	52	270689-000	SWITCH PLATE	1
23	023102-001	"C" RING	1	53	020103-033	* PAN SCREW (M4 x 10 mm)	4
24	901072-000	BLADE GUIDE ASSEMBLY	1	54	080406-003	POWER CORD (18 AWG X 1945L)	1
25	028989-001	CARRIAGE BOLT	1	55	303737-000	SWITCH COVER	1
26	303734-000	DRIVE KNOB	1	56	330082-000	GROMMET	3
27	029192-001	COMPRESSION SPRING	1	57	270749-000	CORD LOCK PLATE	1
28	021101-013	WASHER	2	58	020106-035	* PAN SCREW (CROSS) (M5 X 8 mm)	3
29	303653-000	LOCK KNOB	2	59	913001-000	STRAIN RELIEF	2
30	022301-001	NYLON NUT	2				

WARNING: Improper repair of a double insulated tool can result in damage to the double insulation system possibly causing electrical shock or electrocution. Any repairs requiring disassembly of your tool requires safety testing and should only be performed by a Ryobi Authorized Service Center. For the service center nearest you call 1-800-525-2579.

* Standard Hardware Item – May Be Purchased Locally

RYOBI 10 in. (254 mm) BAND SAW – MODEL NUMBER BS1001SV

The model number will be found on a plate attached to the motor housing. Always mention the model number in all correspondence regarding your **BAND SAW** or when ordering repair parts.

PARTS LIST - FIGURE A CONTINUED

Key No.	Part Number	Description	Qty.	Key No.	Part Number	Description	Qty.
60	021306-002	WASHER	2	89	021103-010	WASHER	1
61	021201-003	SWASHER	2	90	303738-000	BEVEL INDICATOR	1
62	020103-031	* PAN SCREW (M4 x 8 mm)	6	91	020716-000	* PAN SCREW ASSEMBLY (M5 X 8 mm)	1
63	372013-000	TRANSFORMER	1	92	901070-000	TABLE ASSEMBLY	1
64	303762-000	TRANSFORMER LOCK	1	93	303006-000	CORD CLAMP	1
65	364001-001	TERMINAL	2	94	022603-000	* WING NUT (M6)	1
66	080506-001	SWITCH WIRE (18 AWG X 100L, BLACK) ...	1	95	021101-011	WASHER	1
67	080506-000	SWITCH WIRE (18 AWG X 100L, WHITE)	1	96	028967-000	* BOLT (M6 X 19 mm)	1
68	020106-036	* PAN SCREW (M5 x 12 mm)	3	97	040005-003	WRENCH (3 mm)	1
69	330083-000	GASKET (970 mm)	1	98	020808-007	* SCREW (M6 X 21 mm)	4
70	330083-001	GASKET (80 mm)	1	99	984406003	SWITCH KEY	1
71	914024-000	SPONGE	1	100	863209-000	3D LOGO	1
72	351009-002	BLADE (1/4 in.)	1	101	863210-003	WARNING LABEL	1
	351009-003	BLADE (3/8 in.)	1	102	871059-000	RATING LABEL	1
73	901076-000	COVER ASSEMBLY	1	103	863209-002	BLADE TRACKING AND ADJUSTING LABEL	1
74	270680-000	HINGE	2	104	863210-004	BLADE CHART (FRENCH)	1
75	024201-000	RIVET	8	105	863210-005	BLADE CHART (ENGLISH)	1
76	330096-000	LOCK WIRE ROD	1	106	863210-006	BLADE CHART (SPANISH)	1
77	290295-000	UPPER LOCK SHAFT	1	107	863209-003	KEEP HANDS AWAY WARNING LABEL	2
78	290296-000	LOWER LOCK SHAFT	1	108	863209-004	LABEL FOR WINDOW	1
79	022111-007	* HEX NUT (M6)	2	109	863209-005	TRACKING LABEL	1
80	028977-000	SCREW	1	110	870039-000	CUTTING DEPTH SCALE	1
81	021200-001	WASHER	1	111	870037-001	BEVEL SCALE	1
82	022306-000	NYLON NUT	1	112	916141-003	POWER SUPPLY CORD WARNING LABEL .	1
83	901149-000	TABLE SUPPORT BRACKET ASSEMBLY ...	1	113	915008-000	NYLON TIE	1
84	021118-001	WASHER	1	114	901119-000	DUST BAG ASSEMBLY	1
85	303660-000	MICRO-ADJUSTING GEAR	1	115	021419001	WAVY WASHER	1
86	029138-000	COMPRESSION SPRING	1		983000-269	OPERATOR'S MANUAL	
87	028976-000	SCREW	1		983000-269R	REPAIR SHEET (REV:00)	
88	021403-007	WAVE WASHER	1		11-09-04		

WARNING: Improper repair of a double insulated tool can result in damage to the double insulation system possibly causing electrical shock or electrocution. Any repairs requiring disassembly of your tool requires safety testing and should only be performed by a Ryobi Authorized Service Center. For the service center nearest you call 1-800-525-2579.

* Standard Hardware Item – May Be Purchased Locally

FIGURE B

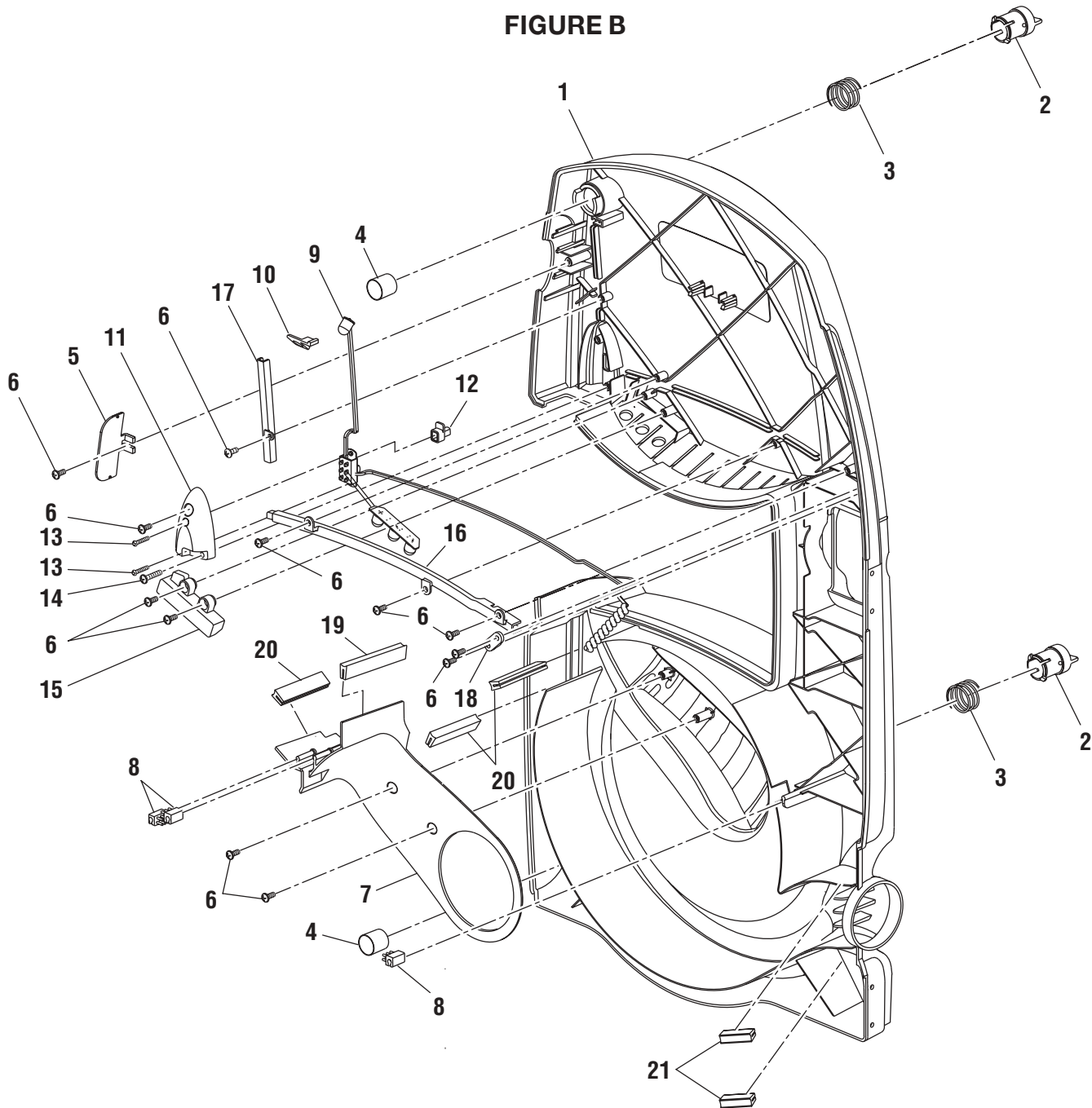

RYOBI 10 in. (254 mm) BAND SAW – MODEL NUMBER BS1001SV

The model number will be found on a plate attached to the motor housing. Always mention the model number in all correspondence regarding your **BAND SAW** or when ordering repair parts.

PARTS LIST - FIGURE B

Key No.	Part Number	Description	Qty.
1	303739-000	COVER	1
2	303656-000	DOOR LOCK KNOB	2
3	029187-001	COMPRESSION SPRING	2
4	303763-000	SUPPORT COVER	2
5	303740-000	TRACKING WINDOW	1
6	020132-001	* SELF-TAPPING SCREW (M4 X 10 mm)	1
7	303741-000	STRIPPER	1
8	303742-000	BRUSH	3
9	901120-000	LED LAMP	1
10	303743-000	LED FIXED SUPPORT	1
11	303744-000	SWTICH PROTECT COVER	1
12	303745-000	PUSHBUTTON	1
13	020109-007	* SCREW (M3 X 0.5 mm)	2
14	020200-001	* SELF-TAPPING SCREW (M4 X 20 mm)	1
15	303746-000	LED BOX	1
16	303747-000	WIRE PROTECT PLATE A	1
17	303748-000	WIRE PROTECT PLATE B	1
18	303006-000	CORD CLAMP	1
19	330083-002	GASKET (73 mm)	1
20	330083-003	GASKET (53 mm)	3
21	330083-004	GASKET (28 mm)	2

WARNING: Improper repair of a double insulated tool can result in damage to the double insulation system possibly causing electrical shock or electrocution. Any repairs requiring disassembly of your tool requires safety testing and should only be performed by a Ryobi Authorized Service Center. For the service center nearest you call 1-800-525-2579.

* Standard Hardware Item – May Be Purchased Locally

FIGURE C

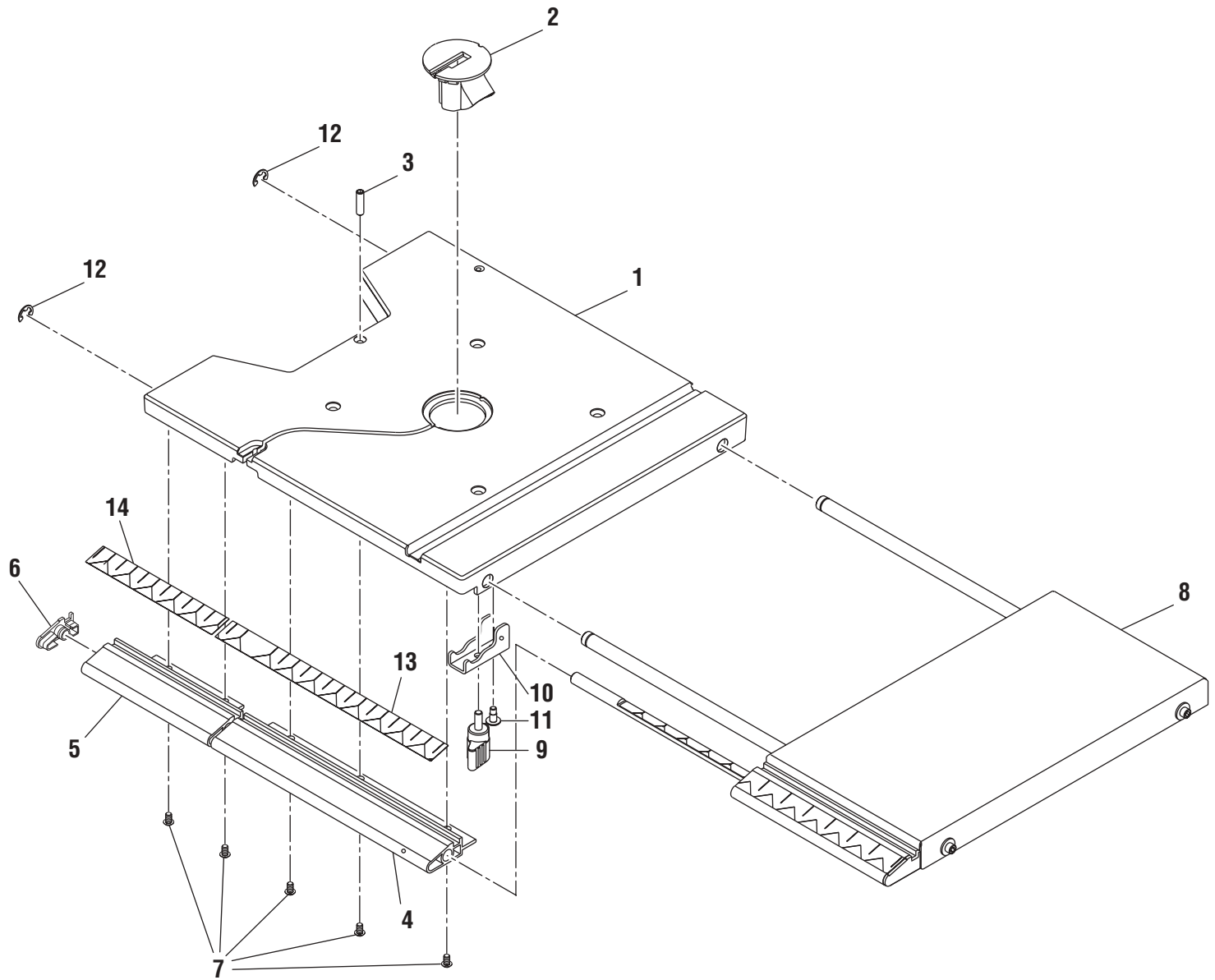

RYOBI 10 in. (254 mm) BAND SAW – MODEL NUMBER BS1001SV

The model number will be found on a plate attached to the motor housing. Always mention the model number in all correspondence regarding your **BAND SAW** or when ordering repair parts.

PARTS LIST - FIGURE C

Key No.	Part Number	Description	Qty.
1	225307-000	TABLE	1
2	303729-000	TABLE INSERT	1
3	020504-023	* SCREW SET (M6 X 22 mm)	1
4	203041-000	RIGHT RAIL	1
5	203041-001	LEFT RAIL	1
6	303730-000	LEFT CAP RAIL	1
7	020716-007	* SCREW (M5 X 10 mm)	5
8	901069-000	TABLE EXTENSION ASSEMBLY	1
9	303764-000	KNOB	1
10	270785-000	CLAMP BRACKET	1
11	030000-007	SPECIAL SCREW	1
12	023204-001	E-RING (E8)	2
13	870039-001	RIGHT SCALE	1
14	870039-004	LEFT SCALE	1

WARNING: Improper repair of a double insulated tool can result in damage to the double insulation system possibly causing electrical shock or electrocution. Any repairs requiring disassembly of your tool requires safety testing and should only be performed by a Ryobi Authorized Service Center. For the service center nearest you call 1-800-525-2579.

* Standard Hardware Item – May Be Purchased Locally

FIGURE D

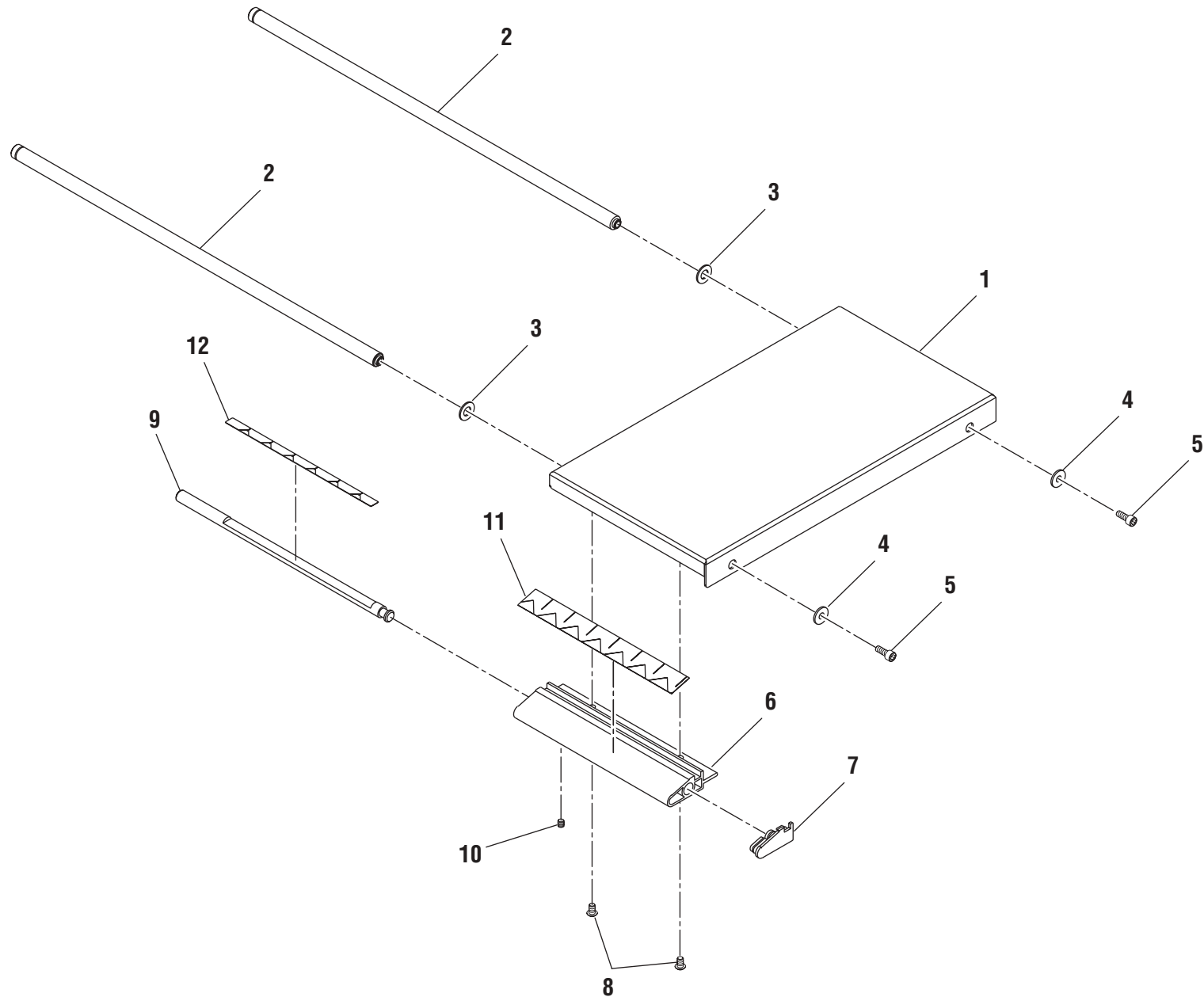

RYOBI 10 in. (254 mm) BAND SAW – MODEL NUMBER BS1001SV

The model number will be found on a plate attached to the motor housing. Always mention the model number in all correspondence regarding your **BAND SAW** or when ordering repair parts.

PARTS LIST - FIGURE D

Key No.	Part Number	Description	Qty.
1	270746-000	EXTENSION TABLE	1
2	290292-000	SLIDE BAR	2
3	021120-003	WASHER	2
4	021125-011	WASHER	2
5	020601-007	* SCREW (M5 X 12 mm)	2
6	203040-000	EXTENSION BAR	1
7	303731-000	RIGHT END PLATE	1
8	020716-007	* SCREW SET (M5 X 10 mm)	2
9	290294-000	EXTENSION RAIL ROD	1
10	020502-003	* SELF-TAPPING SCREW (M5 X 5 mm)	1
11	870039-002	EXTENSION BAR SCALE	1
12	870039-003	RAIL ROD SCALE	1
	901069-000	TABLE ASSEMBLY	1

WARNING: Improper repair of a double insulated tool can result in damage to the double insulation system possibly causing electrical shock or electrocution. Any repairs requiring disassembly of your tool requires safety testing and should only be performed by a Ryobi Authorized Service Center. For the service center nearest you call 1-800-525-2579.

* Standard Hardware Item – May Be Purchased Locally

FIGURE E

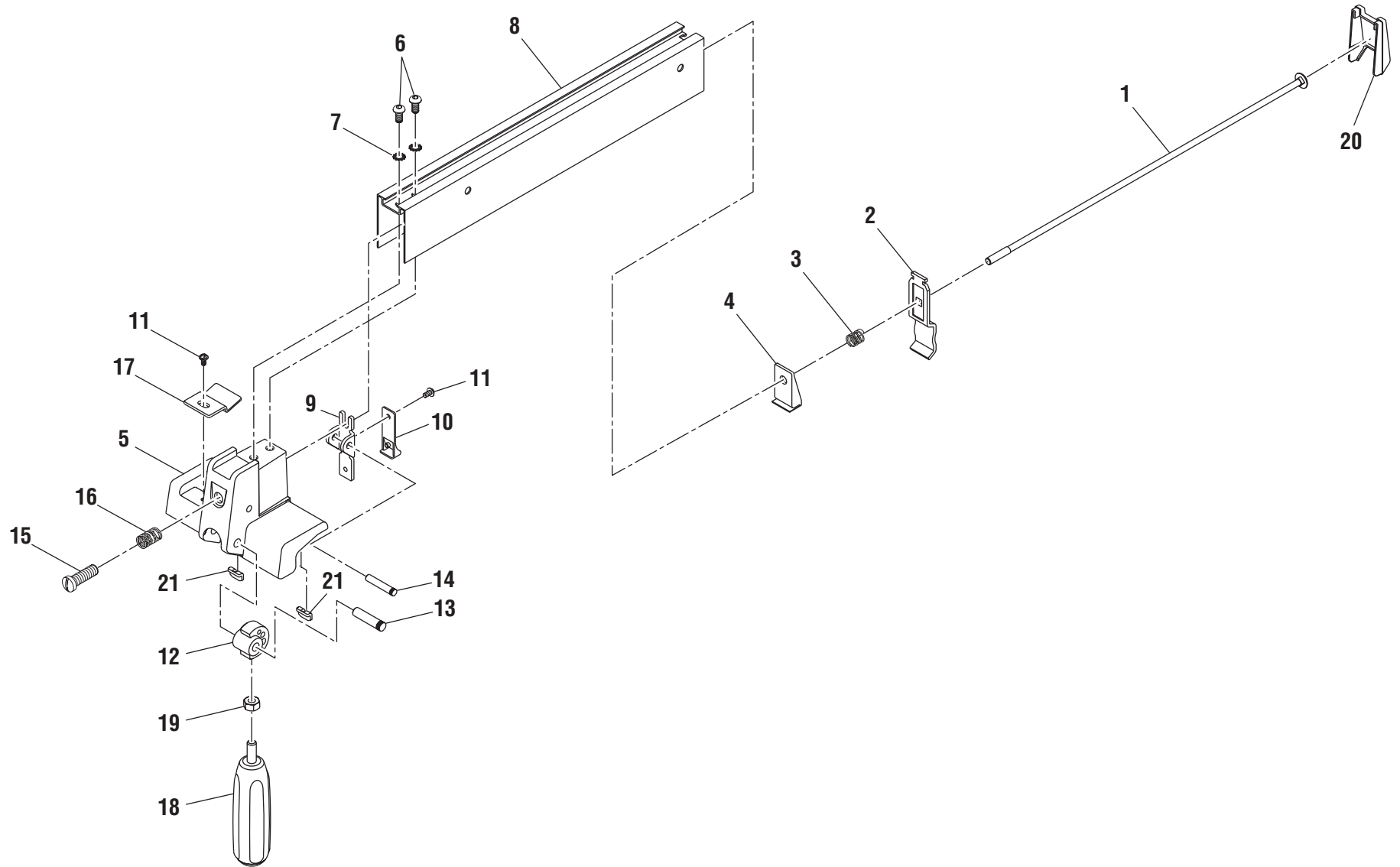

RYOBI 10 in. (254 mm) BAND SAW – MODEL NUMBER BS1001SV

The model number will be found on a plate attached to the motor housing. Always mention the model number in all correspondence regarding your **BAND SAW** or when ordering repair parts.

PARTS LIST - FIGURE E

Key No.	Part Number	Description	Qty.
1	290274-001	CLAMP ROD	1
2	270777-000	REAR CLAMP	1
3	029136-000	SPRING	1
4	303156-000	REAR SLIDING PAD	1
5	225315-000	RIP FENCE HOUSING	1
6	020624-000	* SCREW (M6 X 12 mm)	2
7	021300-002	LOCK WASHER	2
8	203042-000	FENCE	1
9	270776-000	BRACKET FENCE CAM	1
10	303766-000	PROTECT PAD	1
11	020726-003	* SCREW (M4 X 8 mm)	2
12	060126-000	CAM	1
13	290305-000	CAMP PIN	1
14	290306-000	LEVER PIN	1
15	022119-001	REAR CLAMP SCREW	1
16	029135-000	SPRING	1
17	303749-000	INDICATOR	1
18	901141-000	HANDLE	1
19	022108-000	NUT	1
20	303751-000	FENCE COVER	1
21	303752-000	SLIDING PAD	2
	901142-000	RIP FENCE ASSEMBLY	1

WARNING: Improper repair of a double insulated tool can result in damage to the double insulation system possibly causing electrical shock or electrocution. Any repairs requiring disassembly of your tool requires safety testing and should only be performed by a Ryobi Authorized Service Center. For the service center nearest you call 1-800-525-2579.

* Standard Hardware Item – May Be Purchased Locally

FIGURE F

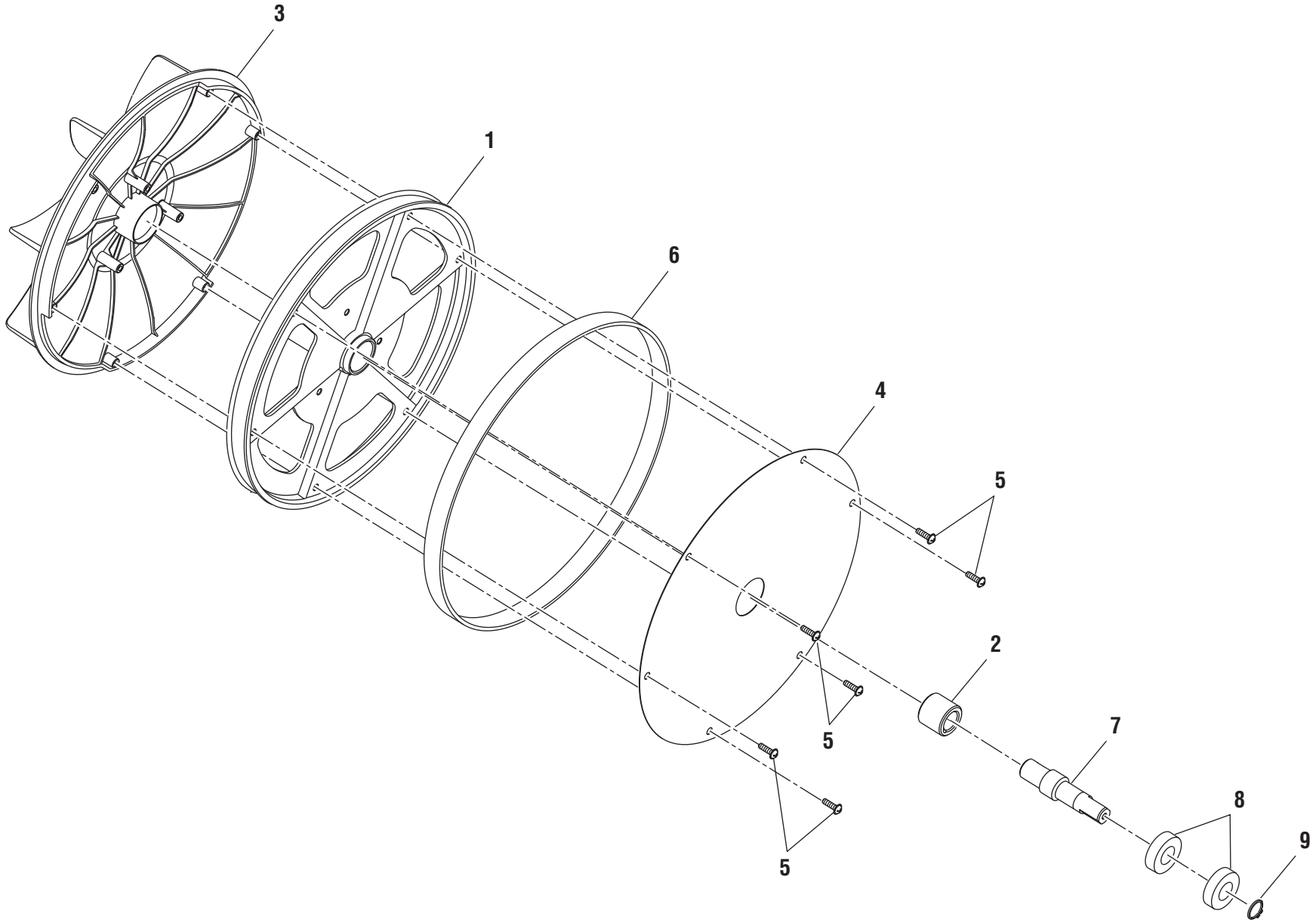

RYOBI 10 in. (254 mm) BAND SAW – MODEL NUMBER BS1001SV

The model number will be found on a plate attached to the motor housing. Always mention the model number in all correspondence regarding your **BAND SAW** or when ordering repair parts.

PARTS LIST - FIGURE F

Key No.	Part Number	Description	Qty.
1	225314-000	LOWERWHEEL	1
2	060125-000	SHAFT SHEATH	1
3	303753-000	FAN	1
4	916141-002	PVC STICKER	1
5	020132-000	* SCREW (M4 X 14 mm)	6
6	330077-000	WHEEL TIRE	1
7	290298-000	LOWERWHEEL SHAFT	1
8	050051-100	* BEARING (6002Z)	2
9	023108-001	* C-RING (S-15)	1
	901073-000	SHAFT ASSEMBLY (INCLUDES KEY NOS. 7-9)	

WARNING: Improper repair of a double insulated tool can result in damage to the double insulation system possibly causing electrical shock or electrocution. Any repairs requiring disassembly of your tool requires safety testing and should only be performed by a Ryobi Authorized Service Center. For the service center nearest you call 1-800-525-2579.

* Standard Hardware Item – May Be Purchased Locally

FIGURE G

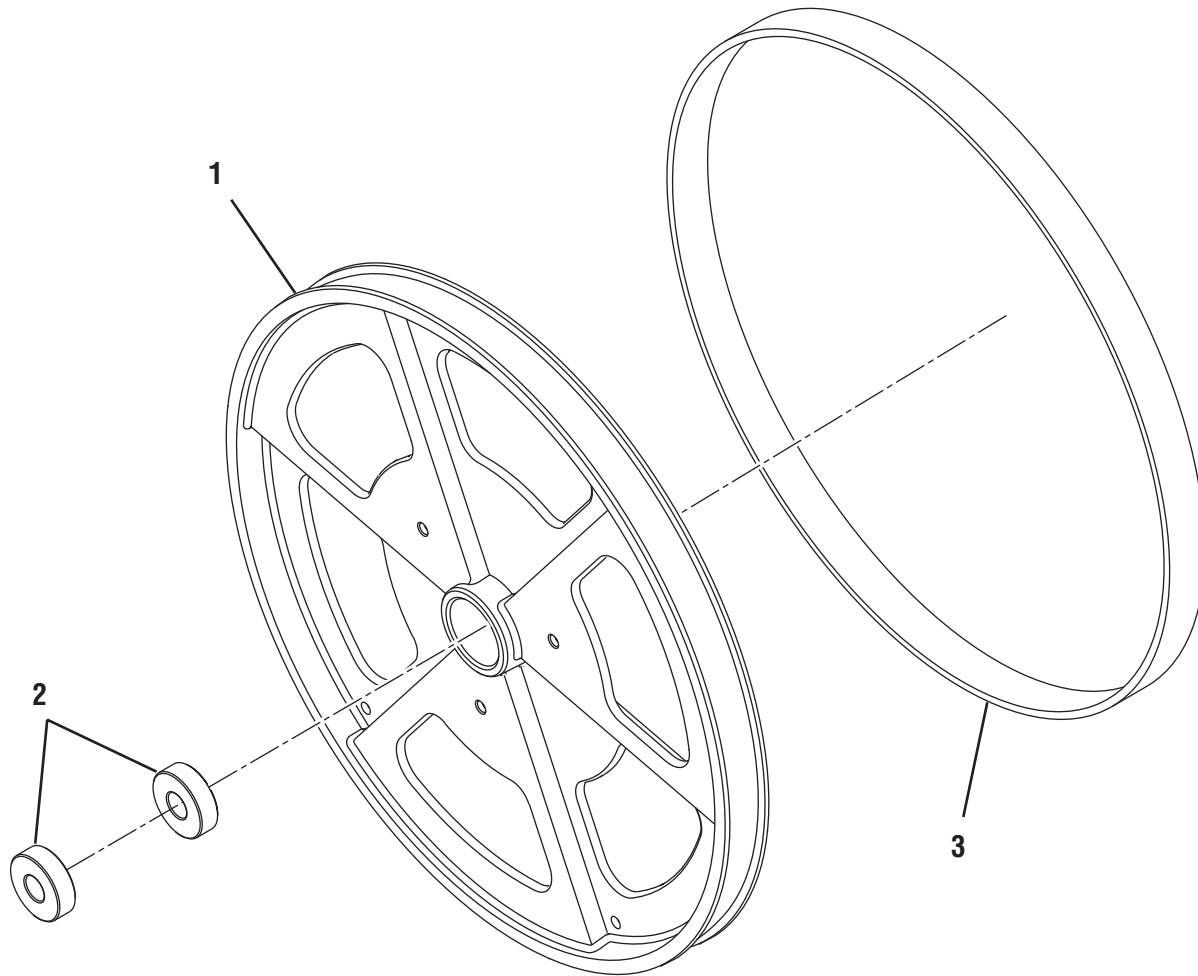

RYOBI 10 in. (254 mm) BAND SAW – MODEL NUMBER BS1001SV

The model number will be found on a plate attached to the motor housing. Always mention the model number in all correspondence regarding your **BAND SAW** or when ordering repair parts.

PARTS LIST - FIGURE G

Key No.	Part Number	Description	Qty.
1	225310-000	UPPERWHEEL	1
2	050013-000	BEARING (6000Z)	2
3	330077-000	TIREWHEEL	1

WARNING: Improper repair of a double insulated tool can result in damage to the double insulation system possibly causing electrical shock or electrocution. Any repairs requiring disassembly of your tool requires safety testing and should only be performed by a Ryobi Authorized Service Center. For the service center nearest you call 1-800-525-2579.

* Standard Hardware Item – May Be Purchased Locally

FIGURE H

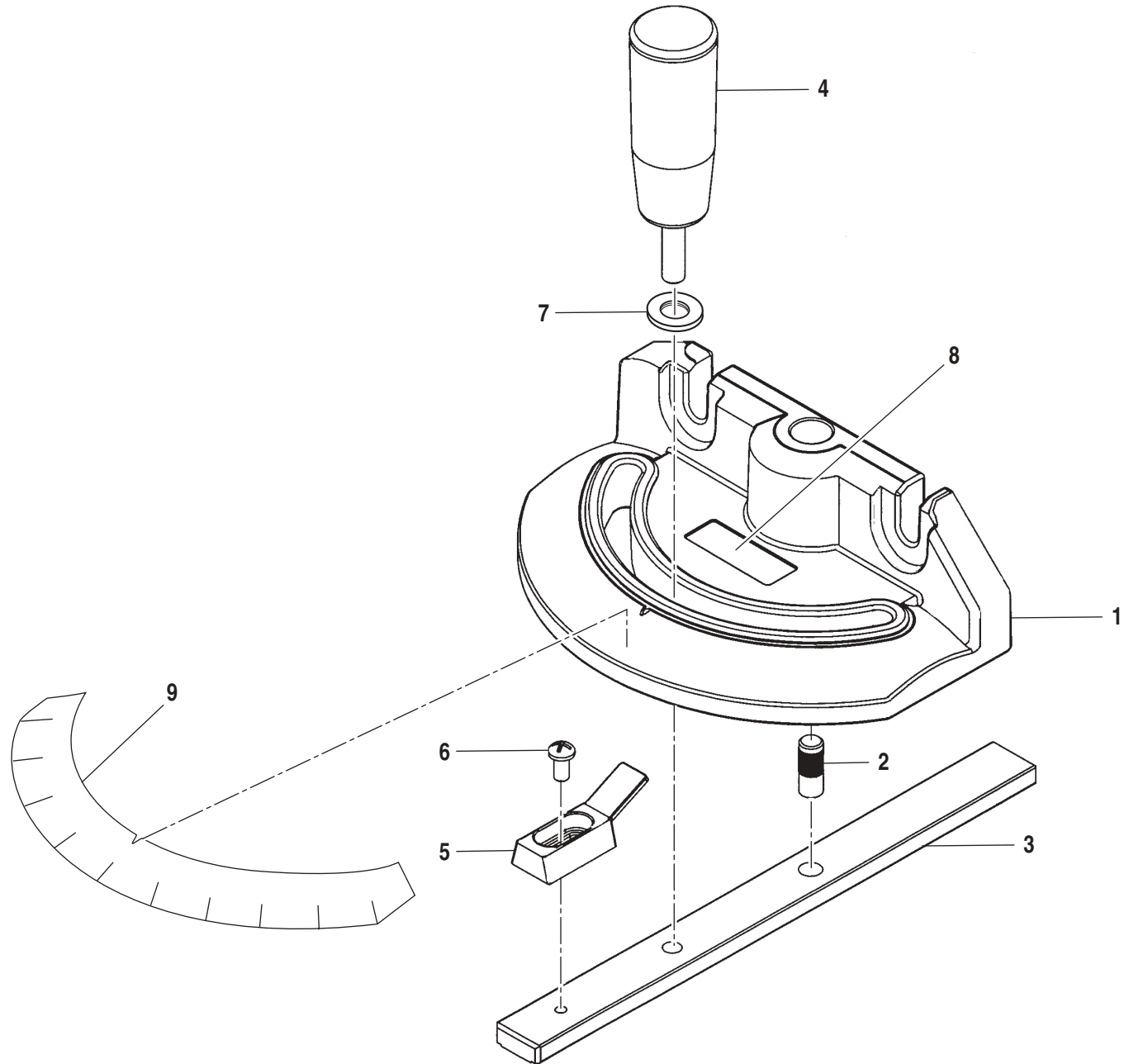

RYOBI 10 in. (254 mm) BAND SAW – MODEL NUMBER BS1001SV

The model number will be found on a plate attached to the motor housing. Always mention the model number in all correspondence regarding your **BAND SAW** or when ordering repair parts.

PARTS LIST FOR FIGURE H

Key No.	Part Number	Description	Qty.
	900988-000	MITER GAUGE ASSEMBLY	1
1	224074-000	MITER GAUGE	1
2	026205-001	PIN	1
3	203037-000	BAR	1
4	900990-000	MITER GAUGE KNOB	1
5	303663-000	INDICATOR	1
6	020103-031	* SEMS SCREW (M4 X 8 mm)	1
7	021101-039	WASHER	1
8	863209-006	LOGO PLATE	1
9	870037-002	MITER SCALE	1

WARNING: Improper repair of a double insulated tool can result in damage to the double insulation system possibly causing electrical shock or electrocution. Any repairs requiring disassembly of your tool requires safety testing and should only be performed by a Ryobi Authorized Service Center. For the service center nearest you call 1-800-525-2579.

* Standard Hardware Item – May Be Purchased Locally

FIGURE I

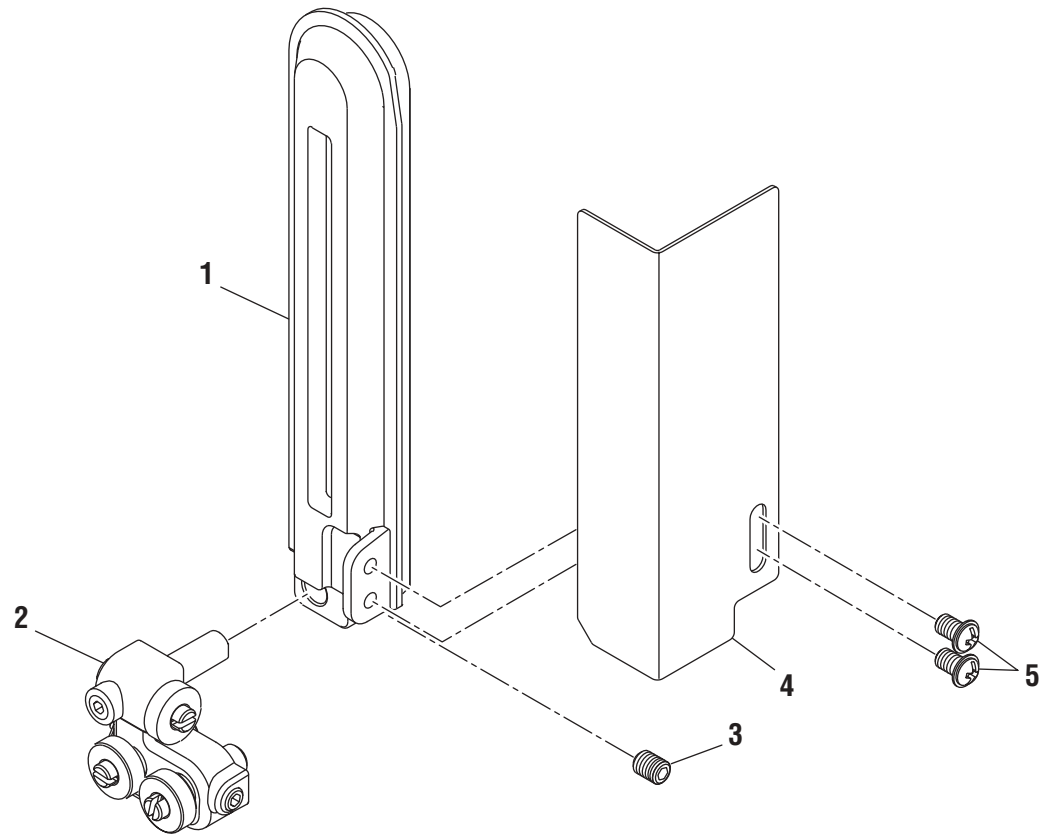

RYOBI 10 in. (254 mm) BAND SAW – MODEL NUMBER BS1001SV

The model number will be found on a plate attached to the motor housing. Always mention the model number in all correspondence regarding your **BAND SAW** or when ordering repair parts.

PARTS LIST FOR FIGURE I

Key No.	Part Number	Description	Qty.
1	225311-100	UPPER SLIDE	1
2	901075-000	SUPPORT GUIDE ASSEMBLY	1
3	020504-007	* SET SCREW (M6 X 8 mm)	1
4	270750-000	BLADE GUARD	1
5	020106-035	* SCREW (M5 X 8 mm)	2
	901072-000	BLADE GUIDE ASSEMBLY (INCLUDES KEY NOS. 1-5)	1

WARNING: Improper repair of a double insulated tool can result in damage to the double insulation system possibly causing electrical shock or electrocution. Any repairs requiring disassembly of your tool requires safety testing and should only be performed by a Ryobi Authorized Service Center. For the service center nearest you call 1-800-525-2579.

* Standard Hardware Item – May Be Purchased Locally

FIGURE J

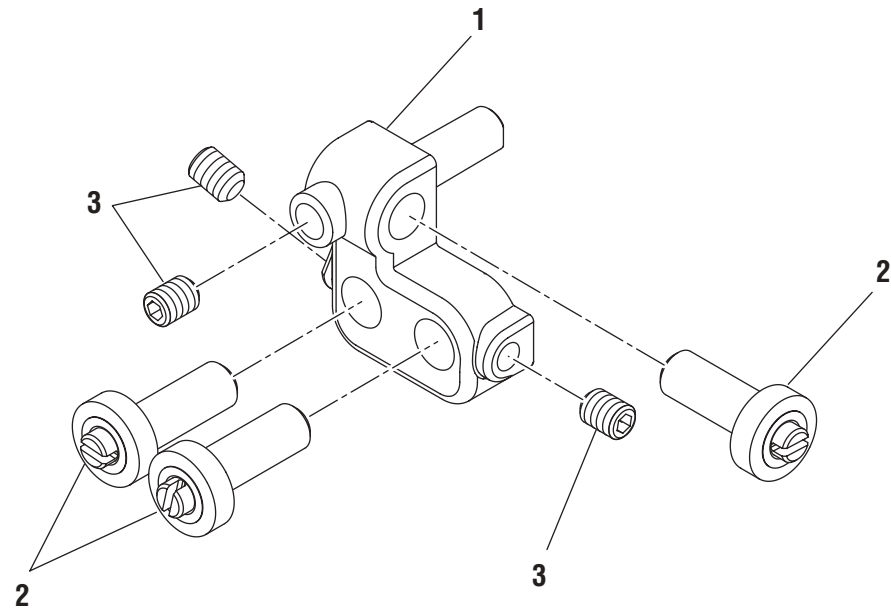

RYOBI 10 in. (254 mm) BAND SAW – MODEL NUMBER BS1001SV

The model number will be found on a plate attached to the motor housing. Always mention the model number in all correspondence regarding your **BAND SAW** or when ordering repair parts.

PARTS LIST FOR FIGURE J

Key No.	Part Number	Description	Qty.
1	260016-000	SUPPORT GUIDE	1
2	901077-000	BEARING SHAFT ASSEMBLY	3
3	020504-007	* SELF-TAPPING SCREW (M6 X 8 mm)	3
	901075-000	SUPPORT GUIDE ASSEMBLY (INCLUDES KEY NOS. 1-3)	1

WARNING: Improper repair of a double insulated tool can result in damage to the double insulation system possibly causing electrical shock or electrocution. Any repairs requiring disassembly of your tool requires safety testing and should only be performed by a Ryobi Authorized Service Center. For the service center nearest you call 1-800-525-2579.

* Standard Hardware Item – May Be Purchased Locally

FIGURE K

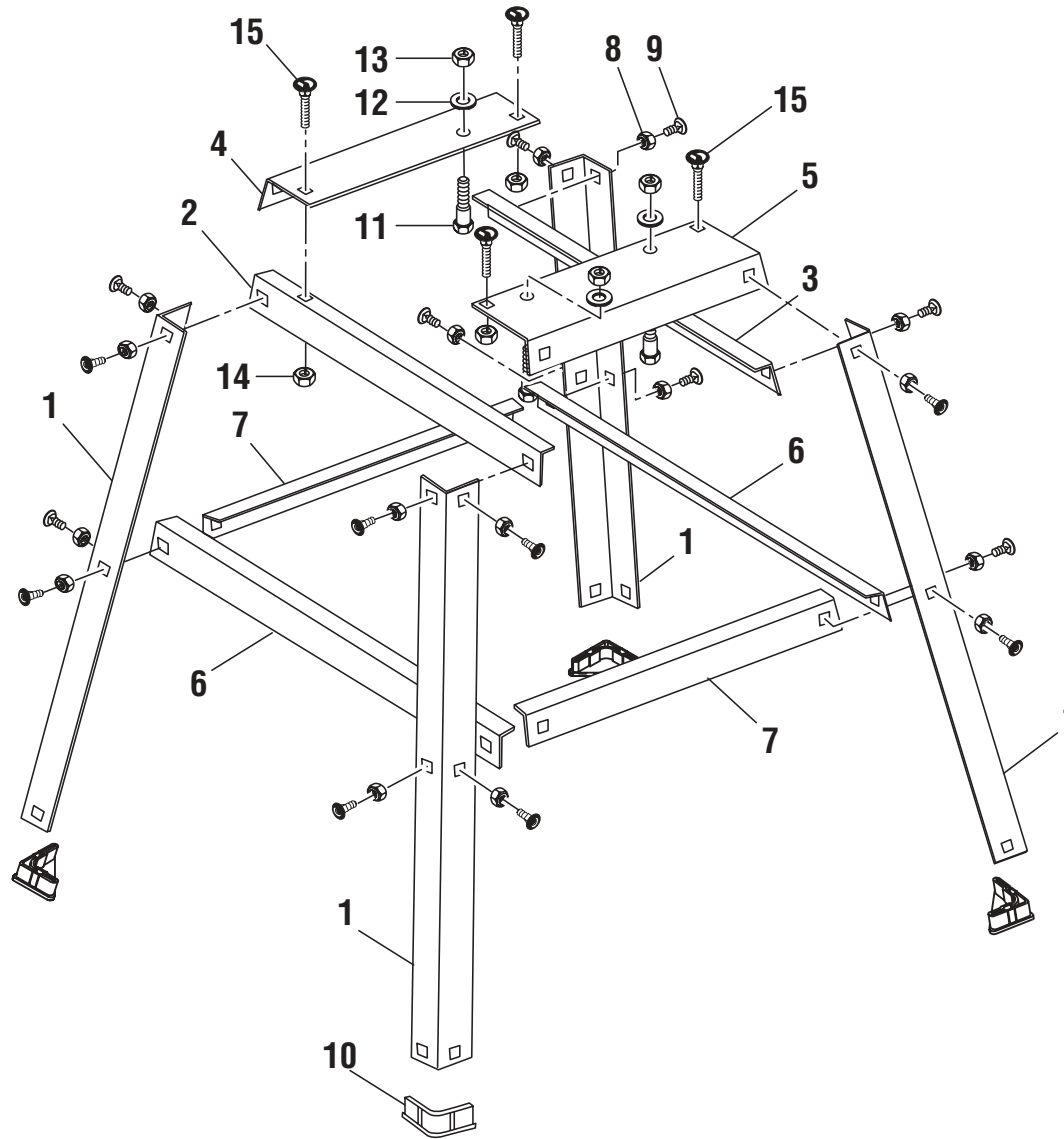

RYOBI 10 in. (254 mm) BAND SAW – MODEL NUMBER BS1001SV

The model number will be found on a plate attached to the motor housing. Always mention the model number in all correspondence regarding your **BAND SAW** or when ordering repair parts.

PARTS LIST FOR FIGURE K

Key No.	Part Number	Description	Qty.
1	270794-000	LEGS	4
2	270795-000	TOP BRACE - FRONT SIDE	1
3	270844-000	TOP BRACE - BACK SIDE	1
4	270796-000	TOP BRACE - LEFT SIDE	1
5	270799-000	TOP BRACE - RIGHT SIDE	1
6	270797-000	LEG BRACE - LONG SIDE	2
7	270798-000	LEG BRACE - SHORT SIDE	2
8	022126-001	HEX NUTS (5/16 in.)	16
9	028801-001	CARRIAGE BOLTS (5/16 in.)	16
10	303271-000	FEET	4
11	031010-001	MOUNTING BOLTS (M10 X 16 mm)	3
12	021109-027	FLATWASHERS	3
13	022102-001	HEX NUTS (M10 X 8L)	3
14	022134-001	HEX NUT (M6)	4
15	028805-001	CARRIAGE BOLT (M6 X 12)	4
	901181-000	LEG STAND ASSEMBLY	1

WARNING: Improper repair of a double insulated tool can result in damage to the double insulation system possibly causing electrical shock or electrocution. Any repairs requiring disassembly of your tool requires safety testing and should only be performed by a Ryobi Authorized Service Center. For the service center nearest you call 1-800-525-2579.

* Standard Hardware Item – May Be Purchased Locally