

**RYOBI  
BENCH GRINDER  
MODEL NO. BGH827  
REPAIR SHEET**

RYOBI BENCH GRINDER – MODEL NUMBER BGH827

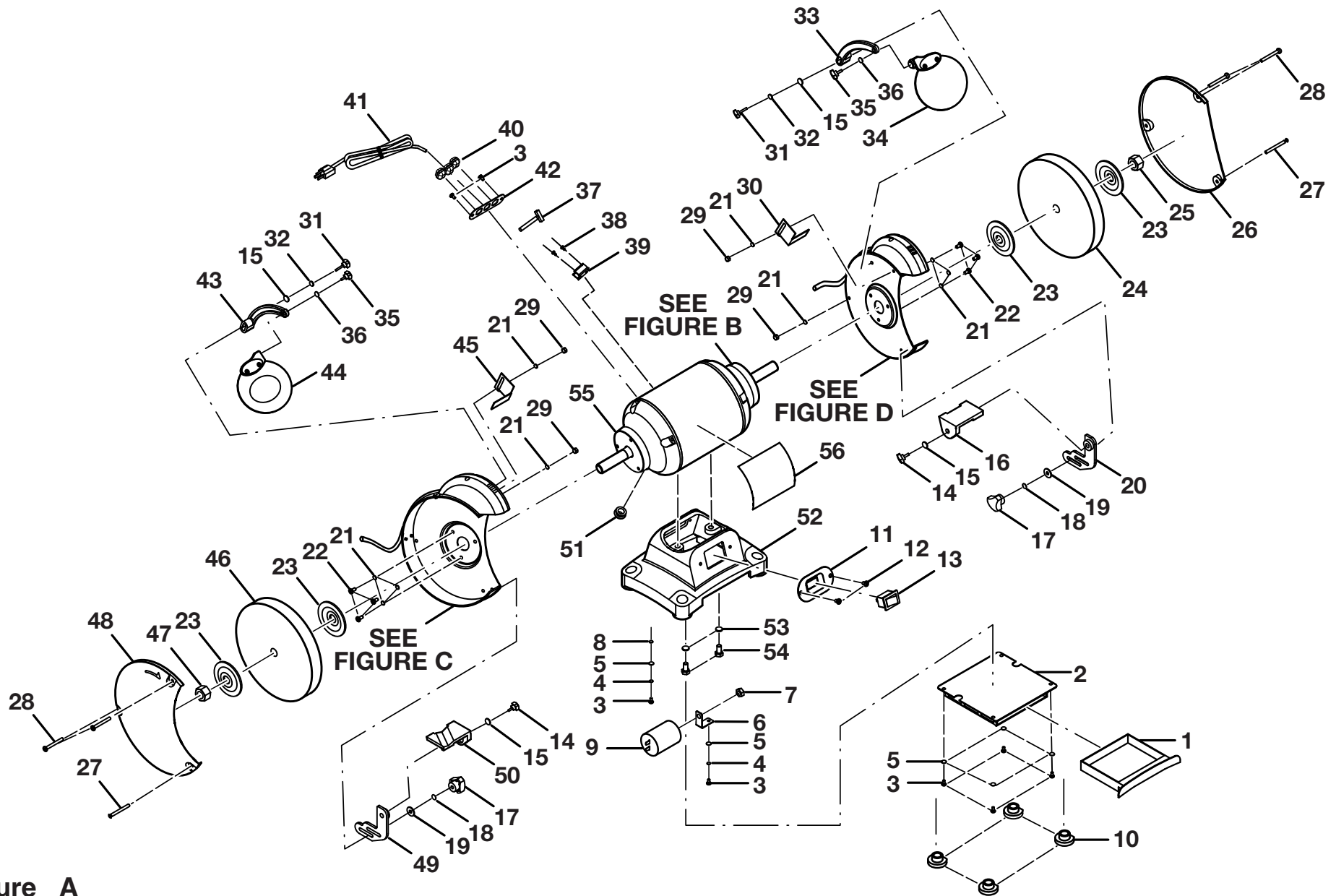

Figure A

## RYOBI BENCH GRINDER – MODEL NUMBER BGH827

The model number will be found on a plate attached to the motor housing. Always mention the model number in all correspondence regarding your **BENCH GRINDER** or when ordering repair parts.

### PARTS LIST (FIGURE A)

KEY NO.	PART NUMBER	DESCRIPTION	QTY	KEY NO.	PART NUMBER	DESCRIPTION	QTY
1	089150102001	COOLANT TRAY .....	1	31	089150100009	EYE SHIELD BRKT LOCK KNOB (M6 X 30 mm) ..	2
2	089150102704	COOLANT TRAY BASE ASSEMBLY .....	1	32	601104	* LOCK WASHER (6 mm) .....	2
3	602003	* SCREW (M4 X 8 mm PAN HD.) .....	8	33	089150100804	PLAIN EYE SHIELD MOUNTING POLE .....	1
4	601711	* LOCK WASHER (4 mm) .....	2	34	089150100805	EYE SHIELD ASSEMBLY .....	1
5	601610	* WASHER (4 mm) .....	6	35	089150100806	EYE SHIELD LOCK KNOB (M5 X 15 mm) .....	2
6	605601	CAPACITOR SUPPORT .....	1	36	600306	* WASHER (5 mm) .....	2
7	602401	* HEX NUT (M8) .....	1	37	089150102007	DIAMOND WHEEL DRESSING TOOL .....	1
8	602601	TOOTHED LOCK WASHER (4 mm) .....	1	38	089150100024	* SCREW (M4 X 6 mm PAN HD.) .....	2
9	089150102002	CAPACITOR (25uF/300V) .....	1	39	089150102009	WHEEL DRESSING TOOL CLIP .....	1
10	089150102003	RUBBER FOOT .....	4	40	602201	CORD CLAMP .....	3
11	605101	SWITCH PLATE .....	1	41	602301	POWER CORD .....	1
12	604704	* SCREW (M5 X 8 mm PAN HD.) .....	2	42	089150100010	POWER CORD FIXING BOARD .....	1
13	602101	SWITCH .....	1	43	089150100807	MAGNIFIED EYE SHIELD MTG. POLE .....	1
14	089150100801	WORK REST LOCK KNOB (M6 X 17 mm) .....	2	44	089150100808	MAGNIFIED EYE SHIELD ASSEMBLY .....	1
15	601204	* WASHER (6 mm) .....	4	45	089150102010	LEFT SPARK DEFLECTOR .....	1
16	089150102004	RIGHT WORK REST .....	1	46	806002	WHEEL (60 GRIT) .....	1
17	089150100003	WORK REST LOCK NUT (M5) .....	2	47	800401	HEX NUT LEFT HAND (M16) .....	1
18	089150100004	TOOTHED LOCK WASHER .....	2	48	089150102011	LEFT WHEEL COVER .....	1
19	602704	* WASHER (5 mm) .....	2	49	089150100810	LEFT MOVABLE WORK REST .....	1
20	089150100802	RIGHT MOVABLE WORK REST .....	1	50	089150102801	LEFT WORK REST .....	1
21	600212	* LOCK WASHER (5 mm) .....	10	51	601901	CORD BUSHING .....	1
22	600112	* SCREW (M5 X 10 mm PAN HD.) .....	6	52	089150102014	BASE .....	1
23	800504	WHEEL FLANGE .....	4	53	089150102013	* SPRING WASHER (D8 X 12.5 mm) .....	2
24	803602	WHEEL (36 GRIT) .....	1	54	089150102012	* HEX NUT (M8 X 20 mm) .....	2
25	802601	* HEX NUT (M16) .....	1	55	089150102701	MOTOR ASSEMBLY (SEE FIGURE B) .....	1
26	089150102005	RIGHT WHEEL GUARD COVER .....	1	56	089150102901	LOGO & DATA LABEL .....	1
27	089150100006	* CARRRIAGE BOLT (M5 X 51 mm) .....	2	57	089150100902	BULB WATTAGE LABEL-LH (NOT SHOWN) ..	1
28	089150100007	* SCREW (M5 X 48 mm PAN HD.) .....	4	58	089150100903	BULB WATTAGE LABEL-RH (NOT SHOWN) ..	1
29	600506	* HEX NUT (M5) .....	4		983000626	OPERATOR'S MANUAL	
30	089150102006	RIGHT SPARK DEFLECTOR .....	1		983000626R	REPAIR SHEET (REV:00)	
					01-18-05		

**WARNING: Improper repair of a double insulated tool can result in damage to the double insulation system possibly causing electrical shock or electrocution. Any repairs requiring disassembly of your tool requires safety testing and should only be performed by a Ryobi Authorized Service Center. For the service center nearest you call 1-800-525-2579.**

\* STANDARD HARDWARE ITEM – MAY BE PURCHASED LOCALLY

RYOBI BENCH GRINDER – MODEL NUMBER BGH827

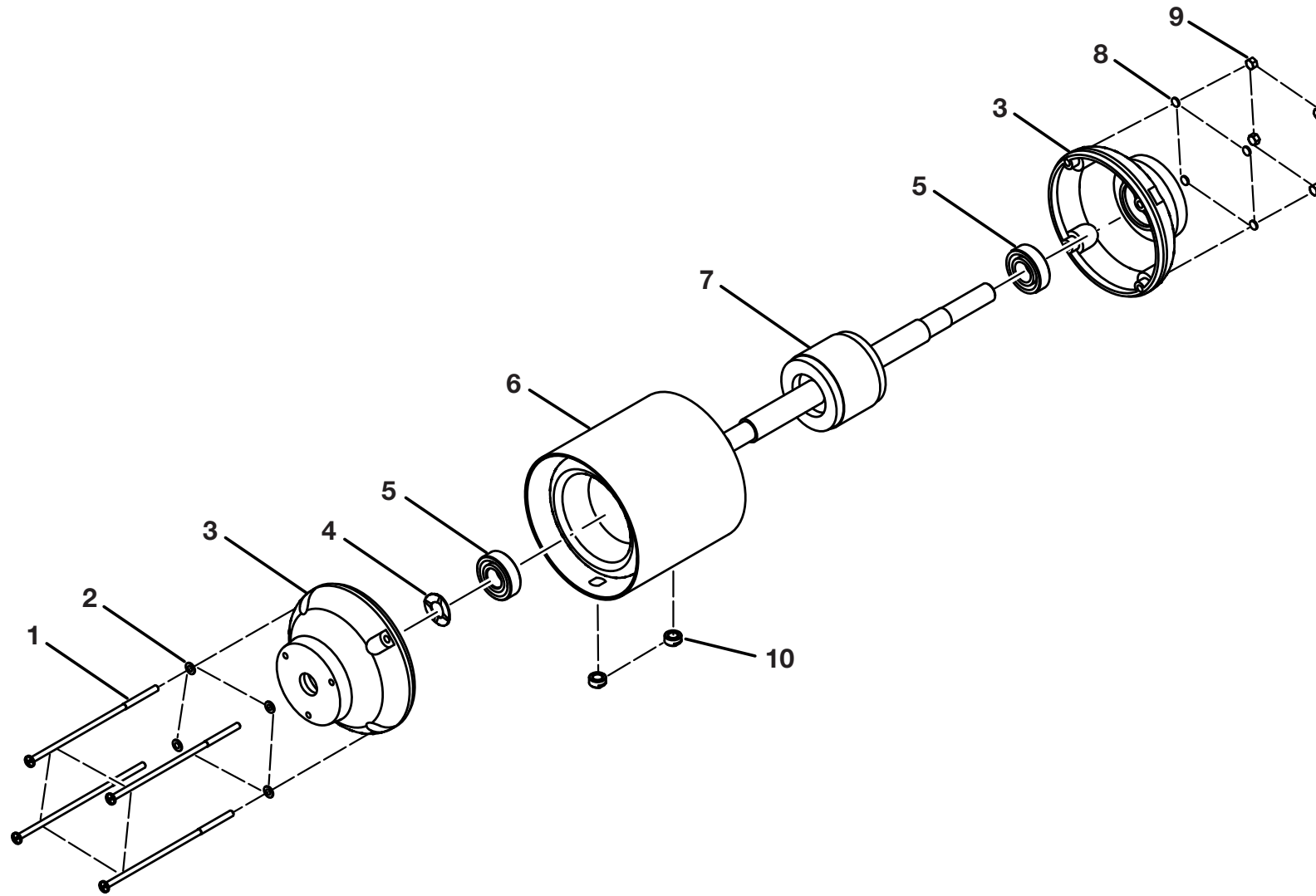

Figure B

**RYOBI BENCH GRINDER – MODEL NUMBER BGH827**

The model number will be found on a plate attached to the motor housing. Always mention the model number in all correspondence regarding your **BENCH GRINDER** or when ordering repair parts.

**PARTS LIST (FIGURE B)**

<b>KEY NO.</b>	<b>PART NUMBER</b>	<b>DESCRIPTION</b>	<b>QTY</b>
1	089150102015	* SCREW (M5 X 148 mm PAN HD.) .....	4
2	600306	* WASHER (5 mm) .....	4
3	089150102016	END CAPS (HT150) .....	2
4	801101	WAVY WASHER (D40) .....	1
5	801302	BALL BEARING .....	2
6	089150102017	FIELD .....	1
7	089150102018	ARMATURE .....	1
8	600212	* LOCK WASHER (5 mm) .....	4
9	600506	* HEX NUT (M5) .....	4
10	089150102019	SPECIAL NUT .....	2

**WARNING: Improper repair of a double insulated tool can result in damage to the double insulation system possibly causing electrical shock or electrocution. Any repairs requiring disassembly of your tool requires safety testing and should only be performed by a Ryobi Authorized Service Center. For the service center nearest you call 1-800-525-2579.**

\* STANDARD HARDWARE ITEM – MAY BE PURCHASED LOCALLY

RYOBI BENCH GRINDER – MODEL NUMBER BGH827

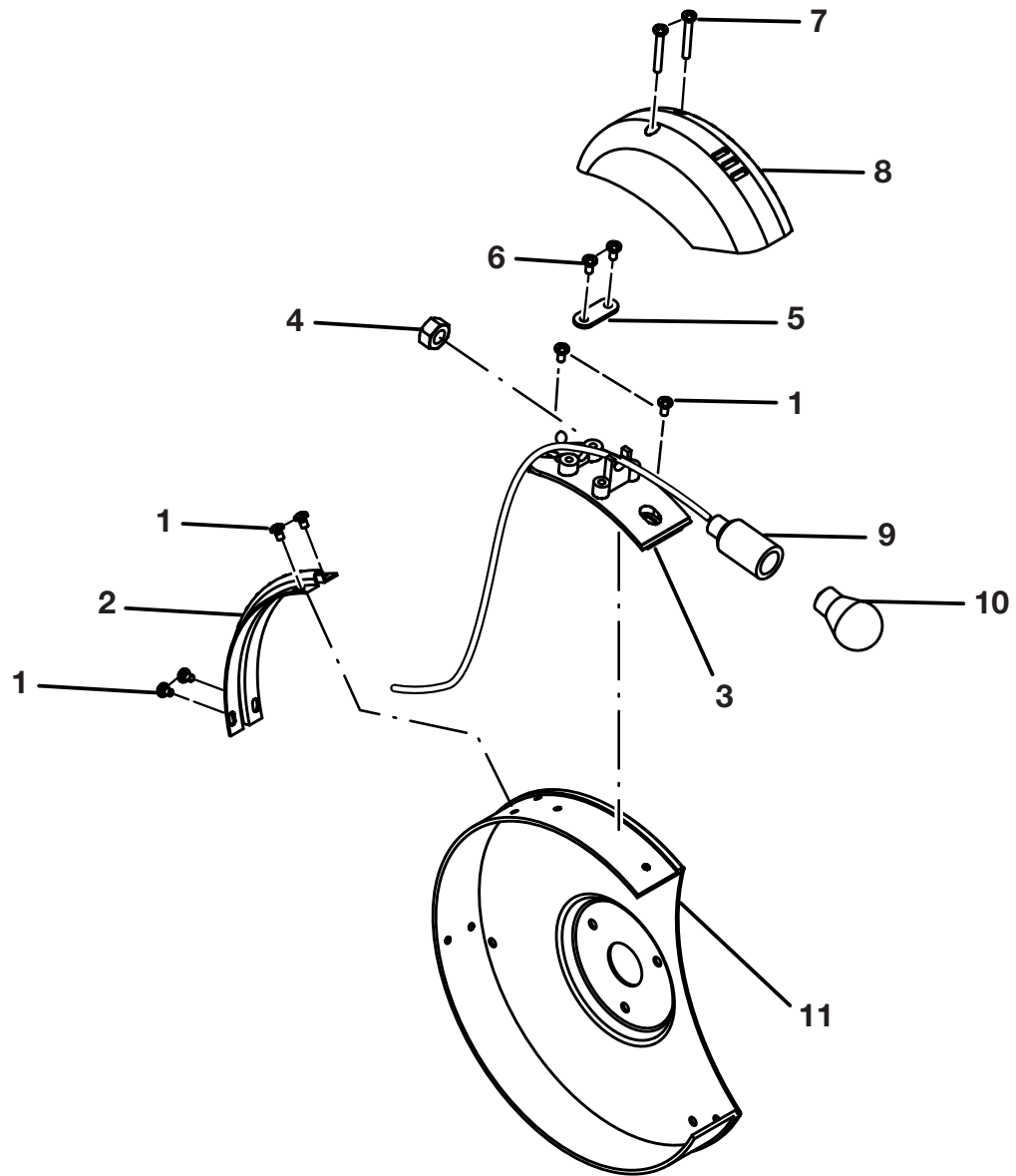

Figure C

**RYOBI BENCH GRINDER – MODEL NUMBER BGH827**

The model number will be found on a plate attached to the motor housing. Always mention the model number in all correspondence regarding your **BENCH GRINDER** or when ordering repair parts.

**PARTS LIST (FIGURE C)**

<b>KEY NO.</b>	<b>PART NUMBER</b>	<b>DESCRIPTION</b>	<b>QTY</b>
1	089150100024	* SCREW (M4 X 6 mm PAN HD.).....	6
2	089150102020	LAMP CORD PRESSURE PLATE.....	1
3	089150102021	LAMP BASE .....	1
4	089150100020	LAMP SOCKET FIXING NUT.....	1
5	089150100021	LAMP CORD FIXING PLATE .....	1
6	601504	* SCREW (M4 X 10 mm PAN HD.).....	2
7	089150100022	* SCREW (M4 X 30 mm PAN HD.).....	2
8	089150100023	LAMP COVER .....	1
9	089150100025	LAMP SOCKET W/CORD .....	1
10	See Description	BULB (12V) No. 93 OR No. 1003 AVAILABLE AT LOCAL AUTO PARTS STORE.....	1
11	089150102022	LEFT WHEEL GUARD .....	1

**WARNING: Improper repair of a double insulated tool can result in damage to the double insulation system possibly causing electrical shock or electrocution. Any repairs requiring disassembly of your tool requires safety testing and should only be performed by a Ryobi Authorized Service Center. For the service center nearest you call 1-800-525-2579.**

\* STANDARD HARDWARE ITEM – MAY BE PURCHASED LOCALLY

RYOBI BENCH GRINDER – MODEL NUMBER BGH827

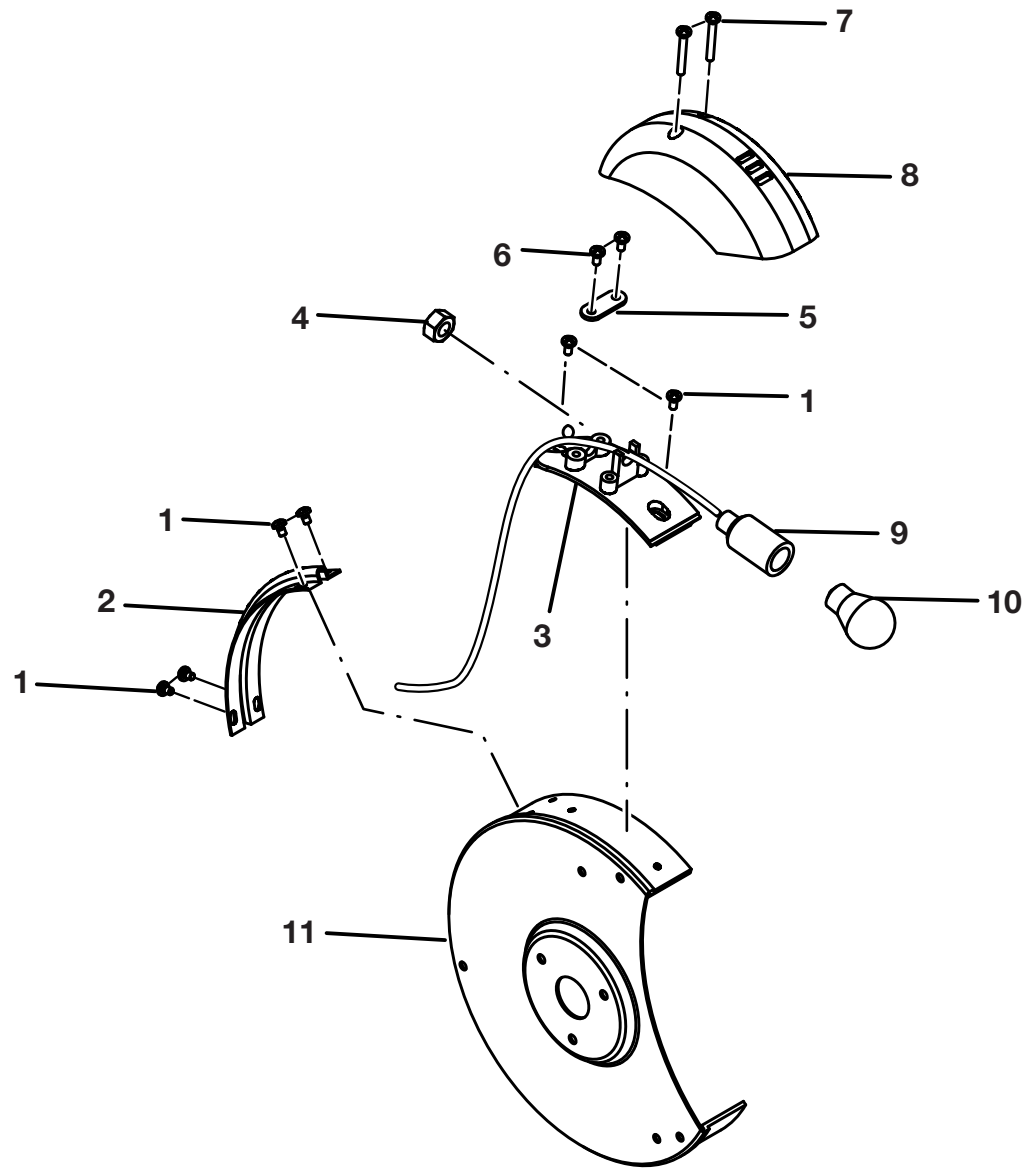

Figure D



**RYOBI BENCH GRINDER – MODEL NUMBER BGH827**

The model number will be found on a plate attached to the motor housing. Always mention the model number in all correspondence regarding your **BENCH GRINDER** or when ordering repair parts.

**PARTS LIST (FIGURE D)**

KEY NO.	PART NUMBER	DESCRIPTION	QTY
1	089150100024	* SCREW (M4 X 6 mm PAN HD.).....	6
2	089150102020	LAMP CORD PRESSURE PLATE.....	1
3	089150102021	LAMP BASE .....	1
4	089150100020	LAMP SOCKET FIXING NUT.....	1
5	089150100021	LAMP CORD FIXING PLATE .....	1
6	601504	* SCREW (M4 X 10 mm PAN HD.).....	2
7	089150100022	* SCREW (M4 X 30 mm PAN HD.).....	2
8	089150100023	LAMP COVER .....	1
9	089150100025	LAMP SOCKET W/CORD .....	1
10	See Description	BULB (12V) No. 93 OR No. 1003 AVAILABLE AT LOCAL AUTO PARTS STORE.....	1
11	089150102023	RIGHT WHEEL GUARD .....	1

**WARNING: Improper repair of a double insulated tool can result in damage to the double insulation system possibly causing electrical shock or electrocution. Any repairs requiring disassembly of your tool requires safety testing and should only be performed by a Ryobi Authorized Service Center. For the service center nearest you call 1-800-525-2579.**

\* STANDARD HARDWARE ITEM – MAY BE PURCHASED LOCALLY