

**RYOBI
BENCH GRINDER
MODEL NO. BGH616
REPAIR SHEET**

RYOBI BENCH GRINDER – MODEL NUMBER BGH616

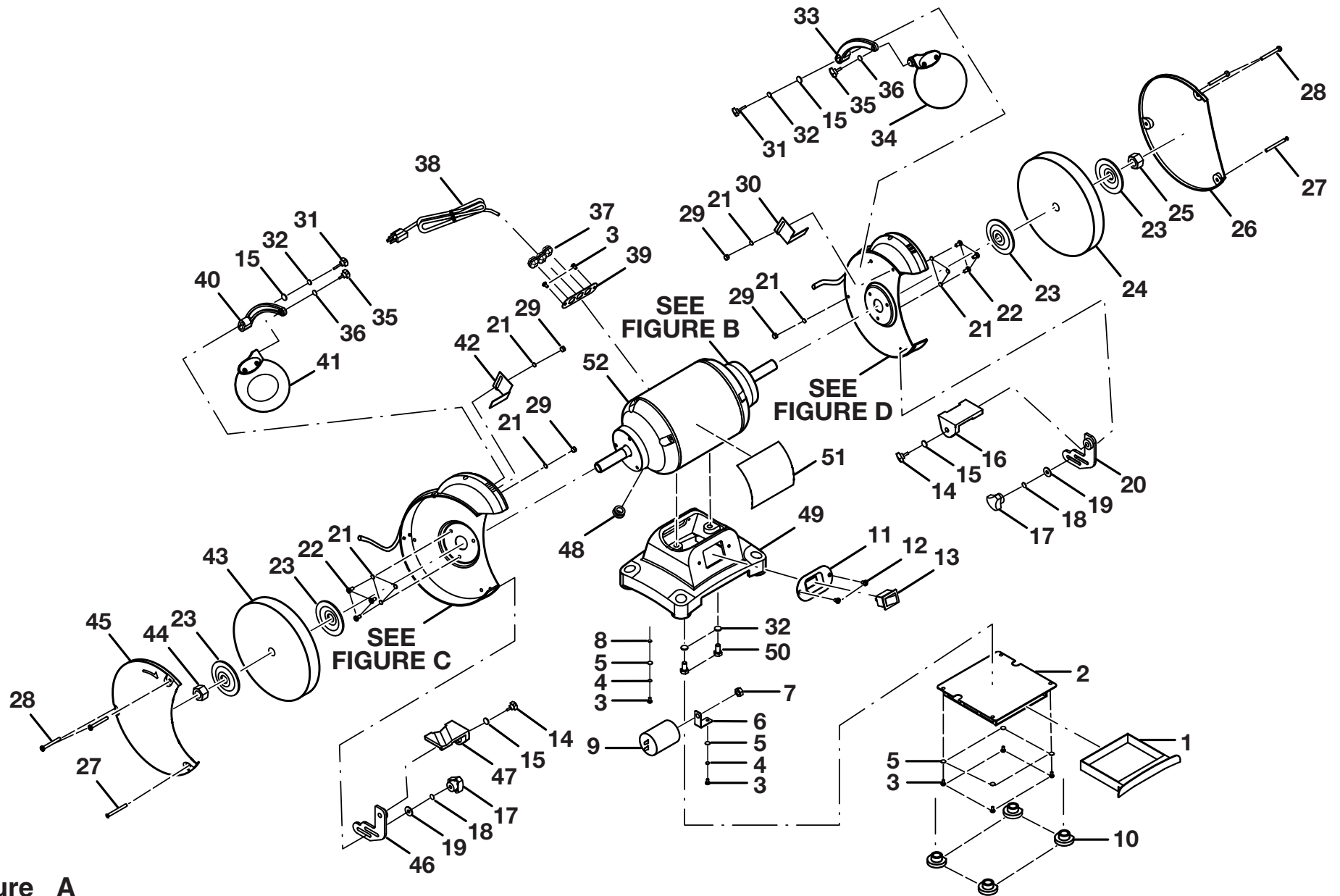

Figure A

RYOBI BENCH GRINDER – MODEL NUMBER BGH616

The model number will be found on a plate attached to the motor housing. Always mention the model number in all correspondence regarding your **BENCH GRINDER** or when ordering repair parts.

PARTS LIST (FIGURE A)

KEY NO.	PART NUMBER	DESCRIPTION	QTY	KEY NO.	PART NUMBER	DESCRIPTION	QTY
1	089150100001	COOLANT TRAY	1	30	089150100008	RIGHT SPARK DEFLECTOR	1
2	089150100704	COOLANT TRAY BASE ASSEMBLY	1	31	089150100009	EYE SHIELD BRKT LOCK KNOB (M6 X 30 mm)	2
3	602003	* SCREW (M4 X 8 mm PAN HD.)	8	32	601104	* LOCK WASHER (6 mm)	4
4	601711	* LOCK WASHER (4 mm)	2	33	089150100804	PLAIN EYE SHIELD MOUNTING POLE	1
5	601610	* WASHER (4 mm)	6	34	089150100805	EYE SHIELD ASSEMBLY	1
6	605601	CAPACITOR SUPPORT	1	35	089150100806	EYE SHIELD LOCK KNOB (M5 X 15 mm)	2
7	602401	* HEX NUT (M8)	1	36	600306	* WASHER (5 mm)	2
8	602601	TOOTHED LOCK WASHER (4 mm)	1	37	602201	CORD CLAMP	3
9	603201	CAPACITOR (8uF/300V)	1	38	602301	POWER CORD	1
10	089150100002	RUBBER FOOT	4	39	089150100010	POWER CORD FIXING BOARD	1
11	605101	SWITCH PLATE	1	40	089150100807	MAGNIFIED EYE SHIELD MTG. POLE	1
12	604704	* SCREW (M5 X 8 mm PAN HD.)	2	41	089150100808	MAGNIFIED EYE SHIELD ASSEMBLY	1
13	602101	SWITCH	1	42	089150100011	LEFT SPARK DEFLECTOR	1
14	089150100801	WORK REST LOCK KNOB (M6 X 17 mm)	2	43	606001	WHEEL (60#, 150 X 20 X 12.7 mm)	1
15	601204	* WASHER (6 mm)	4	44	602801	HEX NUT LEFT HAND (M12)	1
16	089150100802	RIGHT MOVABLE WORK REST	1	45	089150100012	LEFT WHEEL COVER	1
17	089150100003	WORK REST LOCK NUT (M5)	2	46	089150100809	LEFT WORK REST	1
18	089150100004	TOOTHED LOCK WASHER	2	47	089150100810	LEFT MOVABLE WORK REST	1
19	602704	* WASHER (5 mm)	2	48	601901	CORD BUSHING	1
20	089150100803	RIGHT WORK REST	1	49	089150100016	BASE (HT 150)	1
21	600212	* LOCK WASHER (5 mm)	10	50	605202	* SCREW (M6 X 20 mm)	2
22	600112	* SCREW (M5 X 10 mm PAN HD.)	6	51	089150100901	LOGO & DATA LABEL	1
23	602904	WHEEL FLANGE	4	52	089150100701	MOTOR ASSEMBLY (SEE FIGURE B)	1
24	603601	WHEEL (36#, 150 X 20 X 12.7 mm)	1	53	089150100902	BULB WATTAGE LABEL-LH (NOT SHOWN) ..	1
25	605001	* HEX NUT (M12)	1	54	089150100903	BULB WATTAGE LABEL-RH (NOT SHOWN) ..	1
26	089150100005	RIGHT WHEEL GUARD COVER	1		983000626	OPERATOR'S MANUAL (NOT SHOWN)	
27	089150100006	* CARRRIAGE BOLT (M5 X 51 mm)	2		983000626R	REPAIR SHEET (REV:00)	
28	089150100007	* SCREW (M5 X 48 mm PAN HD.)	4		01-18-05		
29	600506	* HEX NUT (M5)	4				

WARNING: Improper repair of a double insulated tool can result in damage to the double insulation system possibly causing electrical shock or electrocution. Any repairs requiring disassembly of your tool requires safety testing and should only be performed by a Ryobi Authorized Service Center. For the service center nearest you call 1-800-525-2579.

* STANDARD HARDWARE ITEM – MAY BE PURCHASED LOCALLY

RYOBI BENCH GRINDER – MODEL NUMBER BGH616

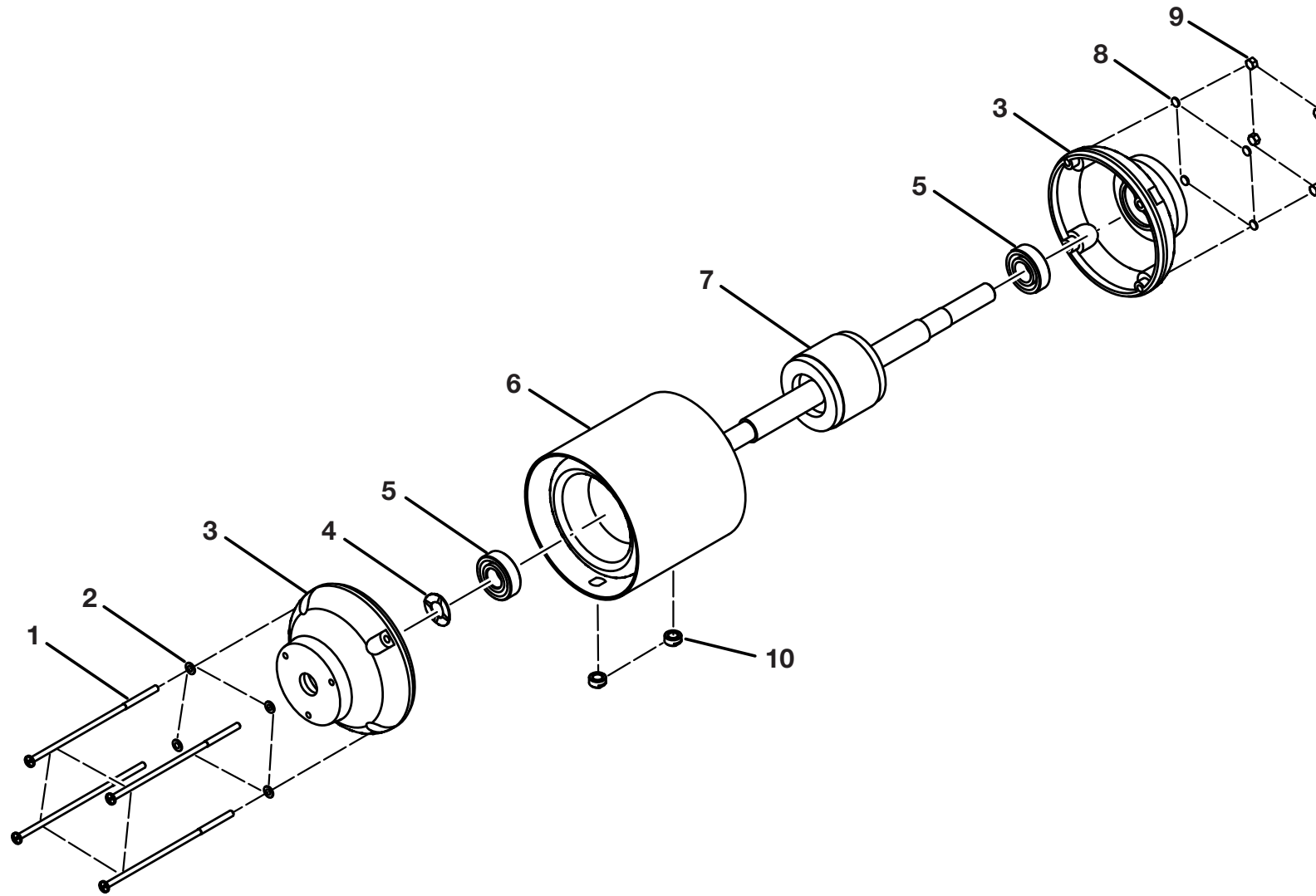

Figure B

RYOBI BENCH GRINDER – MODEL NUMBER BGH616

The model number will be found on a plate attached to the motor housing. Always mention the model number in all correspondence regarding your **BENCH GRINDER** or when ordering repair parts.

PARTS LIST (FIGURE B)

KEY NO.	PART NUMBER	DESCRIPTION	QTY
1	604104	* SCREW (M4 X 118 mm PAN HD.).....	4
2	601610	* WASHER (4 mm).....	4
3	089150100013	END CAPS (ADC12)	2
4	603001	WAVY WASHER (D35)	1
5	603101	BALL BEARING.....	2
6	089150100014	FIELD	1
7	089150100015	ARMATURE	1
8	601711	* LOCK WASHER (4 mm)	4
9	601808	* HEX NUT (M4)	4
10	604502	SPECIAL NUT	2

WARNING: Improper repair of a double insulated tool can result in damage to the double insulation system possibly causing electrical shock or electrocution. Any repairs requiring disassembly of your tool requires safety testing and should only be performed by a Ryobi Authorized Service Center. For the service center nearest you call 1-800-525-2579.

* STANDARD HARDWARE ITEM – MAY BE PURCHASED LOCALLY

RYOBI BENCH GRINDER – MODEL NUMBER BGH616

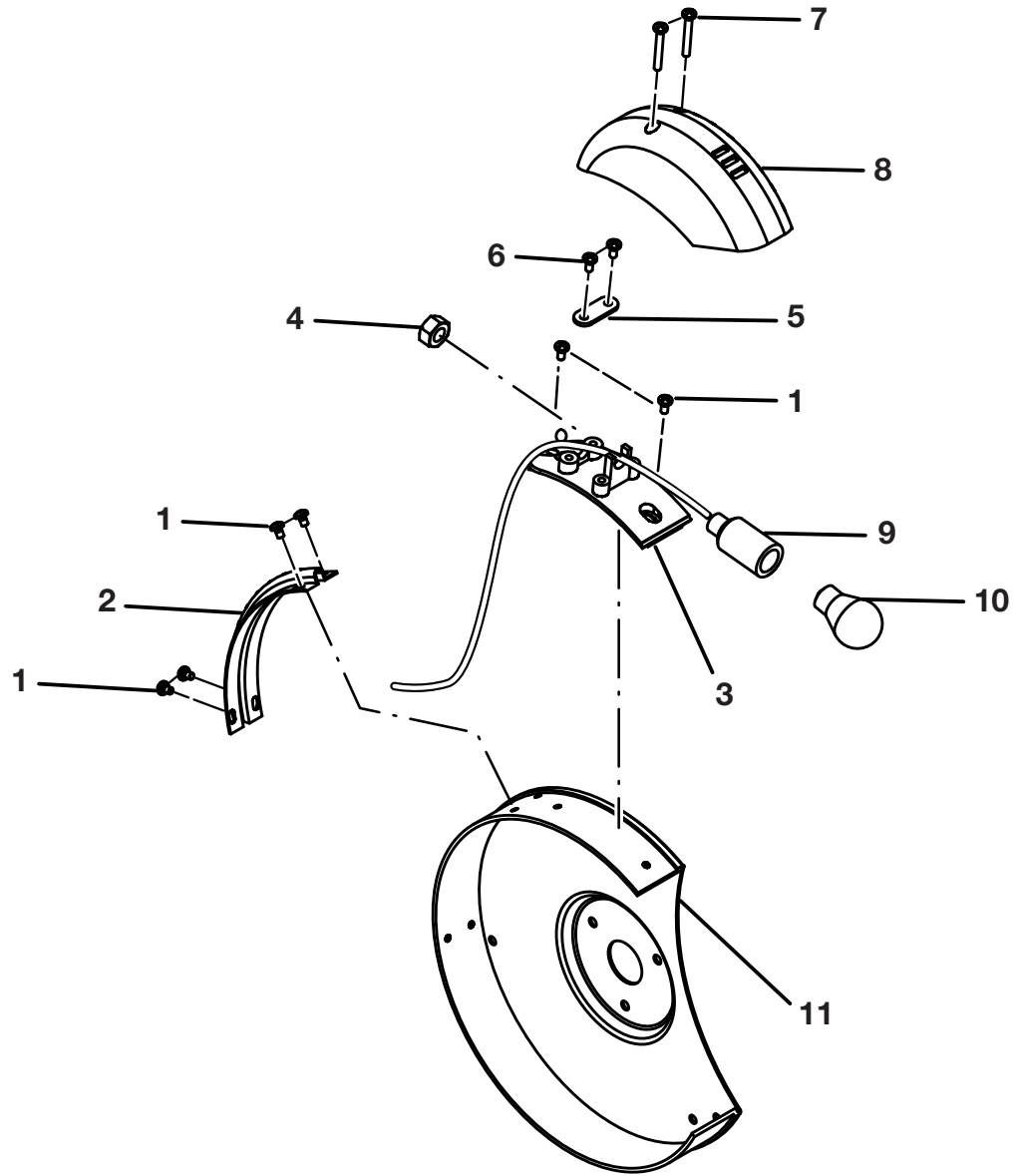

Figure C

RYOBI BENCH GRINDER – MODEL NUMBER BGH616

The model number will be found on a plate attached to the motor housing. Always mention the model number in all correspondence regarding your **BENCH GRINDER** or when ordering repair parts.

PARTS LIST (FIGURE C)

KEY NO.	PART NUMBER	DESCRIPTION	QTY
1	089150100024	* SCREW (M4 X 6 mm PAN HD.).....	6
2	089150100018	LAMP CORD PRESSURE PLATE.....	1
3	089150100019	LAMP BASE.....	1
4	089150100020	LAMP SOCKET FIXING NUT.....	1
5	089150100021	LAMP CORD FIXING PLATE.....	1
6	601504	* SCREW (M4 X 10 mm PAN HD.).....	2
7	089150100022	* SCREW (M4 X 30 mm PAN HD.).....	2
8	089150100023	LAMP COVER.....	1
9	089150100025	LAMP SOCKET W/CORD.....	1
10	See Description	BULB (12V) No. 93 OR No. 1003 AVAILABLE AT LOCAL AUTO PARTS STORE.....	1
11	089150100027	LEFT WHEEL GUARD.....	1

WARNING: Improper repair of a double insulated tool can result in damage to the double insulation system possibly causing electrical shock or electrocution. Any repairs requiring disassembly of your tool requires safety testing and should only be performed by a Ryobi Authorized Service Center. For the service center nearest you call 1-800-525-2579.

* STANDARD HARDWARE ITEM – MAY BE PURCHASED LOCALLY

RYOBI BENCH GRINDER – MODEL NUMBER BGH616

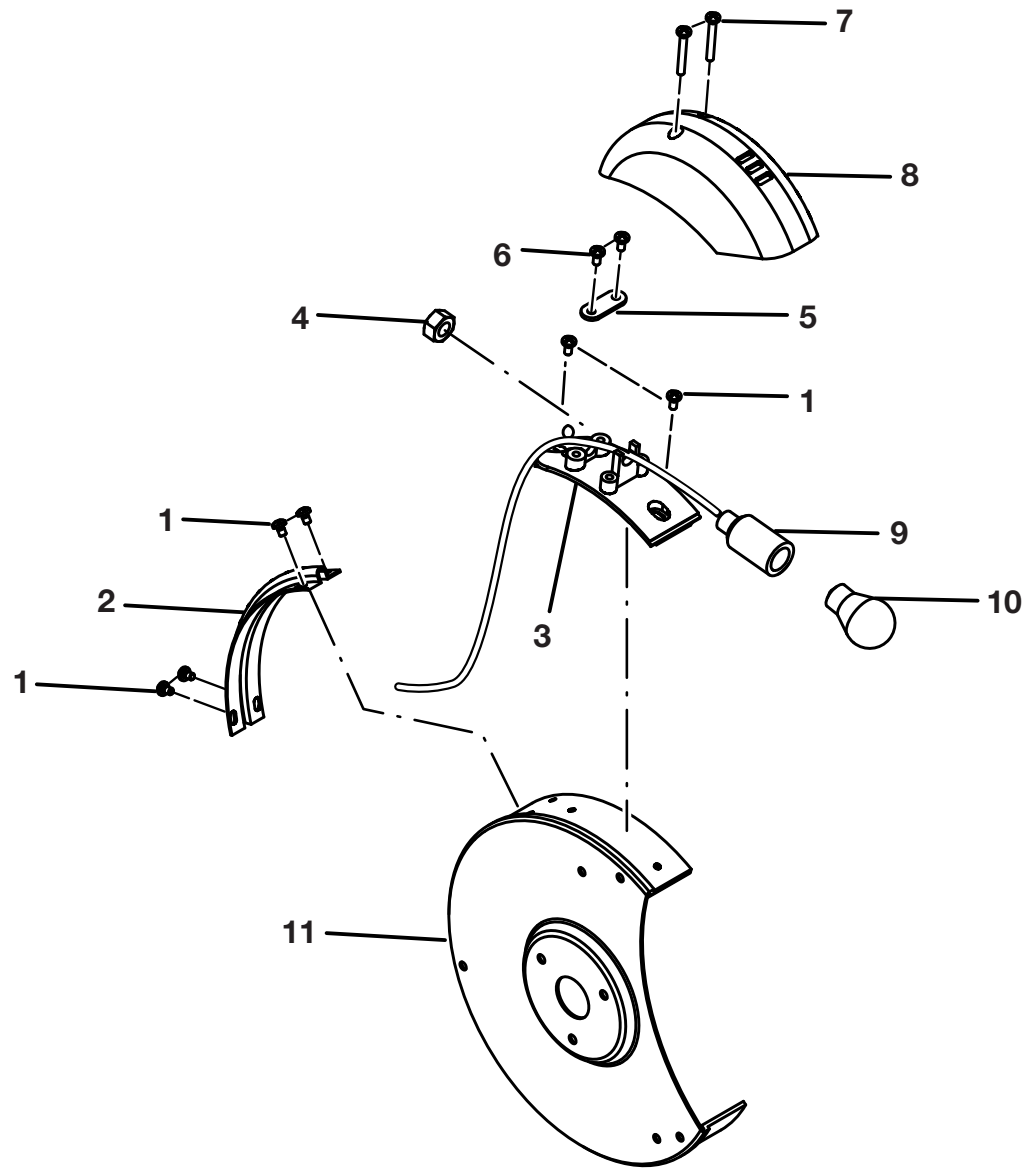

Figure D

RYOBI BENCH GRINDER – MODEL NUMBER BGH616

The model number will be found on a plate attached to the motor housing. Always mention the model number in all correspondence regarding your **BENCH GRINDER** or when ordering repair parts.

PARTS LIST (FIGURE D)

KEY NO.	PART NUMBER	DESCRIPTION	QTY
1	089150100024	* SCREW (M4 X 6 mm PAN HD.)	6
2	089150100018	LAMP CORD PRESSURE PLATE	1
3	089150100019	LAMP BASE	1
4	089150100020	LAMP SOCKET FIXING NUT	1
5	089150100021	LAMP CORD FIXING PLATE	1
6	601504	* SCREW (M4 X 10 mm PAN HD.)	2
7	089150100022	* SCREW (M4 X 30 mm PAN HD.)	2
8	089150100023	LAMP COVER	1
9	089150100025	LAMP SOCKET W/CORD	1
10	See Description	BULB (12V) No. 93 OR No. 1003 AVAILABLE AT LOCAL AUTO PARTS STORE	1
11	089150100028	RIGHT WHEEL GUARD.....	1

WARNING: Improper repair of a double insulated tool can result in damage to the double insulation system possibly causing electrical shock or electrocution. Any repairs requiring disassembly of your tool requires safety testing and should only be performed by a Ryobi Authorized Service Center. For the service center nearest you call 1-800-525-2579.

* STANDARD HARDWARE ITEM – MAY BE PURCHASED LOCALLY