

PLANER

AP-10

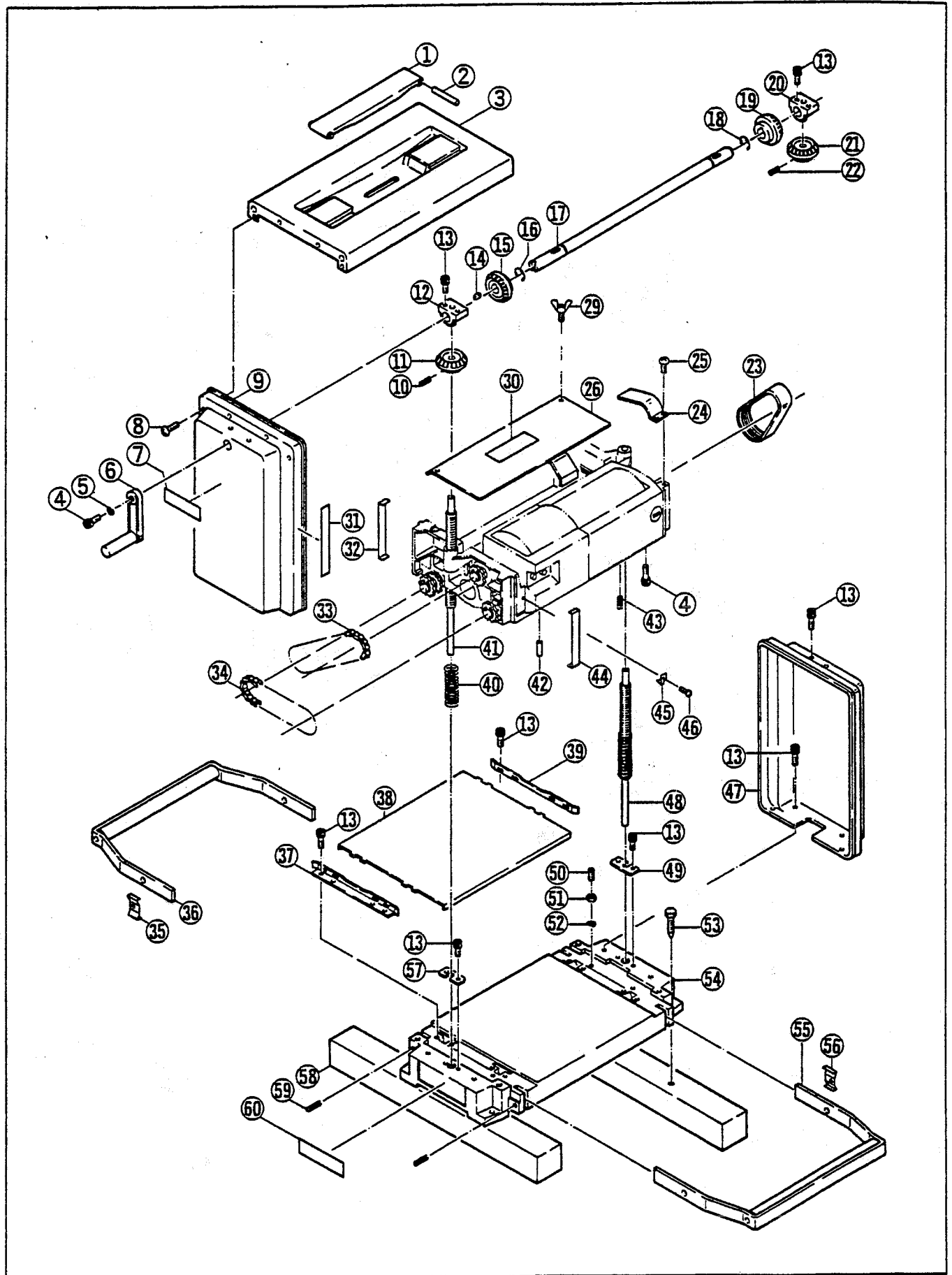

PLANER

AP-10

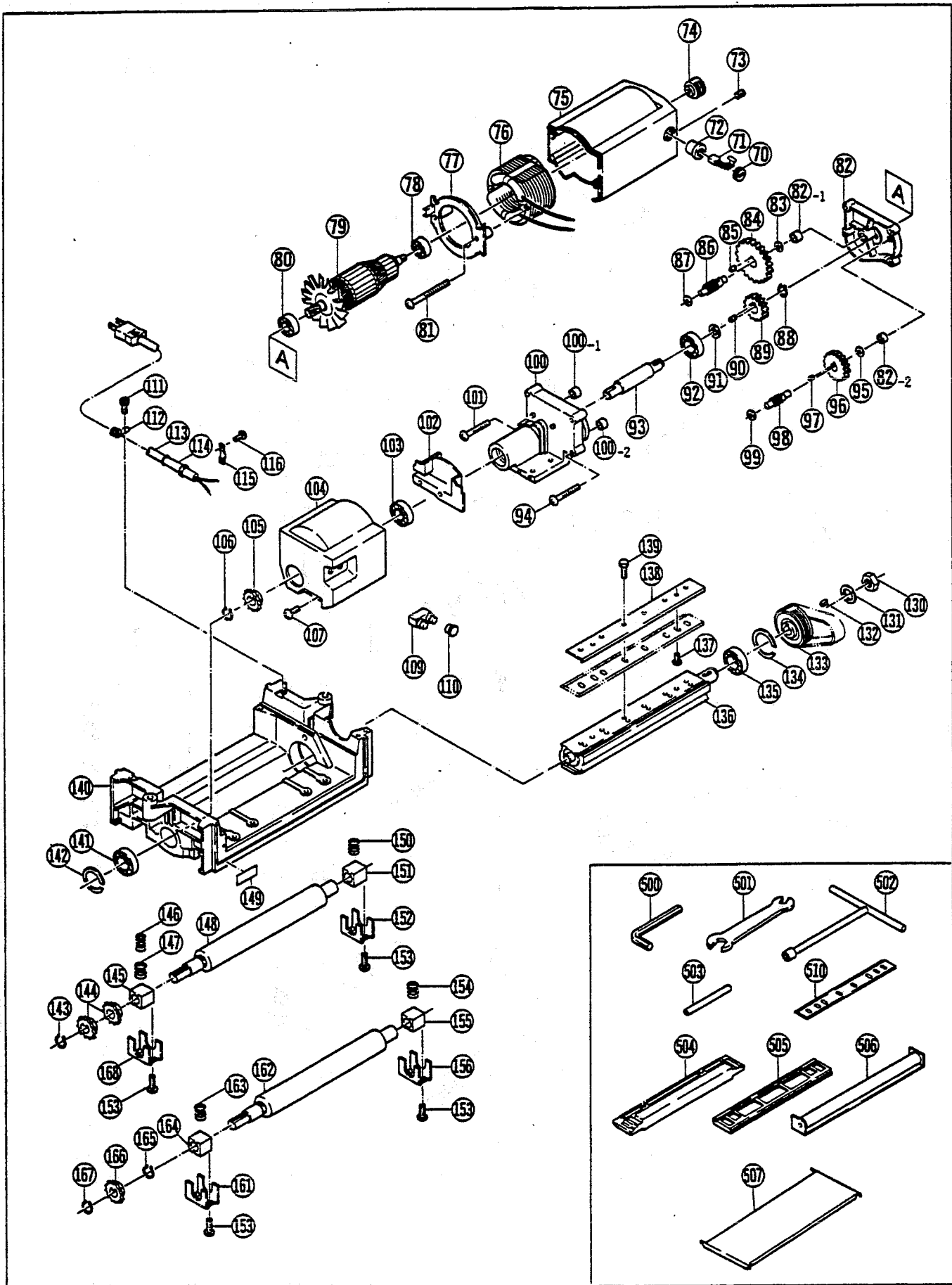

**PARTS LIST FOR AFTER SALES SERVICE
MODEL AP10**

REF	PART NO.	DESCRIPTION	QTY	REF	PART NO.	DESCRIPTION	QTY
1	6831097	AUX HANDLE	1	52	9550600	SPRING WASHER	4
2	6120156	SPRING PIN	2	53	6130737	WOODEN SCREW	4
3	6151418	COVER	1	54	6850269	BASE	1
4	9220620	HEX SOCKET HEAD BOLT M6X20	5	55	6080191	SUPPORTING ROLLER	1
5	9550600	SPRING WASHER M6	1	56	6180245	PLATE SPRING	1
6	6080198	CRANK HANDLE	1	57	6151451	SET PLATE	1
7	6920568	LABEL	1	58	6390113	STOCK	2
8	9040510	TAPPING SCREW (S) M5X10	8	59	9406020	SPRING PIN	4
9	6151430	COVER	1	60	6913581	NAME PLATE	1
10	9404025	SPRING PIN	1	70	6570107	BRUSH CAP	2
11	6200324	BEVEL GEAR	1	71	6540063	CARBON BRUSH SET	1
12	6330038	HOLDER	1	72	6570097	BRUSH HOLDER	2
13	9220610	HEX SOCKET HEAD BOLT M6X10	24	73	9280508	CLAMP SCREW M5X8	2
14	6100231	PARALLEL KEY	2	74	6860113	PULLEY	1
15	6200321	BEVEL GEAR	1	75	6801270	MOTOR HOUSING	1
16	9501200	RETAINING RING E-12	1	76	6501321	FIELD COIL	1
17	6100289	HANDLE SHAFT	1	77	6490279	FAN CASING	1
18	9501200	RETAINING RING E-12	1	78	9626201	BALL BEARING #6201LLB	1
19	6200321	BEVEL GEAR	1	79	6031575	ARMATURE	1
20	6330038	HOLDER	1	80	969235005	BALL BEARING #6200LLB	1
21	6200324	BEVEL GEAR	1	81	9060570	TAPPING SCREW (B) M5X70	2
22	9404025	SPRING PIN	1	82	6080194	INNER COVER	1
23	6860053	POLY V-BELT	1	82-1	6760007	OILLESS METAL	1
24	6880604	BELT COVER	1	82-2	6760046	OILLESS METAL	1
25	9040410	TAPPING SCREW (S) M4X10	2	83	6900284	THRUST WASHER	1
26	6151444	DUST FILTER	1	84	6200304	FINAL GEAR	1
29	9240512	WING BOLT M5X12	2	85	6100226	PARALLEL KEY	1
30	6920575	INDICATION LABEL	2	86	6200307	PINION GEAR	1
31	6920564	SCALE	1	87	6900284	THRUST WASHER	1
32	6151460	SPACER	2	88	9511500	RETAINING RING S-15	1
33	6860119	CHAIN	1	89	6200305	FINAL GEAR	1
34	6860119	CHAIN	1	90	6100226	PARALLEL KEY	1
35	6180245	PLATE SPRING	1	91	6900382	THRUST WASHER	1
36	6080191	SUPPORTING ROLLER	1	92	1750001	BALL BEARING #6202LLB	1
37	6151410	GUIDE PLATE	1	93	6110136	GEAR SHAFT	1
38	6151461	SLIDE PLATE	1	94	9060550	TAPPING SCREW (B) M5X50	3
39	6151410	GUIDE PLATE	1	95	6900103	WASHER	1
40	6180238	COMPRESSION SPRING	2	96	6200303	FINAL GEAR	1
41	6130503	FEED SCREW	1	97	6100084	PARALLEL KEY	1
42	6120160	PARALLEL PIN	1	98	6200306	PINION GEAR	1
43	6120161	PARALLEL PIN	1	99	6900103	WASHER	1
44	6151460	SPACER	2	100	6080199	GEAR CASE	1
45	6950101	SCALE ARROW	1	100-1	6760007	OILLESS METAL	1
46	9040410	TAPPING SCREW (S) M4X10	1	100-2	6760046	OILLESS METAL	1
47	6151426	COVER	1	101	9060560	TAPPING SCREW (B) M5X60	1
48	6130504	FEED SCREW	1	102	6880608	SWITCH COVER	1
49	6151451	SET PLATE	1	103	969235004	BALL BEARING #6002LB	1
50	9280620	CLAMP SCREW M6X20	4	104	6880613	SWITCH CASE	1
51	9300600	HEX NUT M6	4	105	6860086	CHAIN SPROCKET	1

PARTS LIST FOR AFTER SALES SERVICE MODEL AP10

106	9511500	RETAINING RING S-15	1	151	6760107	STRAIGHT METAL	1
107	9040412	TAPPING SCREW (S) M4X12	2	152	6151456	METAL COVER	1
109	6550337	PUSH BUTTON SWITCH	1	153	9040512	TAPPING SCREW (S) M5X12	8
110	6360210	SWITCH GUARD	2	154	6180240	COMPRESSION SPRING	1
111	9220610	HEX SOCKET HEAD BOLT M6X10	1	155	6760107	STRAIGHT METAL	1
112	6180243	CORD STAND	1	156	6151456	METAL COVER	1
113	6520234	CORD ASS'Y AWG#14X3X2	1	161	6151456	METAL COVER	1
114	6560052	CORD HOLDER	1	162	6860118	FEED ROLLER	1
115	6560067	CORD CLAMP	1	163	6180240	COMPRESSION SPRING	1
116	9060416	TAPPING SCREW (B) M4X16	2	164	6760107	STRAIGHT METAL	1
130	6130502	HEX NUT	1	165	9511500	RETAINING RING S-15	1
131	6900478	CONICAL SPRING WASHER	1	166	6860086	CHAIN SPROCKET	1
132	6100231	PARALLEL KEY	1	167	9511500	RETAINING RING S-15	1
133	6860112	PULLEY (L)	1	168	6151456	METAL COVER	1
134	9524000	RETAINING RING R-40	1	--	6530209	FASTEN CONNECTOR	1
135	971803001	BALL BEARING #6203LLB	1	--	6560026	TERMINAL	1
136	6940406	CUTTER BLOCK	1	--	6560019	TERMINAL	3
137	6131132	PHILLIPS PAN SCREW M5X8	4	--	9020408	PHILLIPS PAN SCREW M4X8	1
138	6940402	BLADE BINDER	2				
139	6130311	HEX HEAD BOLT M6X17	12				
140	6330048	ROLLER CASE	1			STANDARD ACCESSORIES	
141	1750001	BALL BEARING #6202LLB	1	500	6241153	HEX KEY WRENCH 3	1
142	9523500	RETAINING RING R-35	1	--	6241093	HEX KEY WRENCH 5	1
143	9511500	RETAINING RING S-15	1	501	6240113	OPEN-END WRENCH	1
144	6860086	CHAIN SPROCKET	2	502	6241533	"T" TYPE WRENCH 9	1
145	6760107	STRAIGHT METAL	1	503	6120158	LOCK PIN	1
146	6180241	COMPRESSION SPRING	1	504	6072553	SHARPENING HOLDER	1
147	6180240	COMPRESSION SPRING	1	505	6072883	BLADE ADJUSTMENT GAUGE	1
148	6860118	FEED ROLLER	1	506	6072443	AUX. ROLLER	2
149	6920558	"RYOBI" MARK	1	507	6153602	GUARD PLATE	1
150	6180240	COMPRESSION SPRING	1	510	6660423	10" PLANER BLADE	1

SERVICE NOTES:

