



# OPERATOR'S MANUAL

## DADO THROAT PLATE

A31TS01

(FOR USE WITH THE BTS10, BTS11 TABLE SAWS)

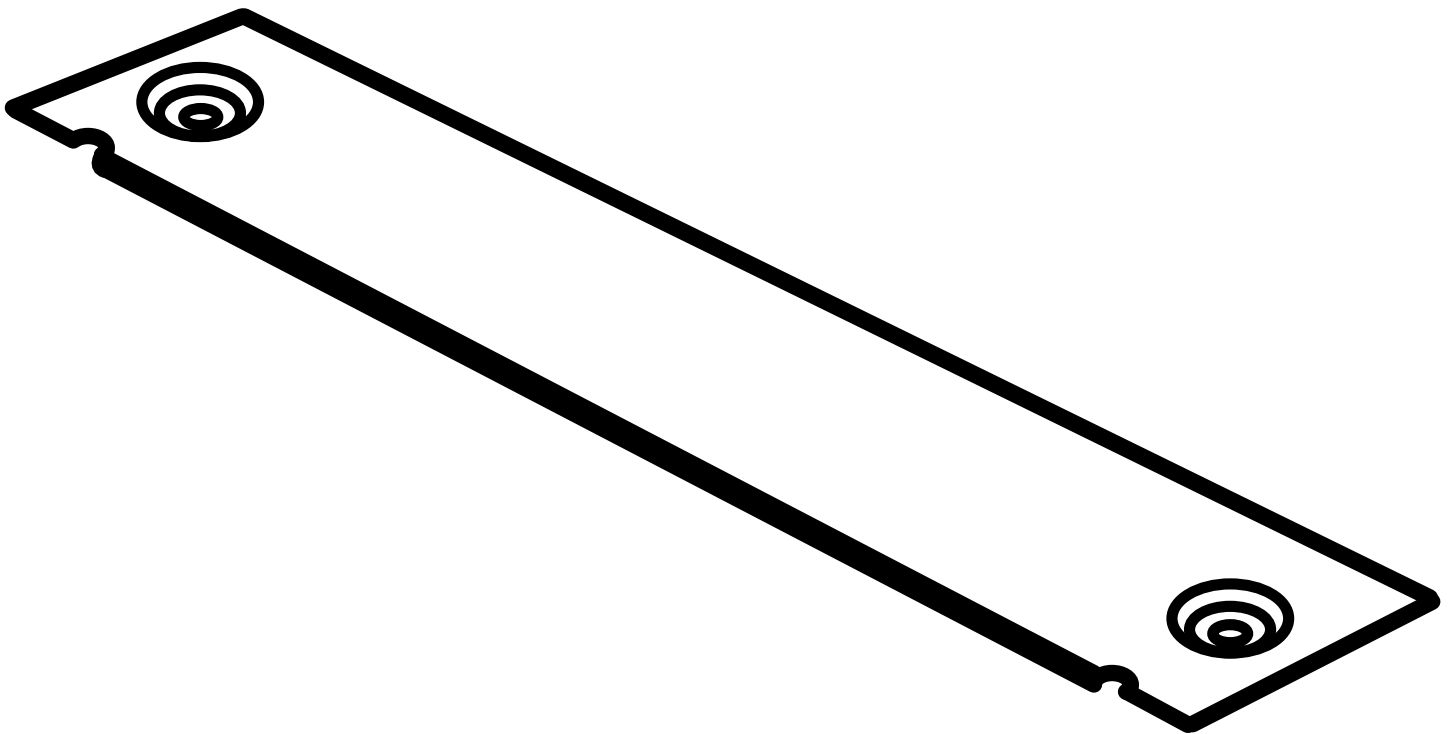

Your Dado Throat Plate has been engineered and manufactured to Ryobi's high standards for dependability, ease of operation, and operator safety.

**⚠ WARNING:** To reduce the risk of injury, the user must read and understand the operator's manual.

Thank you for buying a Ryobi tool.

**SAVE THIS MANUAL FOR FUTURE REFERENCE**

# TABLE OF CONTENTS

■ Introduction.....	2
■ General Safety Rules .....	2
■ Symbols .....	2-3
■ Unpacking.....	4
■ Assembly .....	5
■ Operation .....	5
■ Parts Ordering / Service .....	6

## INTRODUCTION

This tool has many features for making its use more pleasant and enjoyable. Safety, performance, and dependability have been given top priority in the design of this product making it easy to maintain and operate.

## GENERAL SAFETY RULES



**Safe operation of this accessory requires that you read and understand this operator's manual, the operator's manual for the table saw and all labels affixed to the tool.**

### READ ALL INSTRUCTIONS

- **KNOW YOUR ACCESSORY.** Read the operator's manual carefully. Learn the product's applications and limitations as well as the specific potential hazards related to this product.
- **KEEP THE WORK AREA CLEAN.** Cluttered work areas and work benches invite accidents. **DO NOT** leave tools or pieces of wood on the saw while operating.
- **ALWAYS WEAR SAFETY GLASSES WITH SIDE SHIELDS.** Everyday eyeglasses have only impact-resistant lenses; they are **NOT** safety glasses.
- **DO NOT USE THIS PRODUCT WITH OTHER EQUIPMENT** or for other purposes.
- **ALWAYS DISCONNECT THE SAW FROM THE POWER SUPPLY BEFORE ASSEMBLING THIS KIT.** Make sure the switch is off when reconnecting the saw to a power supply.
- **BEFORE MAKING A CUT, BE SURE ALL ADJUSTMENTS ARE SECURE.**
- **SAVE THESE INSTRUCTIONS.** Refer to them frequently and use them to instruct other users. If you loan someone this product, also loan these instructions.

## SYMBOLS

The following signal words and meanings are intended to explain the levels of risk associated with this product.

SYMBOL	SIGNAL	MEANING
	<b>DANGER:</b>	Indicates an imminently hazardous situation, which, if not avoided, will result in death or serious injury.
	<b>WARNING:</b>	Indicates a potentially hazardous situation, which, if not avoided, could result in death or serious injury.
	<b>CAUTION:</b>	Indicates a potentially hazardous situation, which, if not avoided, may result in minor or moderate injury.
	<b>CAUTION:</b>	(Without Safety Alert Symbol) Indicates a situation that may result in property damage.

# UNPACKING

## INFORMATION

- Remove the loose parts from the box.
- Inspect the dado throat plate carefully to make sure no breakage or damage occurred during shipping.
- If the dado throat plate is damaged, please call 1-800-525-2579 for assistance.

## LOOSE PARTS LIST

- Dado throat plate
- 10-24 x 1/2 in. screws (2)

## TOOLS NEEDED

Phillips head screwdriver

### **⚠ WARNING:**

If any parts are missing, replace the missing parts before assembling the kit. Failure to do so could result in serious personal injury.

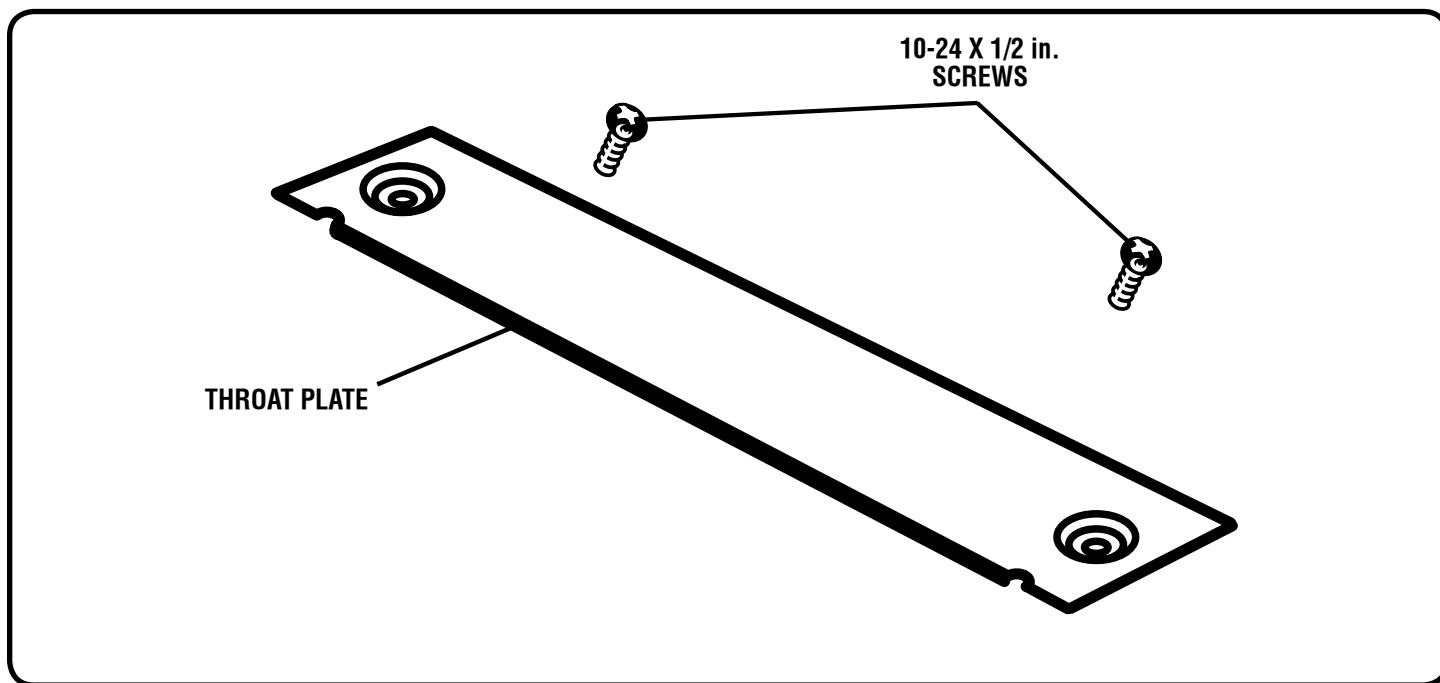

# ASSEMBLY

## INSTALLING A DADO INSERT

See Figures 1-2.

- Unplug the saw.

### **⚠ WARNING:**

Do not allow familiarity with tools to make you careless. Remember that a careless fraction of a second is sufficient to inflict severe injury.

### **⚠ WARNING:**

Failure to turn the saw off, remove the switch key, and unplug the saw could result in accidental starting causing possible serious personal injury.

## BTS10 TABLE SAW PRIOR TO DADO INSERT INSTALLATION

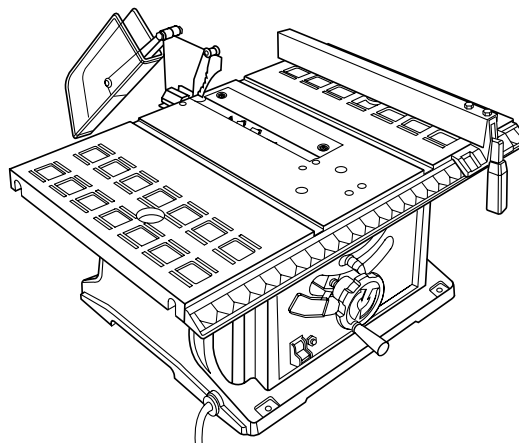

Fig. 1

# ASSEMBLY

- Lower the blade below the table surface.
- Loosen the screws and remove the throat plate.
- Remove the blade and blade guard assembly following instructions in the table saw Operator's Manual.
- Included with the dado set are installation instructions. Follow these instructions to install the dado set.  
**NOTE:** When using 3/8 in. width dado set use outer flange and nut.  
**NOTE:** When using 7/16 in. width dado set use nut only.
- Place dado insert on the table saw as shown in figure 1.
- Securely tighten using screws provided.

## **⚠ WARNING:**

Never stand directly in line with the blade or allow hands to come closer than 3 in. to the blade. Do not reach over or across the blade. Failure to heed this warning can result in serious personal injury.

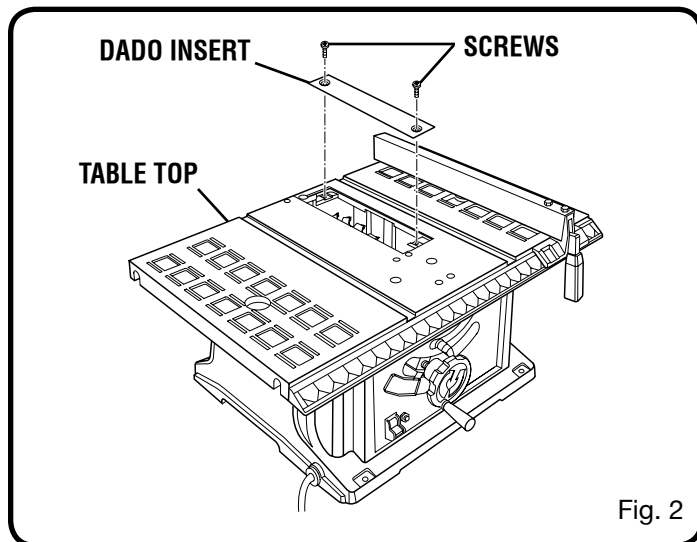

# OPERATION

## APPLICATIONS

You may use this tool for the purposes listed below:

- For cutting up to 7/16 in. maximum width dados on BTS10 and BTS11 Ryobi table saws.

## **⚠ WARNING:**

Never install a dado set to cut a larger groove than 7/16 in. in width. Installing a wider dado set could result in insufficient thread engagement of the arbor nut. Never use any blade or dado set with less than full engagement of the nut of the threaded arbor shaft. Insufficient thread engagement could result in the blade or dado loosening on the arbor shaft and could result in serious personal injury.

## USING A DADO INSERT

- Make sure the wood is not touching the blade. Plug in the saw, insert the switch key, and turn the saw on. Let the saw build up to full speed before feeding the workpiece into the blade. Always use push sticks or push blocks with dado cuts.

## **⚠ WARNING:**

Always use push sticks or push blocks when making non-through cuts to avoid the risk of serious injury. Never feed wood with your hands.

- Follow all dado instructions.
- When the work is complete, turn the saw off, remove the switch key, and unplug the saw.
- Lower the blade below the table surface.

## **⚠ WARNING:**

Lower the blade to prevent possible injury.

- Remove the dado insert and dado set.
- Reinstall the blade, blade guard assembly, and throat plate following instructions in the Operator's Manual.

## **⚠ WARNING:**

To reduce the risk of injury and before plugging the saw back in, make sure the blade guard is installed and working properly.



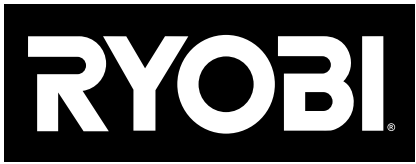

# OPERATOR'S MANUAL

## DADO THROAT PLATE

A31TS01

(FOR USE WITH THE BTS10, BTS11 TABLE SAWS)

### WARRANTY

Ryobi warrants its accessories for a period of 90 days from the date of purchase. Batteries and chargers are warranted for a period of two years from the date of purchase.

### PARTS AND SERVICE

For parts or service, contact your nearest Ryobi authorized service center. Be sure to provide all relevant information when you call or visit. For the location of the authorized service center nearest you, please call 1-800-525-2579 or visit us online at [www.ryobitools.com](http://www.ryobitools.com). When ordering parts, always give the model number:

MODEL NUMBER \_\_\_\_\_

### RYOBI TECHNOLOGIES INC.

1428 Pearman Dairy Road Anderson SC 29625  
Post Office Box 1207 Anderson SC 29622-1207  
Phone 1-800-525-2579  
[www.ryobitools.com](http://www.ryobitools.com)